



# 24-INCH REFRIGERATOR COLUMN, PANEL-READY

DRR24980LAP | DRR24980RAP



## PRODUCT FEATURES

- Full height door with true flush cabinet integration without exposed venting grille
- SteelCool™ Stainless Steel Interior illuminated by 3DLighting™
- Push-To-Open™ Door Assist opens the door upon a slight push for a luxuriously convenient experience
- Internal Water Dispenser for easy access to clean, filtered water
- iQ RemoteView™ Cameras (Wi-Fi) enables users to check what's in your fridge from your phone

## TEMPERATURE RANGES

REFRIGERATOR	34°F (1°C) TO 44°F (7°C)
REFRIGERATOR - POWER COOL	34°F (1°C)
FRESHZONE™ DRAWER	37°F (3°C) / 33°F (-1°C)/29°F (-1°C)

## DIMENSIONS & WEIGHT

APPLIANCE DIMENSIONS (W X H X D) (IN.)	23 3/4" X 83 3/8" X 25"
REQUIRED CUTOUT SIZE (W X H X D) (IN.)	24" X 84" X 25"
NET WEIGHT (LBS)	377

## GENERAL PROPERTIES

PANEL READY	YES
DOOR SWING	LAP-LEFT, RAP-RIGHT
PUSH-TO-OPEN™ DOOR ASSIST	YES
INTERNAL WATER DISPENSER	YES
IQ REMOTEVIEW™ CAMERA	YES (2 EA)
DEODORIZING FILTER	YES
LIGHTING	3DLIGHTING™
INTERIOR MATERIAL	STEELCOOL™ STAINLESS STEEL INTERIOR
FULL WIDTH SHELVES	4 EA
SHELF MATERIAL	TEMPERED, METAL TRIM, SPILL-PROOF
FULL EXTENSION DRAWERS AT 90° DOOR OPENING ANGLE	YES
FRESHZONE™ DRAWER	YES - CHEESE (37°F) / COLD DRINKS (33°F) / MEAT (29°F)
CRISPER DRAWERS	2 EA
DOOR BINS	4 EA
DOOR OPEN ALARM	YES
SPECIAL MODES	SABBATH MODE

## CAPACITY

TOTAL UNIT GROSS CAPACITY (CU.FT.) - AHAM	13.7 CU. FT.
REFRIGERATOR GROSS CAPACITY (CU.FT.)	13.7 CU. FT.

## PERFORMANCE

DEDICATED EVAPORATOR & COMPRESSOR SYSTEM	YES
POWER COOL	YES
PRECISE COOLING	YES

## EFFICIENCY

ENERGY STAR QUALIFIED	YES
ANNUAL ENERGY CONSUMPTION	260 KWH/YEAR

## TECHNICAL DETAILS

CURRENT (A)	15
VOLTS (V)	115
FREQUENCY (HZ)	60
POWER CORD LENGTH (IN.)	78 3/4"
PLUG TYPE	120 V, 3 PRONG

## WARRANTY

LIMITED, ENTIRE APPLIANCE, PARTS AND LABOR ON ANY PART OF THE REFRIGERATOR	2 YEAR
LIMITED WARRANTY FOR SEALED REFRIGERATION SYSTEM; PARTS AND LABOR	3 <sup>RD</sup> TO 6 <sup>TH</sup> YEAR
LIMITED WARRANTY FOR SEALED REFRIGERATION SYSTEM; PARTS ONLY	7 <sup>TH</sup> TO 12 <sup>TH</sup> YEAR
LIMITED WARRANTY FOR COMPRESSOR; PARTS ONLY	13 <sup>TH</sup> TO 15 <sup>TH</sup> YEAR

### APPLIANCE DIMENSIONS

A (WIDTH)	23 3/4" (603 MM)
B (WITH PANEL)	25" (635 MM)
B1 (WITHOUT PANEL)	23 13/16" (605MM)
C (HEIGHT)	83 3/8" (2118MM)
D	23 5/8" (600 MM)
D1 (WITH PANEL)	24 7/8" (631 MM)
D2 (WITH MODERNIST HANDLE)	26 3/4" (680 MM)
D3 (WITH PRO HANDLE)	27 3/8" (696 MM)
E	50 3/4" (1289 MM)
F	13 11/16" (348 MM)
G	49 11/16" (1261 MM)

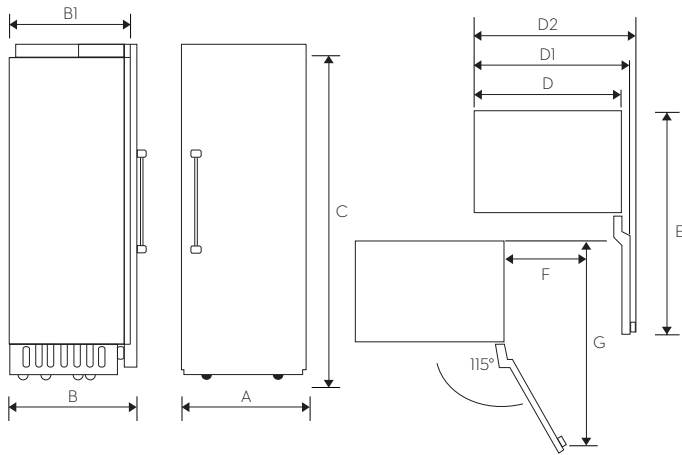

### INSTALLATION CUTOUT DIMENSIONS

A (WIDTH)	24" (762MM)
B (DEPTH)	25" (635MM)
C (HEIGHT)	84" (2,134MM)
D	14" (508MM)
E	80" (2,032MM)

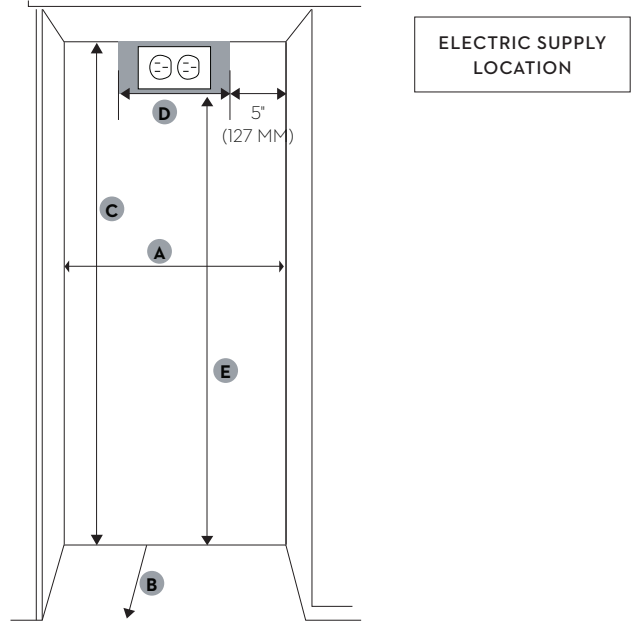

### CUSTOM PANEL DIMENSIONS

A-1 (WIDTH)	23 3/4" (756MM)
A-2 (HEIGHT)	79 7/8" (2029MM)
A-3 (DEPTH)	3/4" (19MM)
MAX WEIGHT	110.0 LBS. (50KG)

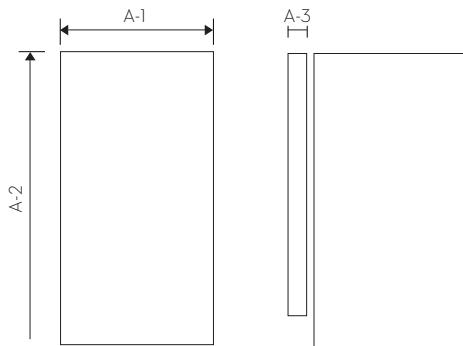

### WATER SUPPLY CONNECTION REQUIREMENTS

A	5 1/2" (140 MM)
---	-----------------

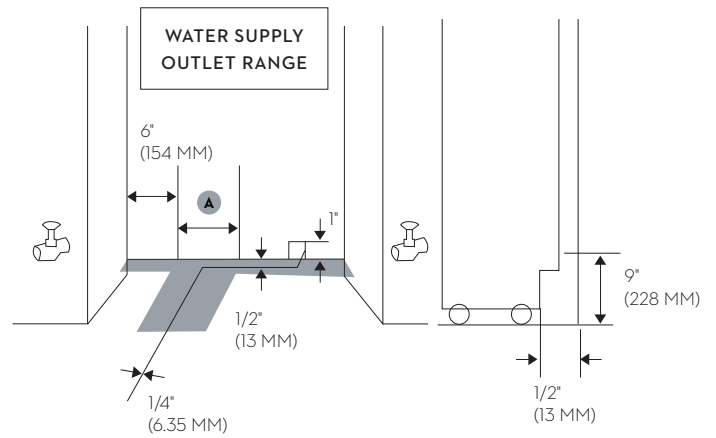

### ACCESSORIES

MODERNIST GRAPHITE STAINLESS STEEL - 24" PANEL KIT	RAC24AMLHMS (LEFT HINGE), RAC24AMRHMS (RIGHT HINGE)
MODERNIST SILVER STAINLESS STEEL - 24" PANEL KIT	RAC24AMLHRSR (LEFT HINGE), RAC24AMRHRSR (RIGHT HINGE)
HERITAGE PRO SILVER STAINLESS STEEL - 24" PANEL KIT	RAC24AHLHRSR (LEFT HINGE), RAC24AHRHRSR (RIGHT HINGE)
MODERNIST GRAPHITE STAINLESS STEEL - 24" KICK PLATE	RAC24TKBBMS
MODERNIST SILVER STAINLESS STEEL - 24" KICK PLATE	RAC24TKBBSR
GRAPHITE STAINLESS STEEL - MODERNIST HANDLE	RACOOMHAAMS
SILVER STAINLESS STEEL - MODERNIST HANDLE	RACOOMHAASR
SILVER STAINLESS STEEL - HERITAGE PRO HANDLE	RACOOPHAASR
SILVER STAINLESS STEEL - EPICURE HANDLE	ADRRZHIE
PAIR INSTALLATION KIT	RACOOCPAAAA
WATER FILTER	RACOOWFAAAA
DEODORIZING FILTER	RACOODFAAAA

**DRZ18980LAP**  
**18-INCH FREEZER COLUMN, LEFT-HINGE**  
 MODERNIST, PANEL-READY

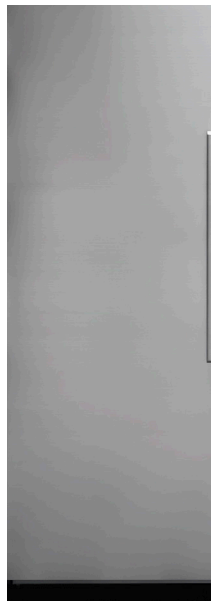

**FEATURES & BENEFITS**

- Full height door with true flush cabinet integration without exposed venting grille
- SteelCool™ Stainless Steel Interior Illuminated by 3DLighting™
- Push-To-Open™ Door Assist opens the door upon a slight push for a luxuriously convenient experience

**TEMPERATURE RANGES**

Freezer	5°F (-15°C) to -8°F (-23°C)
Freezer - Power Freeze	-8°F (-23°C)

**ACCESSORIES (OPTIONAL)**

Graphite Stainless Steel - 18" Panel (Left Hinge)	RAC18DPLHMS
Graphite Stainless Steel - 18" Kick Plate	RAC18TKBBMS
Graphite Stainless Steel - Modernist Handle	RAC00MHAAMS
Silver Stainless Steel - 18" Panel (Left Hinge)	RAC18DPLHSR
Silver Stainless Steel - 18" Kick Plate	RAC18TKBBBSR
Silver Stainless Steel - Modernist Handle	RAC00MHAASR
Silver Stainless Steel - Dacor Pro Handle	RAC00PHAASR
Pair Installation Kit	RAC00CPAAAA
Water Filter	RAC00WFAAAA
Deodorizing Filter	RAC00DFAAAA

**GENERAL PROPERTIES**

Panel Ready	Yes
Door Swing	Left
Push-To-Open™ Door Assist	Yes
Icemaker	Standard Icemaker
Lighting	3DLighting™
Interior Material	SteelCool™ Stainless Steel Interior
Full Width Shelves	3 ea
Shelf Material	Tempered, Metal Trim, Spill-Proof
Full Extension Drawers at 90° Door Opening Angle	Yes
Hidden Box with Flip-up Cover	No
Freezer Drawer	2 ea
Door Bins	4 ea
Door Open Alarm	Yes
Special Modes	Sabbath Mode

**CAPACITY**

Total Unit Gross Capacity (cu. ft.) - AHAM	9.4 cu. ft.
Freezer Gross Capacity (cu. ft.)	9.4 cu. ft.

**PERFORMANCE**

Dedicated Evaporator & Compressor System	Yes
Power Freeze	Yes
Defrost Process	Frost-Free
Temperature Fluctuation	±0.36°F* (±0.2°C*)

**TECHNICAL DETAILS**

Current (A)	3
Volts (V)	115
Frequency (Hz)	60
Power Cord Length (in.)	78 3/4"
Plug Type	120V, 3 Prong

**DIMENSIONS**

Appliance dimensions (H x W x D) (in.)	83 3/8" x 17 5/8" x 23 13/16"
Required Cutout Size (H x W x D) (in.)	84" x 18" x 25"

**EFFICIENCY**

ENERGY STAR Qualified	Yes
Annual Energy Consumption	465 kWh

**WARRANTY**

Limited, Entire Appliance, Parts and Labor on Any Part of the Freezer	2 Year
Limited Warranty for Sealed Freezer System; Parts and Labor	3rd to 6th Year
Limited Warranty for Sealed Freezer System; Parts Only	7th to 12th Year

**DRZ18980LAP**  
**18-INCH FREEZER COLUMN, LEFT-HINGE**  
 MODERNIST, PANEL-READY



**APPLIANCE DIMENSIONS**

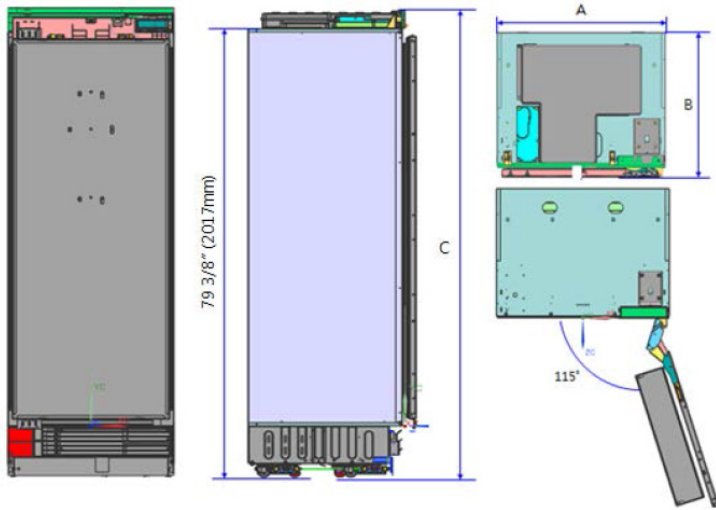

	18"
A (Width)	17 5/8" (447mm)
B (Depth)	23 13/16" (605mm)
C (Height)	83 3/8" (2118mm)

**INSTALLATION CUTOUT DIMENSIONS**

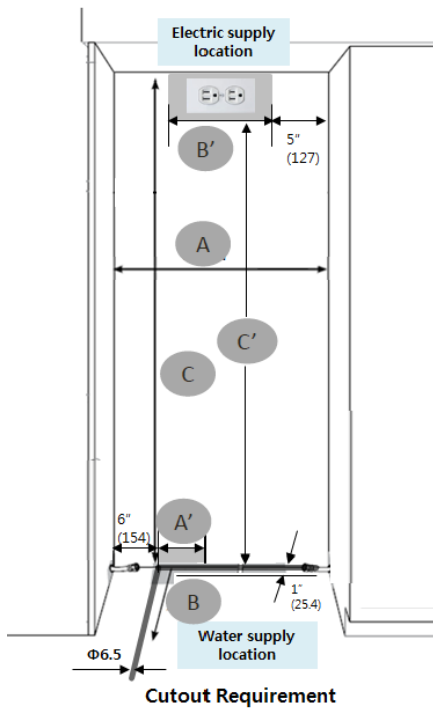

	18"
A (Width)	18" (457mm)
B (Depth)	25" (635mm)
C (Height)	84" (2134mm)
A'	3" (140mm)
B'	8" (356mm)
C'	80" (2032mm)

**CUSTOM PANEL DIMENSIONS**

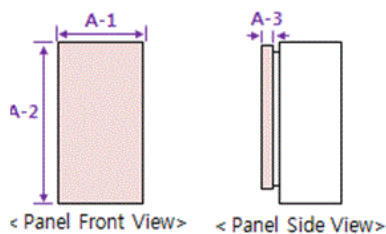

	18"
A-1 (Width)	17 3/4" (603mm)
A-2 (Height)	79 7/8" (2029mm)
A-3 (Depth)	3/4" (19mm)
Max Weight	132.0 lbs. (60kg)

**DRZ18980RAP**  
**18-INCH FREEZER COLUMN, RIGHT-HINGE**  
 MODERNIST, PANEL-READY



GENERAL PROPERTIES	
Panel Ready	Yes
Door Swing	Right
Push-To-Open™ Door Assist	Yes
Icemaker	Standard Icemaker
Lighting	3DLighting™
Interior Material	SteelCool™ Stainless Steel Interior
Full Width Shelves	3 ea
Shelf Material	Tempered, Metal Trim, Spill-Proof
Full Extension Drawers at 90° Door Opening Angle	Yes
Hidden Box with Flip-up Cover	No
Freezer Drawer	2 ea
Door Bins	4 ea
Door Open Alarm	Yes
Special Modes	Sabbath Mode
CAPACITY	
Total Unit Gross Capacity (cu. ft.) - AHAM	9.4 cu. ft.
Freezer Gross Capacity (cu. ft.)	9.4 cu. ft.
PERFORMANCE	
Dedicated Evaporator & Compressor System	Yes
Power Freeze	Yes
Defrost Process	Frost-Free
Temperature Fluctuation	±0.36°F* (±0.2°C*)
TECHNICAL DETAILS	
Current (A)	3
Volts (V)	115
Frequency (Hz)	60
Power Cord Length (in.)	78 3/4"
Plug Type	120V, 3 Prong
DIMENSIONS	
Appliance dimensions (H x W x D) (in.)	83 3/8" x 17 5/8" x 23 13/16"
Required Cutout Size (H x W x D) (in.)	84" x 18" x 25"
EFFICIENCY	
ENERGY STAR Qualified	Yes
Annual Energy Consumption	465 kWh
WARRANTY	
Limited, Entire Appliance, Parts and Labor on Any Part of the Freezer	2 Year
Limited Warranty for Sealed Freezer System; Parts and Labor	3rd to 6th Year
Limited Warranty for Sealed Freezer System; Parts Only	7th to 12th Year

**FEATURES & BENEFITS**

- Full height door with true flush cabinet integration without exposed venting grille
- SteelCool™ Stainless Steel Interior Illuminated by 3DLighting™
- Push-To-Open™ Door Assist opens the door upon a slight push for a luxuriously convenient experience

**TEMPERATURE RANGES**

Freezer	5°F (-15°C) to -8°F (-23°C)
Freezer - Power Freeze	-8°F (-23°C)

**ACCESSORIES (OPTIONAL)**

Graphite Stainless Steel - 18" Panel (Right Hinge)	RAC18DPLHMS
Graphite Stainless Steel - 18" Kick Plate	RAC18TKBBMS
Graphite Stainless Steel - Modernist Handle	RAC00MHAAMS
Silver Stainless Steel - 18" Panel (Right Hinge)	RAC18DPLHSR
Silver Stainless Steel - 18" Kick Plate	RAC18TKBBBSR
Silver Stainless Steel - Modernist Handle	RAC00MHAASR
Silver Stainless Steel - Dacor Pro Handle	RAC00PHAASR
Pair Installation Kit	RAC00CPAAAA
Water Filter	RAC00WFAAAA
Deodorizing Filter	RAC00DFAAAA

**DRZ18980RAP**  
**18-INCH FREEZER COLUMN, RIGHT-HINGE**  
 MODERNIST, PANEL-READY



**APPLIANCE DIMENSIONS**

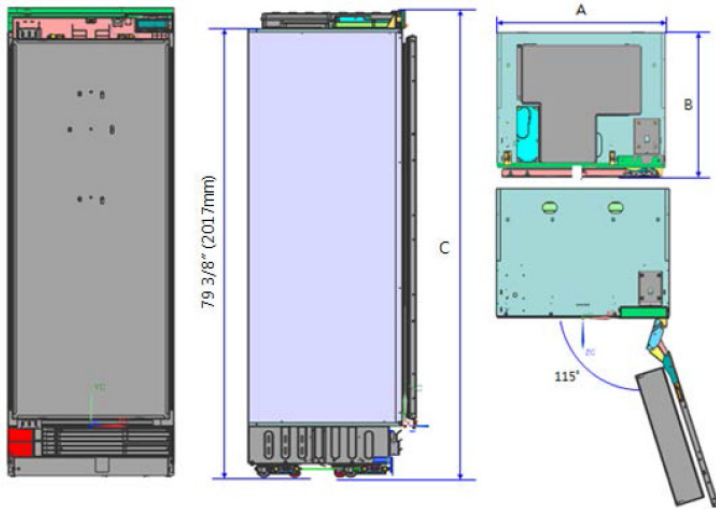

	18"
A (Width)	17 5/8" (447mm)
B (Depth)	23 13/16" (605mm)
C (Height)	83 3/8" (2118mm)

**INSTALLATION CUTOUT DIMENSIONS**

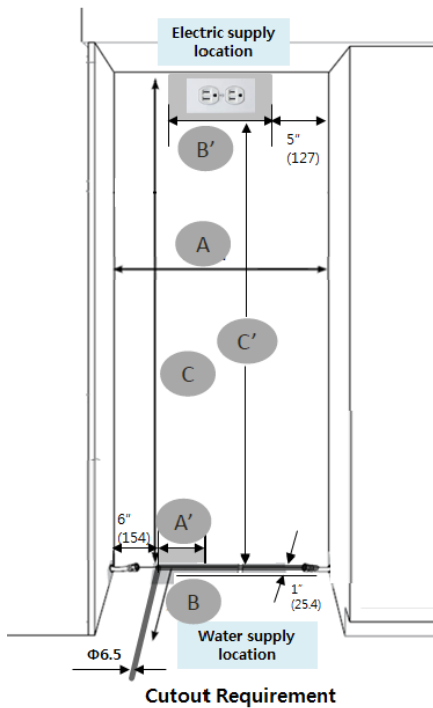

	18"
A (Width)	18" (457mm)
B (Depth)	25" (635mm)
C (Height)	84" (2134mm)
A'	3" (140mm)
B'	8" (356mm)
C'	80" (2032mm)

**CUSTOM PANEL DIMENSIONS**

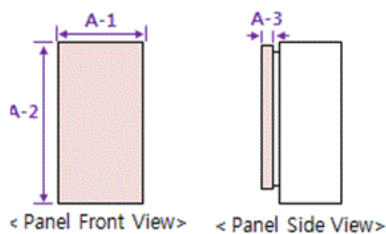

	18"
A-1 (Width)	17 3/4" (603mm)
A-2 (Height)	79 7/8" (2029mm)
A-3 (Depth)	3/4" (19mm)
Max Weight	132.0 lbs. (60kg)