



Cabinet Blower

PLANNING GUIDE

Total Connected Load	Blower Rating* (CFM)	Approx. Ship Weight
4 Amps. @ 120Vac, 60 Hz	600 Nom.; 585.6 Actual	34 lbs
* At zero inches static pressure. Performance varies based on duct system configuration.		

WARNING

- Observe all local ordinances during planning and installation. Contact your local building department for details.
- This appliance must be installed in accordance with the accompanying installation instructions.

NOTE:

See downdraft Planning planning guide for approved applications.

CABP3 Top

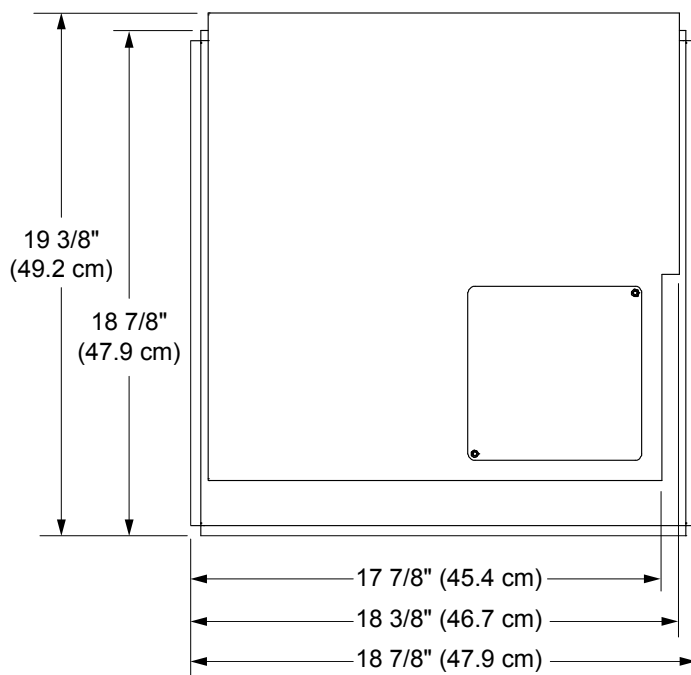

CABP3 Electrical-Location (side)

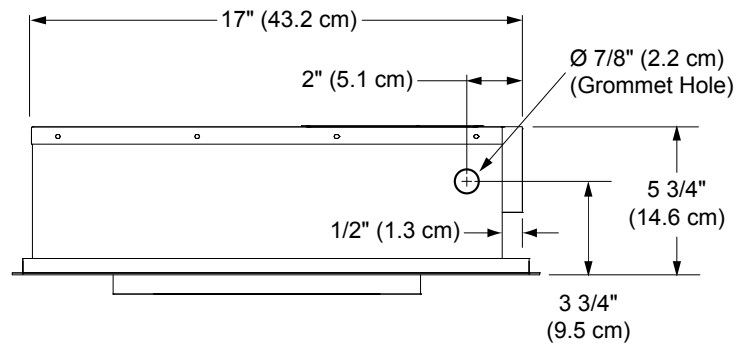

CABP3 Duct-Location (side)

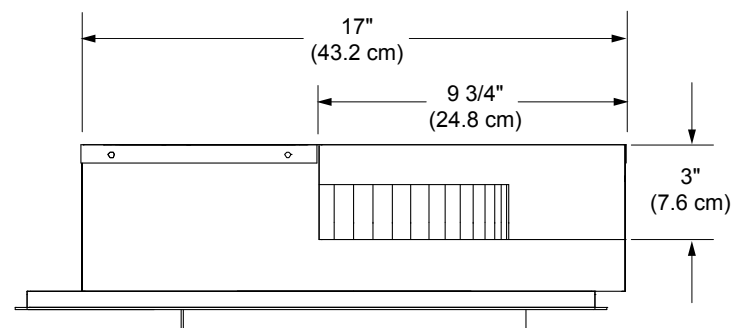

CABP3

