



30-INCH 5 BURNER GAS COOKTOP

HCT305GS | HERITAGE COLLECTION



AVAILABLE MODELS

- HCT305GS/NG/H 30" Heritage Gas Cooktop 5 Burner SS Natural Gas High Alt.
- HCT305GS/NG 30" Heritage Gas Cooktop 5 Burner SS Natural Gas
- HCT305GS/LP/H 30" Heritage Gas Cooktop 5 Burner SS Liquid Propane High Alt.
- HCT305GS/LP 30" Heritage Gas Cooktop 5 Burner SS Liquid Propane

FEATURES & BENEFITS

- Illumina™ Indicator Lights for both style and peace of mind in the kitchen.
- SimmerSear™ Burner provides up to 18,000 BTU's and achieves ultralow temperatures for simmering and melting without any scorching.
- PermaClean™ Finish is an exclusive scratch-resistant, bead-blasted surface that retains a permanently beautiful finish.
- One-Piece Spill Basin ensures easy clean-up.
- Continuous Platform Grates for the optimum cooking surface for larger pots:
 - 2 - 8 1/2" Wide Continuous Platform Grates
 - 1 - 10 1/2" Wide Continuous Platform Grate
- Downdraft compatible for use in island configurations (MRV3015S)
- Smart Flame™ Technology for heat management to preserve the finish and life of the grates.
- Die Cast Knobs for durability and style.
- 4" Chassis Height for over-the-oven configurations.
- 5 Sealed (brass) with porcelain caps
 - Center, 18,000 (BTU) Brass Dual Burner (SimmerSear)
 - Left Front, 9,000 (BTU) Brass Standard
 - Left Rear, 12,000 (BTU) Brass Standard
 - Right Front, 9,000 (BTU) Brass Standard
 - Right Rear, 12,000 (BTU) Brass Standard

CONTROL FEATURES - LED BLUE

NUMBER OF KNOBS	5 KNOBS
PERMA-FLAME™ (AUTO RE-IGNITION)	YES
ERGONOMIC, ANGLED CONTROLS	YES

TECHNICAL DETAILS

CIRCUIT BREAKER (A)	15
VOLTS (V)	120
FREQUENCY (HZ)	60
ENERGY SOURCE	GAS

DIMENSIONS & WEIGHT

APPLIANCE DIMENSIONS (H X W X D) (IN.)	4" X 30" X 21"
REQUIRED CUTOUT SIZE (W X D) (IN.)	27 5/8" X 19 5/8"

ACCESSORIES (OPTIONAL)

WOK RING	AWR4
REMOVABLE NON-STICK GRIDDLE-GRILL	AGDCT12

**Warranty: Limited, parts and labor for one year

APPLIANCE DIMENSIONS

30"

A (TOP FRAME WIDTH) 30" (76.2 CM)

B (CHASSIS WIDTH) 19 9/32" (49.0 CM)

C (CHASSIS HEIGHT) 4" (10.2 CM)

Product tolerances $\pm 1/16"$ (± 1.6 mm) unless otherwise noted.

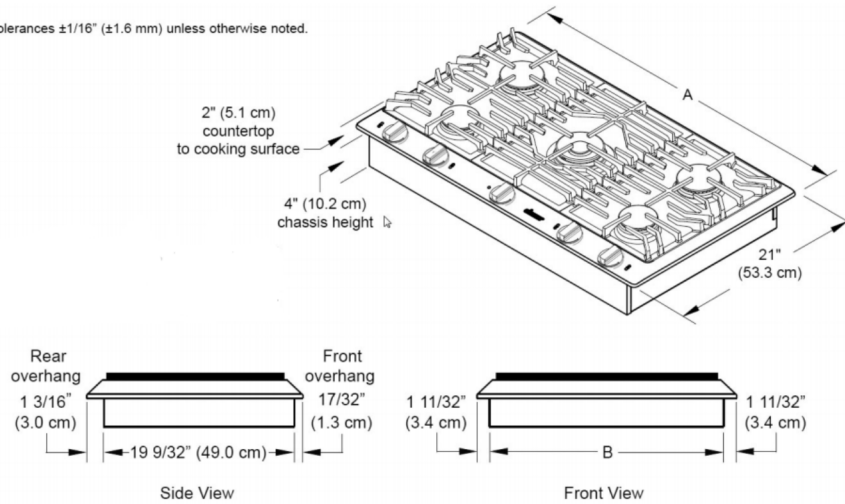

CABINET CUT-OUT DIMENSIONS

COOKTOP MODEL	C	D	E	F
HCT305GS WITH NO DOWNDRAFT VENT	3 1/4" (8.3 CM)	19 5/8" (49.9 CM)	27 5/8" (70.2 CM)	6 7/8" (17.5 CM)
HCT305GS WITH MRV3015S	3/8" (1.0 CM)	22 3/4" (57.8 CM)		

