

CRYSTORAMA

LIGHTING THE WAY FOR SIXTY YEARS

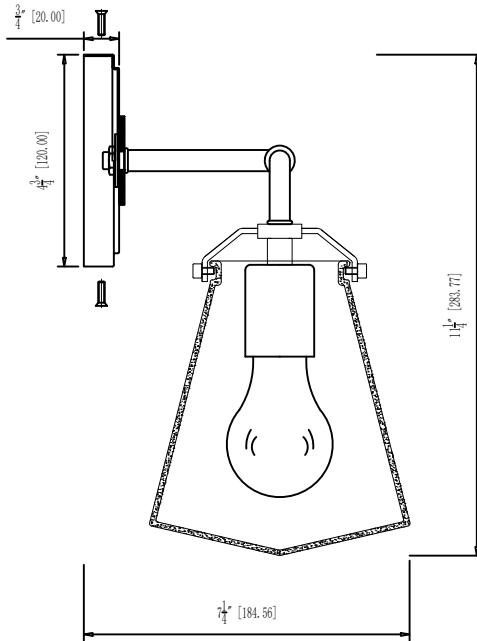

ASSEMBLY INSTRUCTION MODEL #VSS-7013-LG

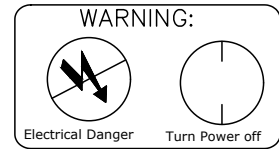

All electrical components must be installed by a licensed electrician in accordance with the National Electric Code and the appropriate local electrical codes.

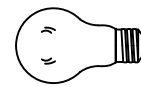

You will need 3 – Med. Bulb
60 Watts Recommended 100 Watts Max

USE LED BULBS FOR EXTENDED USE
This fixture is Damp rated.

How to Install

1. Install the mounting plate onto the outlet box using the two outlet box screws.
2. Place the frame over the mounting plate and secure with the screws.
3. Install the bulb onto the socket.
4. Slide the glass over the light cluster and let the spoke hold the glass by using the cap nuts. Do not over tighten it to prevent the glass from breaking.

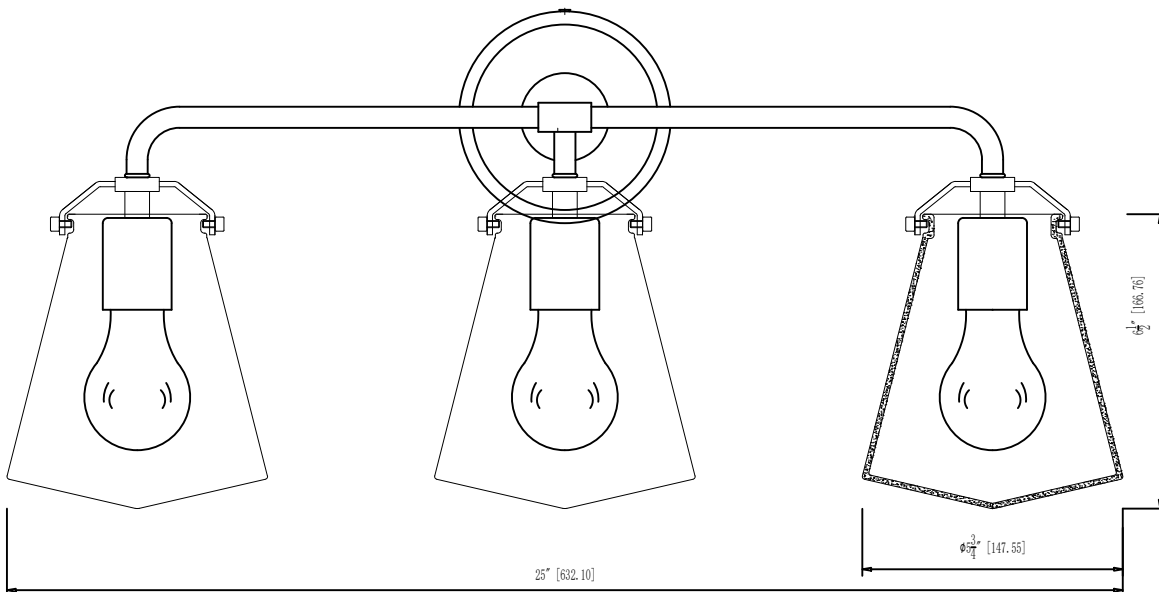

WARNING: This product can expose you to Lead, which is known to the State of California to cause cancer and/or birth defects or reproductive harm. For more information go to www.P65Warnings.ca.gov

CRYSTORAMA

LIGHTING THE WAY FOR SIXTY YEARS



ASSEMBLY INSTRUCTION MODEL #VSS-7013-LG

Part Number

Part Numbers

- A. (1)-Mounting hardware
- B. (1)-Frame
- C. (2)-Screws
- D. (1)-Light cluster
- E. (1)-Clear glass shade $\text{Ø}5.75'' \times \text{H}6.5''$
(XAR7001LGGLA5.75IN)
- F. (4)-Cap nut
- G. (1)-Backplate W4-3/4"xH3/4"
(XAR7001LGBKP4.75IN)

