



## Centaur Hybrid

1/2 Gas - 1/2 Charcoal

Model: CH50 LP/NG

**DESIGNED TO ENDURE.**  
The Centaur. The Best Of Both  
Worlds In One Grill

### FEATURES

Premium stainless steel frame,  
firebox, hood and burners.

Two high performance Coyote  
iBurners™ for the gas side and a full  
stainless charcoal drawer assembly

Crank assembly to control height/  
heat of charcoal

Interior hood lights on gas side

Double walled stainless steel hood

Includes premium stainless steel  
grates, warming rack and  
performance enhancing  
Heat Control Grids™

Continuous weld on grill box with  
seamless, polished edging

Integrated wind guard

Up to 40,000 BTU's on gas side



### OPTIONS

- Grill conversion kit available (gas side only)
- Stainless steel grill cart available
- Custom, weather resistant cover available
- Smoker box available
- 14" Drop in griddle (CGRDL) available



# COYOTE

Outdoor Living

## CH50 LP/NG

Overall Dimensions:  
25.5"(H) X 50"(W) X 23.75"(D)

Cutout Dimensions:  
13"(H) X 47.75"(W) X 21.25"(D)

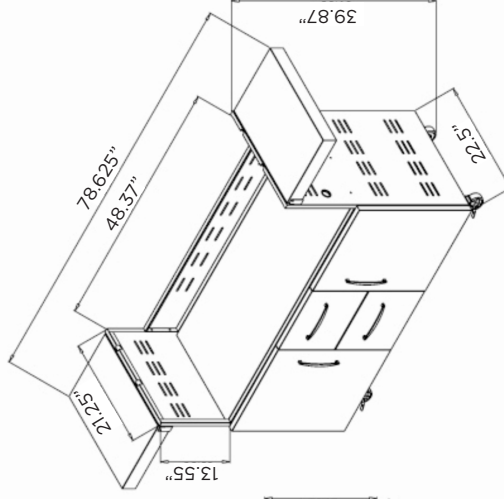
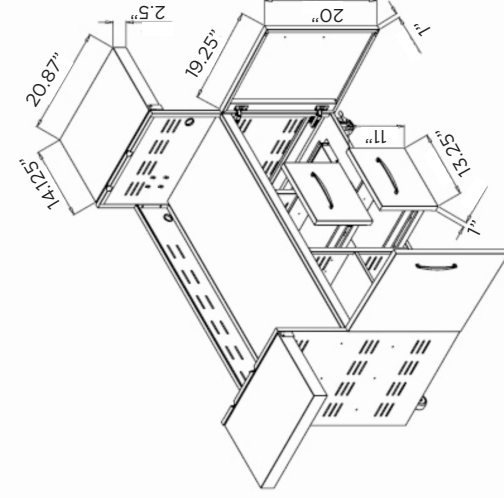
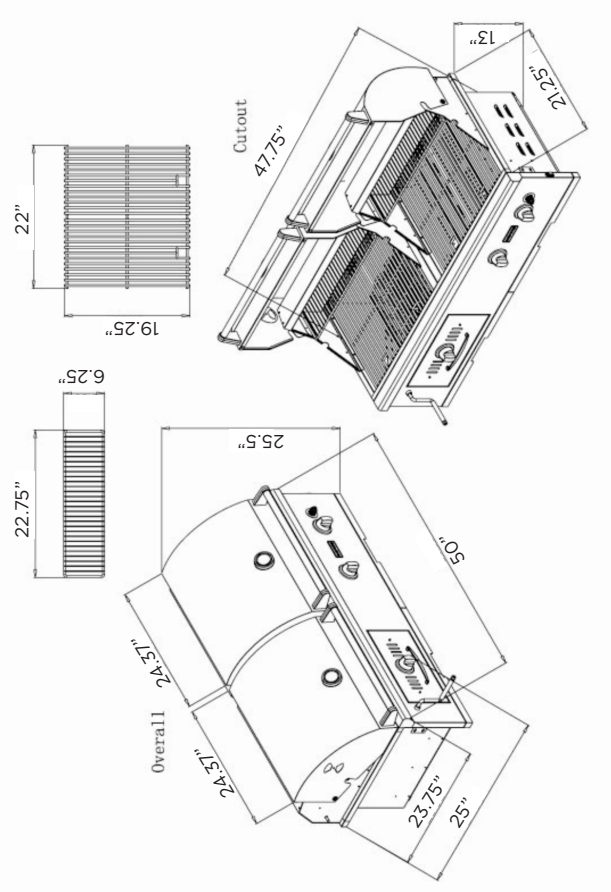

[www.coyoteoutdoor.com](http://www.coyoteoutdoor.com)

