

ROUGHING IN DIMENSIONS MAY VARY AND ARE SUBJECT TO CHANGE. NO RESPONSIBILITY IS ASSUMED FOR USE OF SUPERCEDED OR VOIDED DATA. (0192-1)

CHICAGO. FAUCETS

2100 SOUTH CLEARWATER DRIVE
DES PLAINES, ILLINOIS 60018-5999

FITTING NO.

GN2BVB

SUBMITTED MODEL NO.

JOB NAME

ITEM NO.

SUBMITTED AS SHOWN

SUBMITTED AS NOTED

SEE ATTACHED FOR
SUBMITTED MODIFICATION

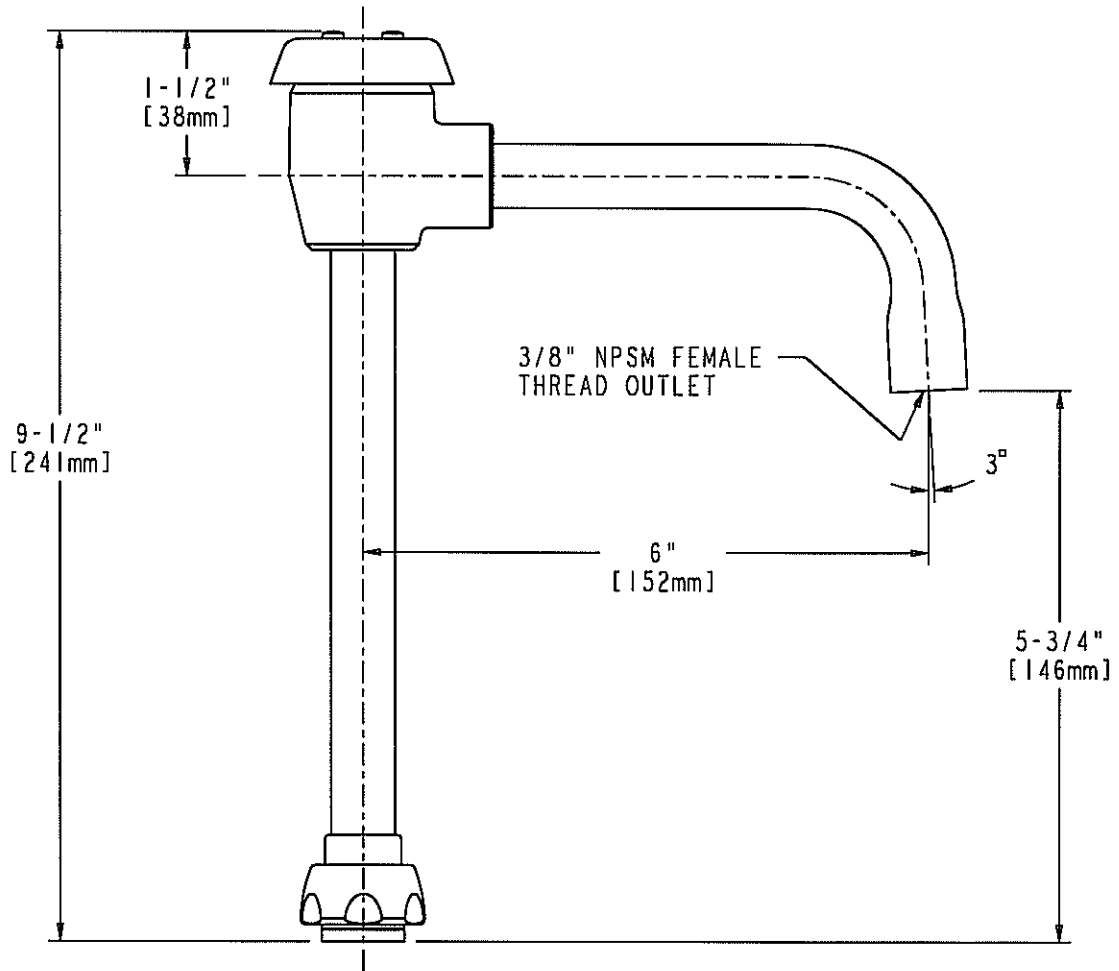

DIMENSIONS IN INCHES AND [MILLIMETERS].

TECHNICAL DATA

- RIGID/SWING VACUUM BREAKER SPOUT
- POLISHED CHROME FINISH OR AS SPECIFIED

DATE: 07-31-97

BY: MGM

CHK'D: *AT*

APP'D:

REV: 07-31-97

GN2BVB