

JOB NAME

ITEM NO.

SUBMITTED AS SHOWN

SUBMITTED AS NOTED

SEE ATTACHED FOR
SUBMITTED MODIFICATION



ADA COMPLIANT

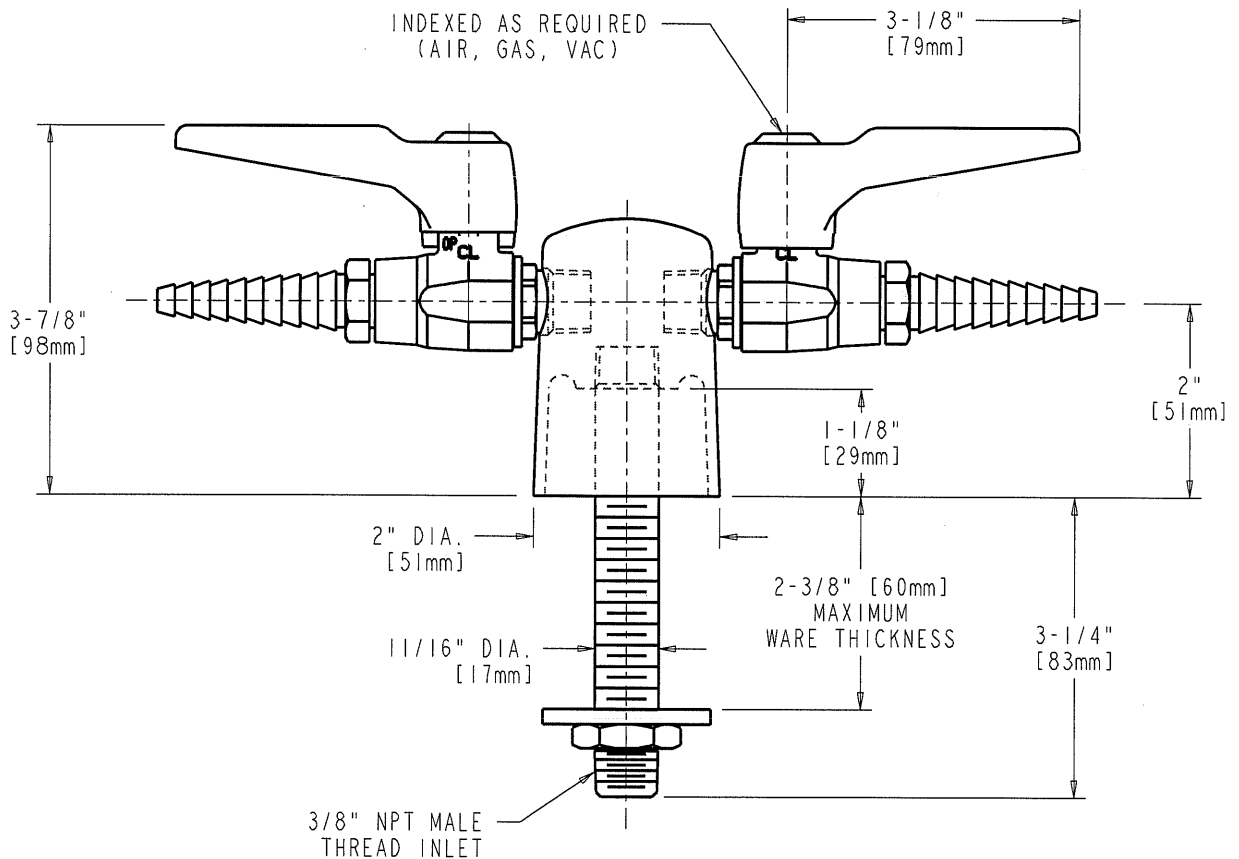
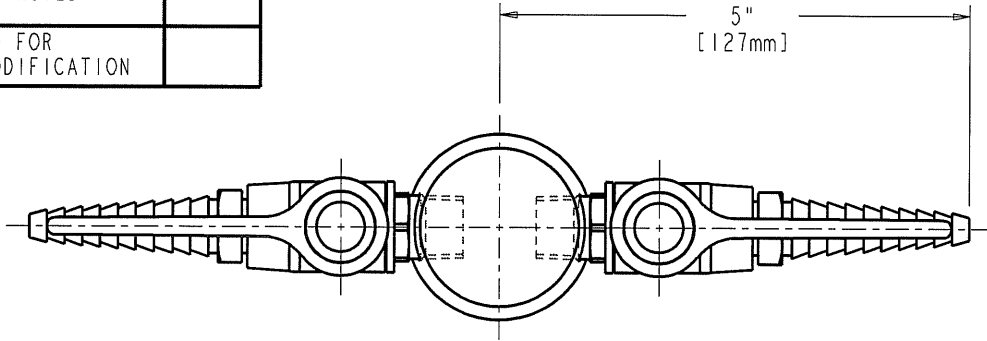

DIMENSIONS IN INCHES AND [MILLIMETERS].

TECHNICAL DATA

- TURRET WITH TWO BALL VALVES AT 180
- E7TC REMOVABLE SERRATED HOSE NOZZLE WITH CHECK
- AIR, GAS, AND VACUUM BUTTONS
- 957-3K INLET SHANK ASSEMBLY
- FINISH: CHROME PLATE
- 0.5-125 PSI MAXIMUM OPERATING PRESSURE
- ANSI Z21.15A
- CGA9.1M

DATE: 09-23-03

BY: SID

CHK'D:

APP'D: *AT*

REV: A

981-WSV909AGV

ROUGHING IN DIMENSIONS MAY VARY AND ARE SUBJECT TO CHANGE. NO RESPONSIBILITY IS ASSUMED FOR USE OF SUPERCEDED OR VOIDED DATA.