



a Geberit company

2100 South Clearwater Drive
Des Plaines, IL 60018
Phone: 847-803-5000
Fax: 847-803-5454
www.chicagofaucets.com

ROUGH-IN

FITTING NO.

943-WSLCP

BY: SID

DATE: 11-01-07

SUBMITTED MODEL NO.

CHK: *[Signature]*

REV:

FOR TECHNICAL ASSISTANCE
1-800-TEC-TRUE (1-800-832-8783)

SUBMITTED AS SHOWN

SUBMITTED AS NOTED

SEE ATTACHED FOR
SUBMITTED MODIFICATION

JOB NAME

ITEM NO.

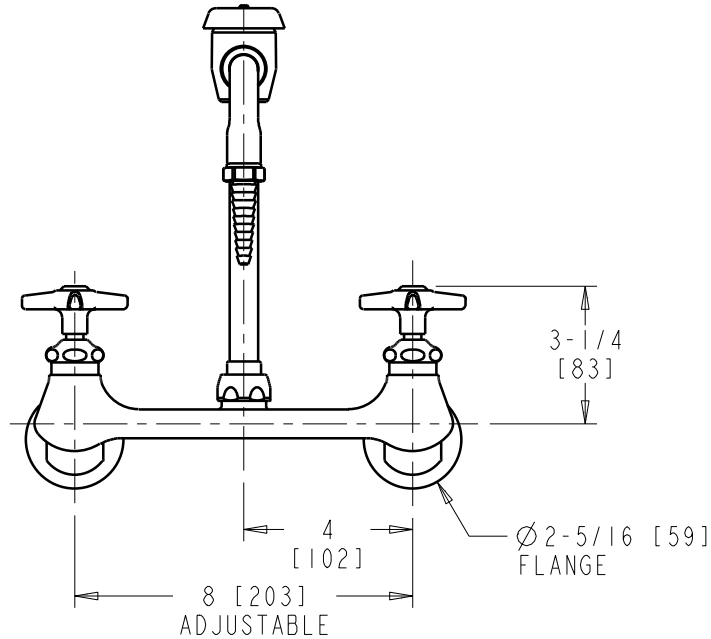

FRONT VIEW

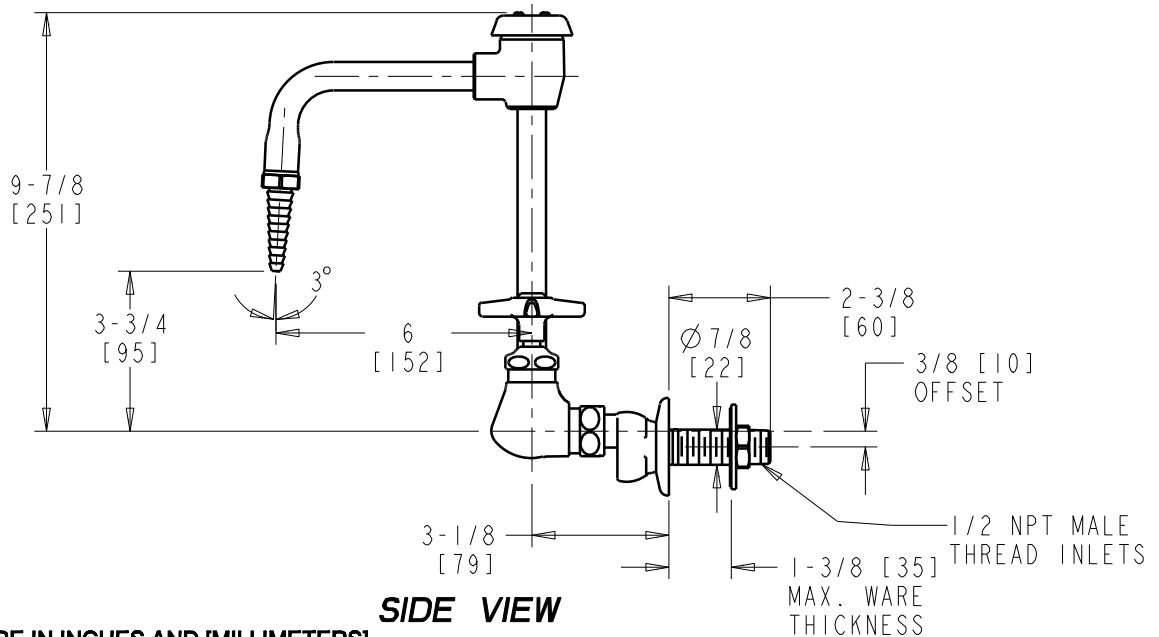

SIDE VIEW

DIMENSIONS ARE IN INCHES AND [MILLIMETERS].

TECHNICAL DATA

- WALL MOUNTED LABORATORY FITTING
- GN2BVB RIGID/SWING VACUUM BREAKER SPOUT
- 204 INDEXED 4-ARM HANDLES
- SLO-COMPRESSION OPERATING CARTRIDGES
- 'G' ADJUSTABLE SUPPLY ARMS
- 932-001K INLET SHANK ASSEMBLIES
- FINISH: CHROME PLATE
- E7 REMOVABLE SERRATED NOZZLE OUTLET
- ASME A112.18.1/CSA B125.1 COMPLIANT
- ASSE 1001 COMPLIANT

ROUGHING IN DIMENSIONS MAY VARY AND ARE SUBJECT TO CHANGE. NO RESPONSIBILITY IS ASSUMED FOR USE OF SUPERCEDED OR VOIDED DATA.