

CHICAGO[®] FAUCETS

2100 SOUTH CLEARWATER DRIVE
DES PLAINES, ILLINOIS 60018-5999

FITTING NO.

909-CAG

SUBMITTED MODEL NO.

JOB NAME

ITEM NO.

SUBMITTED AS SHOWN

SUBMITTED AS NOTED

SEE ATTACHED FOR
SUBMITTED MODIFICATION



ADA COMPLIANT

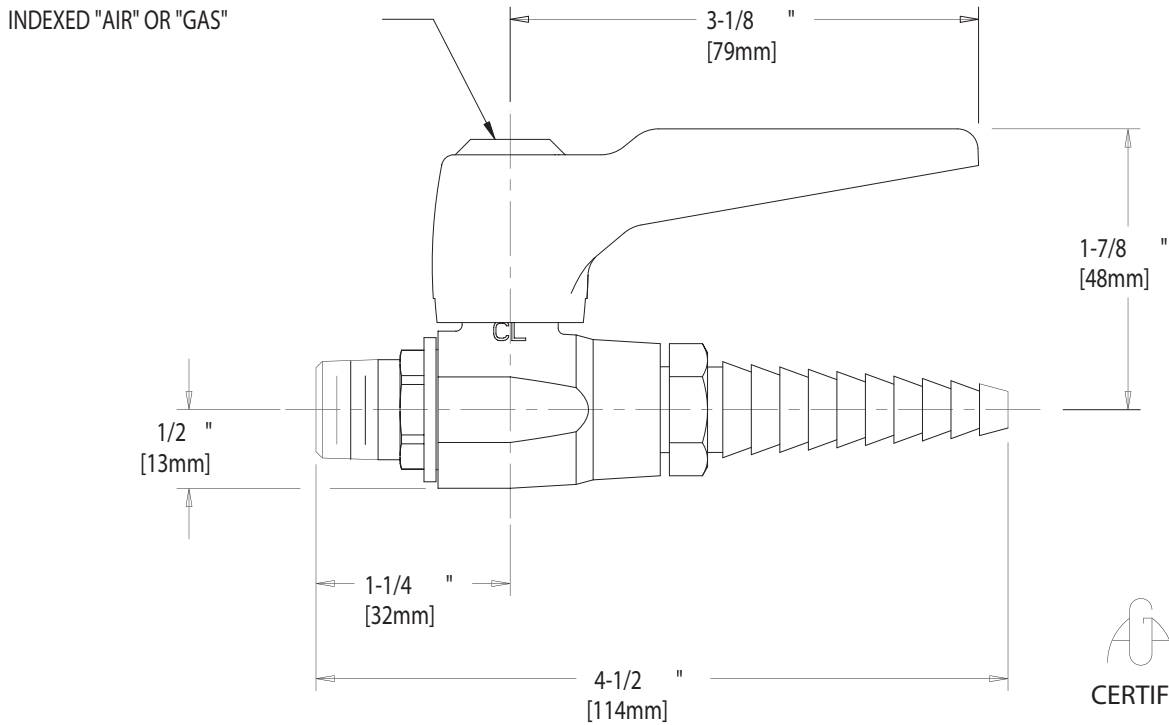
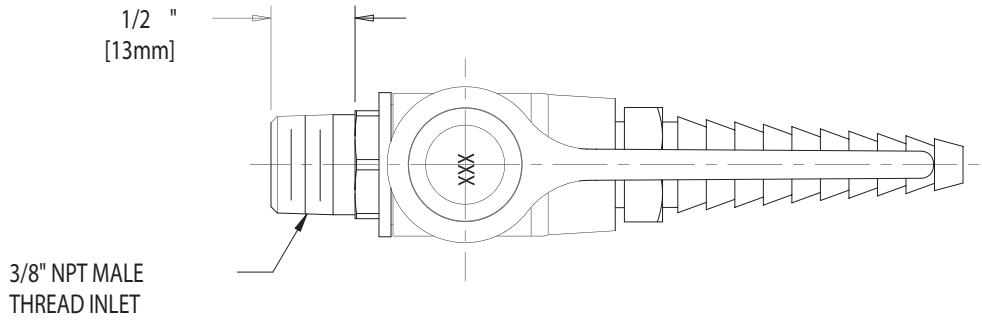

DIMENSIONS IN INCHES AND [MILLIMETERS].

TECHNICAL DATA

- GAS BALL VALVE WITH 3/8" NPT MALE THREAD INLET
- REMOVABLE SERRATED HOSE NOZZLE OUTLET WITH INTEGRAL CHECK VALVE
- LEVER HANDLE WITH INDEX BUTTON
- POLISHED CHROME FINISH OR AS SPECIFIED

- FOR USE WITH 0.5-125 PSI MAXIMUM WORKING PRESSURE
- ANSI Z21.15-1997
- CGA9.1-M97

DATE: 02-21-02

BY: JAR

CHK'D:

APP'D:

REV:

909-CAG

IS ASSUMED FOR USE OF SUPERCEDED OR VOIDED DATA. (0192-1)

ROUGHING IN DIMENSIONS MAY VARY AND ARE SUBJECT TO CHANGE. NO RESPONSIBILITY