

# CHICAGO FAUCETS

2100 SOUTH CLEARWATER DRIVE  
DES PLAINES, ILLINOIS 60018-5999

*Last As Long As The Building*

FITTING NO.

891-E2

SUBMITTED MODEL NO.

JOB NAME

ITEM NO.

SUBMITTED AS SHOWN

SUBMITTED AS NOTED

SEE ATTACHED FOR  
SUBMITTED MODIFICATION

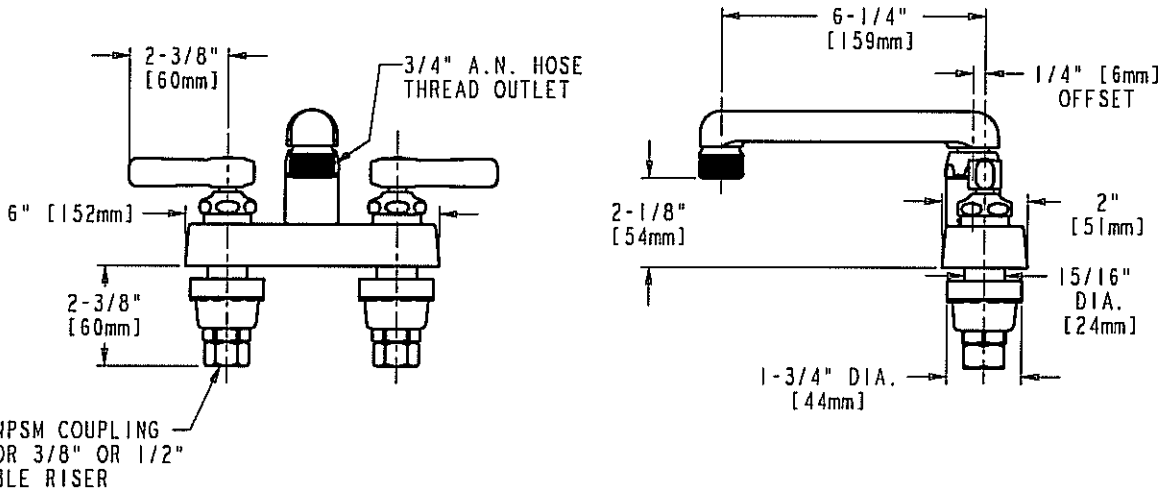

DIMENSIONS IN INCHES AND [MILLIMETERS]

TECHNICAL DATA

- DECK MOUNTED LAVATORY FAUCET
- S6 SWING SPOUT
- 369 INDEXED LEVER HANDLES
- QUATURN OPERATING CARTRIDGES
- FINISH: CHROME PLATE

- E2 HOSE THREAD OUTLET
- ASME A112.18.1M COMPLIANT
- CSA B125 COMPLIANT

DATE: 12-6-02

BY: JAR

CHK'D: *SLD*

APP'D:

REV: A

891-E2

ROUGHING IN DIMENSIONS MAY VARY AND ARE SUBJECT TO CHANGE. NO RESPONSIBILITY IS ASSUMED FOR USE OF SUPERCEDED OR VOIDED DATA.