

ROUGHING IN DIMENSIONS MAY VARY AND ARE SUBJECT TO CHANGE. NO RESPONSIBILITY IS ASSUMED FOR USE OF SUPERCEDED OR VOIDED DATA. (0192-1)

CHICAGO[®] FAUCETS

2100 SOUTH CLEARWATER DRIVE
DES PLAINES, ILLINOIS 60018-5999

FITTING NO.
886-R
SUBMITTED MODEL NO.

JOB NAME

ITEM NO.

SUBMITTED AS SHOWN	
SUBMITTED AS NOTED	
SEE ATTACHED FOR SUBMITTED MODIFICATION	

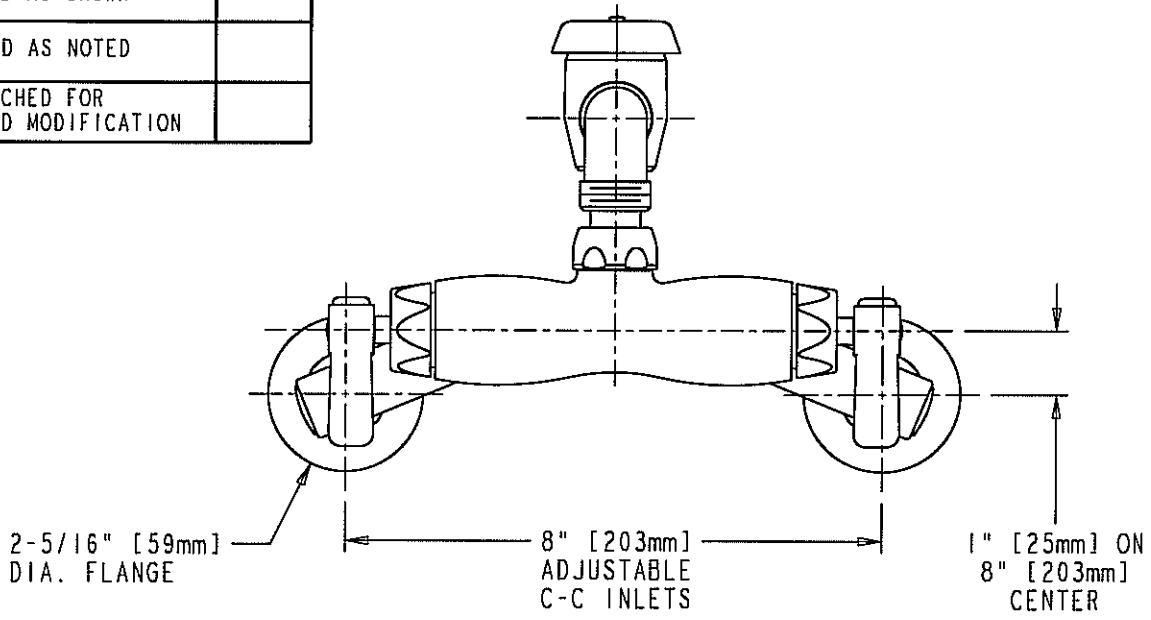

FRONT VIEW

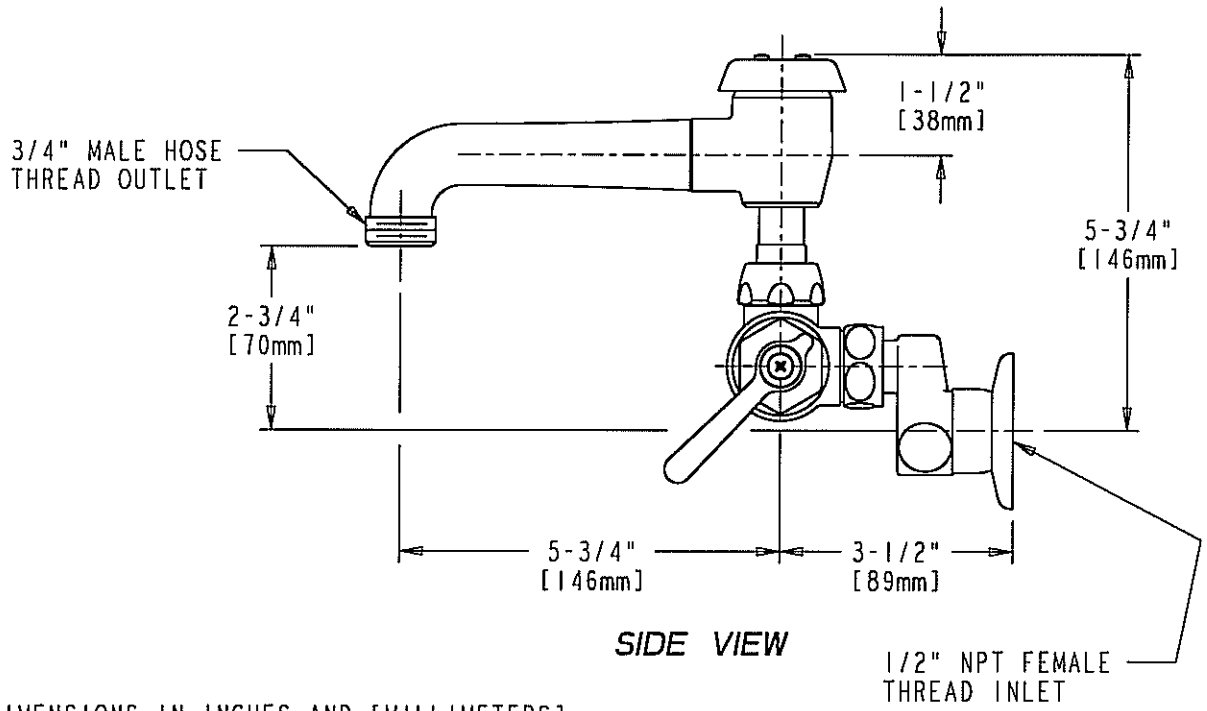

SIDE VIEW

DIMENSIONS IN INCHES AND [MILLIMETERS].

TECHNICAL DATA	
<ul style="list-style-type: none"> - BACK MOUNTED SINK FITTING - L5VB VACUUM BREAKER SWING SPOUT - 369 INDEXED LEVER HANDLES - QUATURN UNITS - 'R' ADJUSTABLE INTEGRAL STOP ARMS - POLISHED CHROME FINISH OR AS SPECIFIED 	<ul style="list-style-type: none"> - 3/4" MALE HOSE THREAD OUTLET - ANSI A112.18.1 COMPLIANT - CSA B125 COMPLIANT

DATE: 11-19-98
BY: MGM
CHK'D: <i>JJR</i>
APP'D: <i>ZK 12/1/98</i>
REV: 11-19-98

886-R