

CHICAGO FAUCETS



2100 SOUTH CLEARWATER DRIVE
DES PLAINES, ILLINOIS 60018-5999

FITTING NO.

814-VB

SUBMITTED MODEL NO.

Last As Long As The Building

JOB NAME

ITEM NO.

SUBMITTED AS SHOWN

SUBMITTED AS NOTED

SEE ATTACHED FOR
SUBMITTED MODIFICATION



ADA COMPLIANT

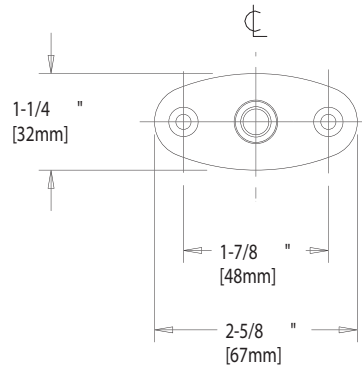

FLANGE DETAIL

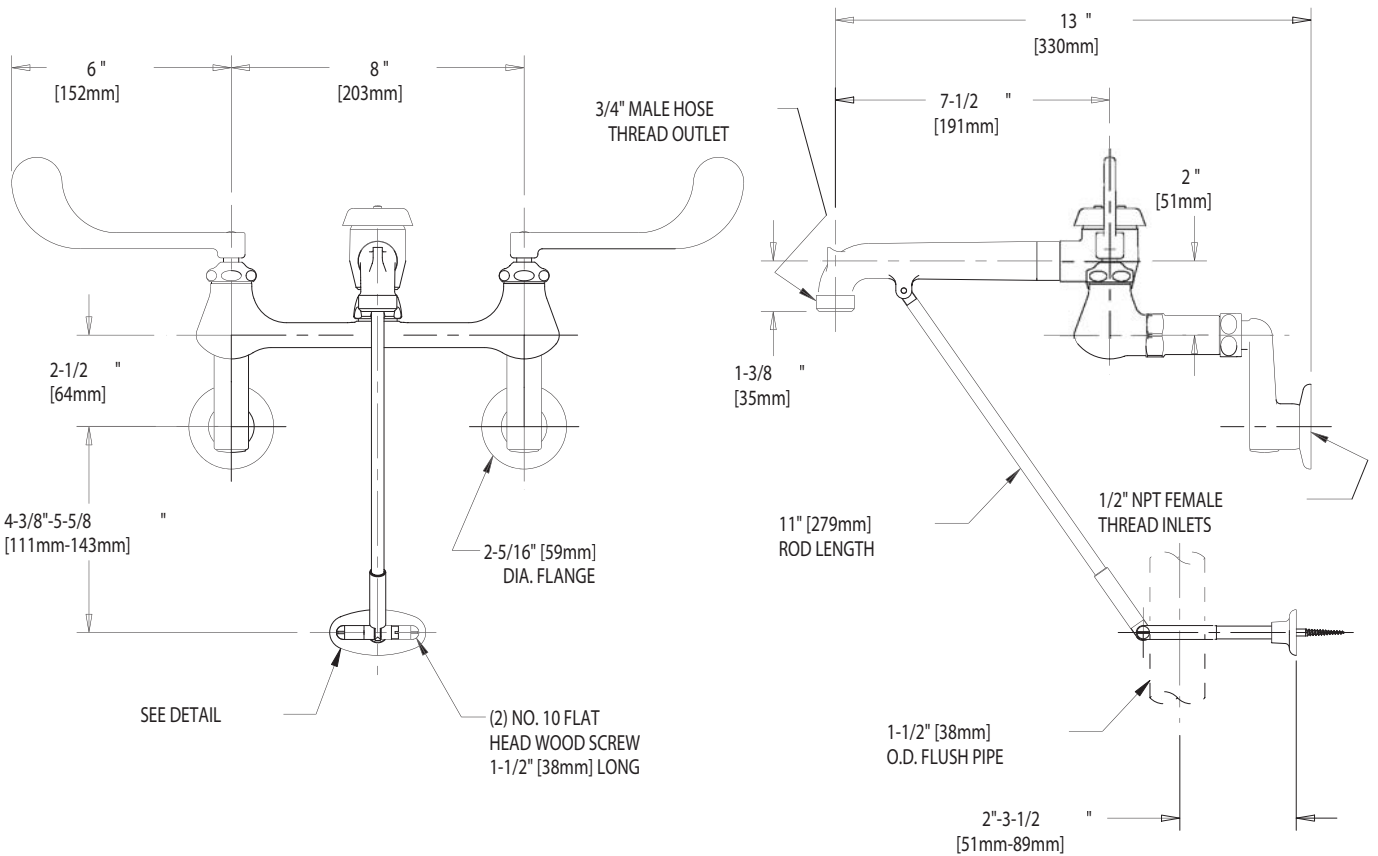

IS ASSUMED FOR USE OF SUPERCEDED OR VOIDED DATA.

ROUGHING IN DIMENSIONS MAY VARY AND ARE SUBJECT TO CHANGE. NO RESPONSIBILITY

DIMENSIONS IN INCHES AND [MILLIMETERS].

TECHNICAL DATA

- FLUSHING RIM SINK FITTING
- 814SVB RIGID SPOUT ASSEMBLY
- ATMOSPHERIC VACUUM BREAKER
- 319 ELBOW BLADE HANDLES
- QUATURN OPERATING CARTRIDGES
- FINISH: CHROME PLATE

- "R" ADJUSTABLE SUPPLY ARMS WITH INTEGRAL SERVICE STOPS
- FLUSH VALVE PIPE SUPPORT
- ASME A112.18.1M COMPLIANT
- CSA B125 COMPLIANT

DATE: 05-20-02

BY: SID

CHK'D:

APP'D:

REV: A

814-VB