

CHICAGO FAUCETS

2100 SOUTH CLEARWATER DRIVE
DES PLAINES, ILLINOIS 60018-5999

Last As Long As The Building

FITTING NO.

733

SUBMITTED MODEL NO.

JOB NAME

ITEM NO.

SUBMITTED AS SHOWN

SUBMITTED AS NOTED

SEE ATTACHED FOR
SUBMITTED MODIFICATION

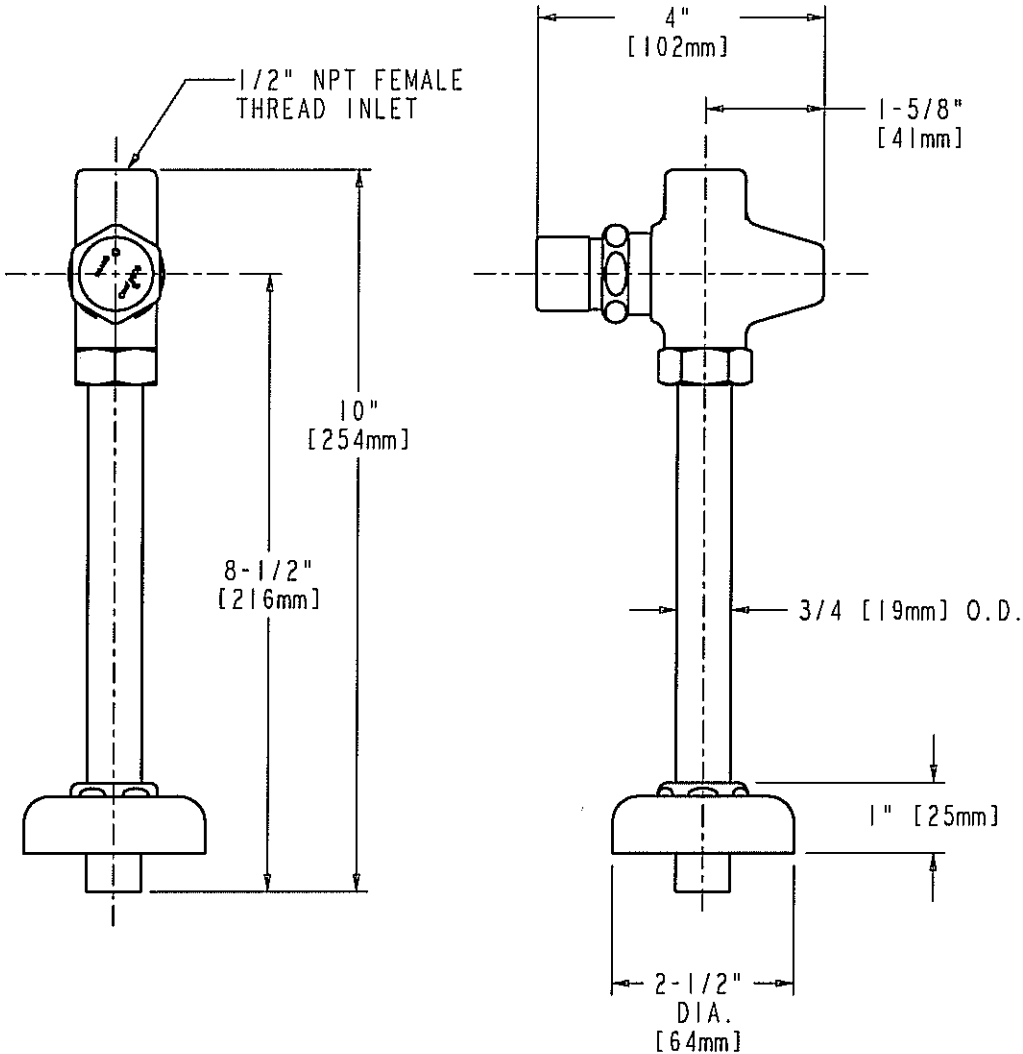

DIMENSIONS IN INCHES AND [MILLIMETERS].

TECHNICAL DATA

- ANGLE VALVE
- 333 NAIAD SELF CLOSING VALVE AND HANDLE
- NAIAD SELF-CLOSING CARTRIDGE
- TAILPIECE AND ESCUTCHEON ASSEMBLY
- FINISH: CHROME PLATE

- ASME A112.18.1M COMPLIANT
- CSA B125 COMPLIANT

DATE: 11-21-02

BY: JAR

CHK'D: *SLD*

APP'D:

REV: A

733

ROUGHING IN DIMENSIONS MAY VARY AND ARE SUBJECT TO CHANGE. NO RESPONSIBILITY IS ASSUMED FOR USE OF SUPERCEDED OR VOIDED DATA.