

# CHICAGO FAUCETS®

2100 SOUTH CLEARWATER DRIVE  
DES PLAINES, ILLINOIS 60018-5999

Last As Long As The Building

FITTING NO.

404-VE2805-950

SUBMITTED MODEL NO.

JOB NAME

ITEM NO.

SUBMITTED AS SHOWN

SUBMITTED AS NOTED

SEE ATTACHED FOR  
SUBMITTED MODIFICATION

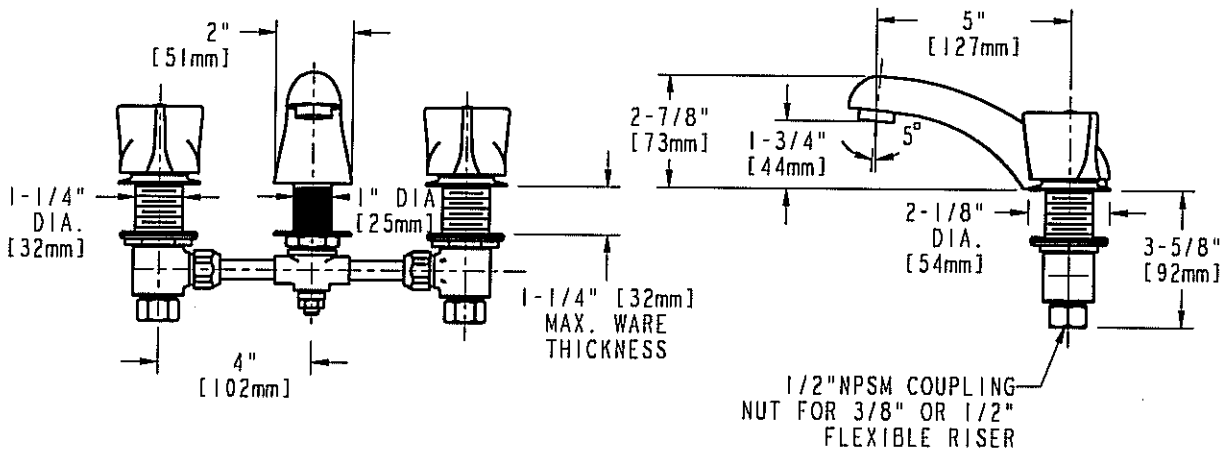

DIMENSIONS IN INCHES AND [MILLIMETERS].

TECHNICAL DATA

- DECK MOUNTED FAUCET
- 5" CAST BRASS POUT
- 950 INDEXED THREE WING HANDLES WITH VANDAL RESISTANT SCREWS
- QUATURN OPERATING CARTRIDGES
- FINISH: CHROME PLATE

- E2805 VANDAL RESISTANT ECONOFLO AERATOR
- 0.5 GPM [1.9 L/min.] MAXIMUM FLOW RATE
- ASME A112.18.1M COMPLIANT
- CSA B125 COMPLIANT
- NSF 61 COMPLIANT

DATE: 8-23-02

BY: JAR

CHK'D: *S/D*

APP'D:

REV: A

404-VE2805-950

ROUGHING IN DIMENSIONS MAY VARY AND ARE SUBJECT TO CHANGE. NO RESPONSIBILITY IS ASSUMED FOR USE OF SUPERCEDED OR VOIDED DATA.