

## HowTO install

# BarnDoorTrack™

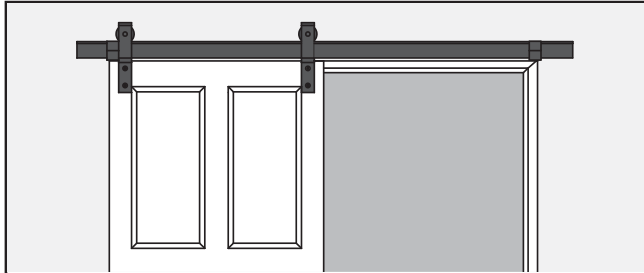

### Before you start:

CS Barn Door Track is suitable for surface sliding applications where there is enough strength in the wall to mount a track above the doorway. Ensure the stud wall is level and solid enough to support the door weight.

This track is supplied with coach screws suitable for use with timber framing. For fixing to concrete walls, masonry anchors must be used. You may need to open the existing holes to suit the type of masonry anchor you have selected.

Ensure that you have enough clearance above the door opening to mount the track bracket and hanger pins, and that there is adequate support for the weight of the door.

### Determine overall thickness

1. This track system is supplied with either a Narrow or Wide track bracket which can be adjusted to suit an overall thickness of door + gap + architrave of:  
40 - 61mm (1-5/8" to 2-3/8") (Narrow option) or  
62 - 80mm (2-3/8" to 3-1/8") (Wide option).

**Note:** The Wide Option is shipped with the track bracket upside down due to shipping constraints. Make sure you install as per **diagram 1** below.

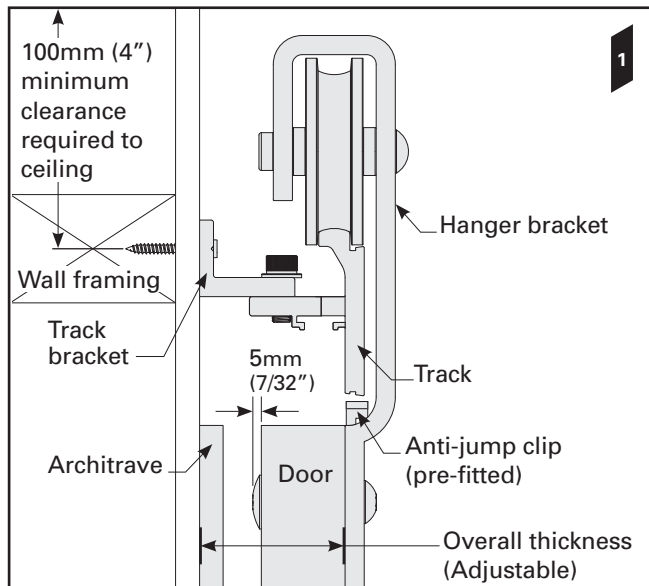

### Cut a groove in the bottom of the door

2. At the bottom of the door leaf cut a groove to the dimension and tolerance shown. Make it central to the door thickness and absolutely straight.

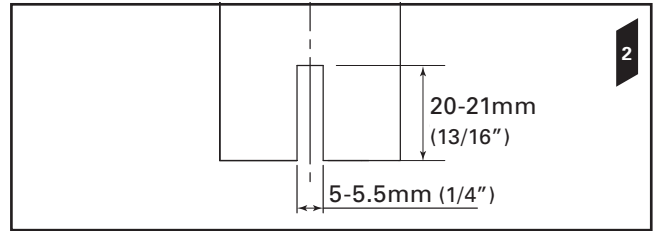

### Mark position of track bracket and floor guide

3. Manually position the door in the desired 'open' position. Mark position 'O' on the floor and wall as shown.

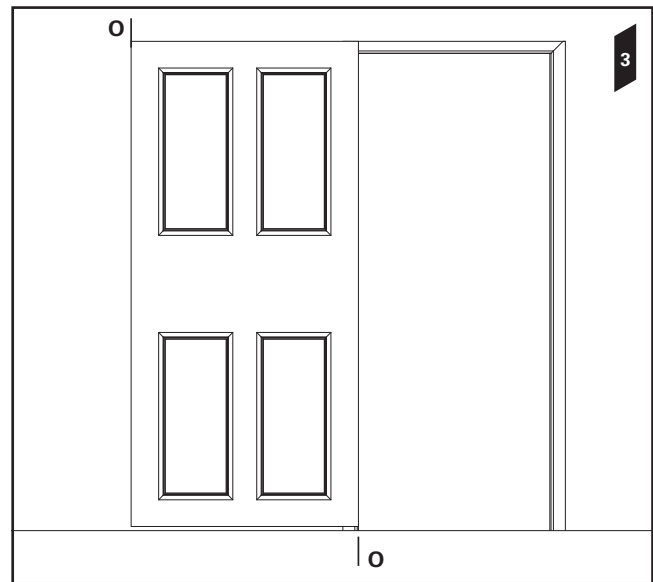

4. Manually position the door in the desired 'closed' position. Mark position 'C' on the floor and wall as shown. Check that there is enough room between O and C to fit the floor guide. Reposition O or C if necessary.

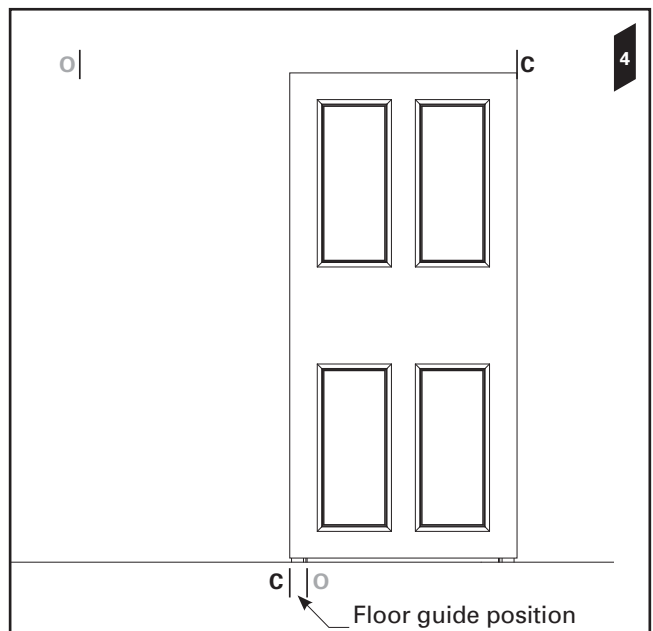

Go to page **2** (overleaf) →

5. The mid point between position **O** and **C** above the door will be the centreline of the track (**X**). Work out the fixing height (**H**mm above the finished floor level). Ensure there is enough clearance above the track to mount the door.

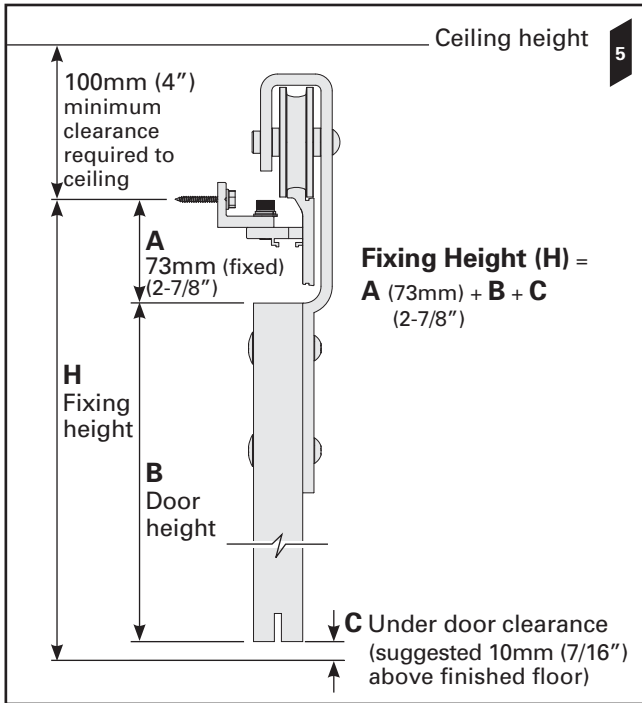

6. Mark central fixing point (**X**).

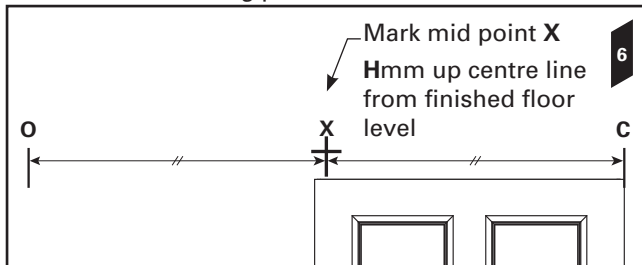

**Fix track bracket to wall**

7. Drill a  $\phi 3.5\text{mm}$  (1/8") hole, 50mm (2") deep into the wall on point **X**. Using this hole, screw the centre hole of the track bracket on to the wall using one of the coach screws supplied.
- Note:** There must be a 10mm (1/2") gap below the bottom of the mounting bracket. Cut architrave if required.

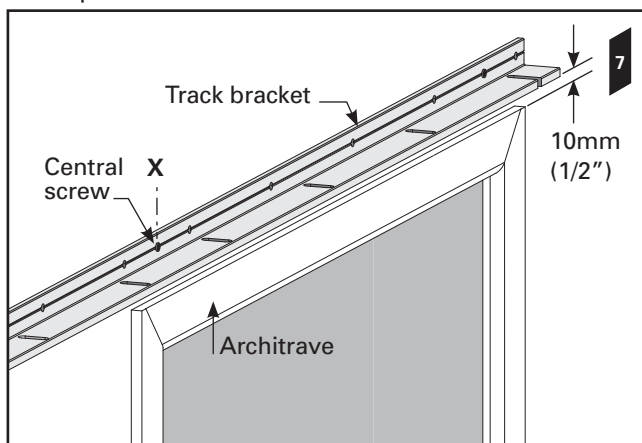

Level track bracket by pivoting around central screw. Lock in place with two outer screws.

**Pre-drill and fix track bracket**

8. The track bracket must be fixed to solid timber with coach screws. If the pre-drilled mounting holes don't align with a head joist or stud, additional  $\phi 7\text{mm}$  (9/32") holes should be drilled along the guide channel. All of the supplied coach screws must be used. Do not drill within 15mm (5/8") of the adjustment slot or the coach screw will interfere with track adjustment.
- Pre-drill through the centre of all mounting holes with a  $\phi 3.5\text{mm}$  (1/8") drill bit to help centre the coach screws.

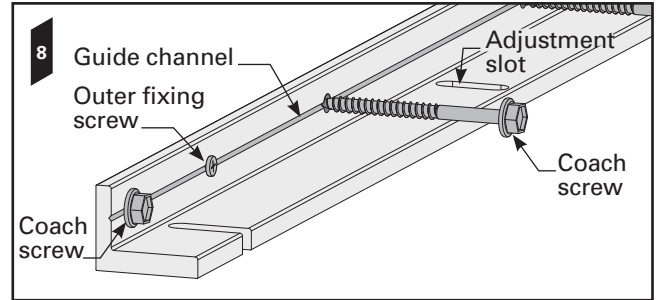

9. Slide track onto the bracket and immediately fix the track to the bracket with bolts and washers to ensure track does not fall off.

**Do not fully tighten bolts yet.**

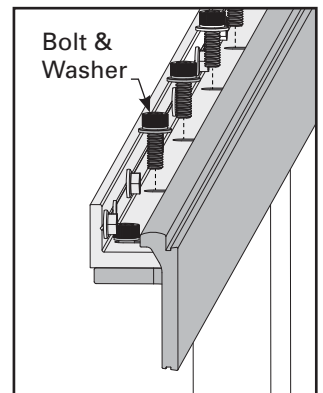
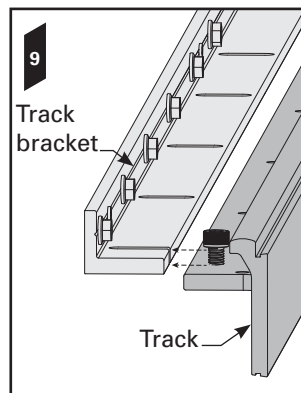

**Extend and tighten**

10. Adjust track to fully extended position and tighten the bolts. Remove end bolts and fit with washers before refitting.

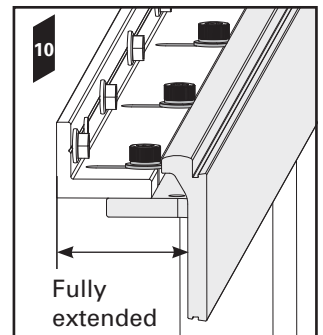

**Position hangers**

11. Place hangers on door and decide offset of hanger from edge of door (**X**). Use a square to mark a line on both outer edges.

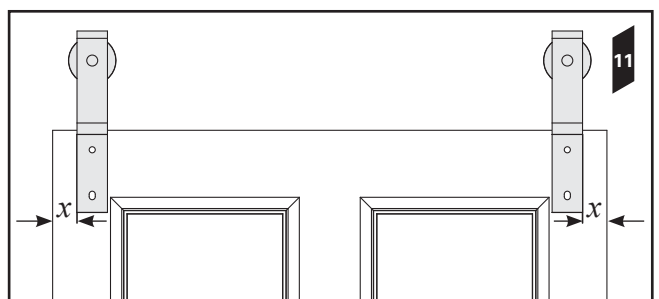

**12.** Hold hangers to door, aligning edge **A** with top of door and edge **B** with marked line.

Clamp in place and mark centre of **Hole 1** and **Slot 2** onto face of door for drilling reference.

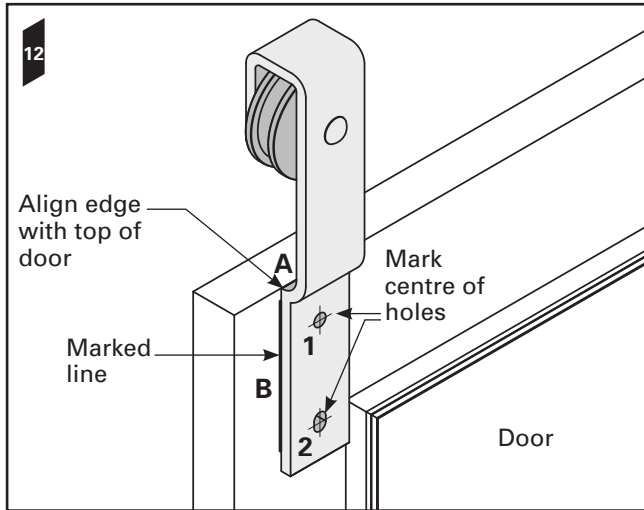

**Fasten hangers to door**

**13.** Pre-drill through door using  $\varnothing 8\text{mm}$  ( $5/16''$ ) drill bit. Ensure holes are perpendicular to front face of door. Drill out with  $\varnothing 12\text{mm}$  ( $15/32''$ ) drill.

**14.** Check alignment of hanger and fasten to door with door bolts supplied. Do not over-tighten.

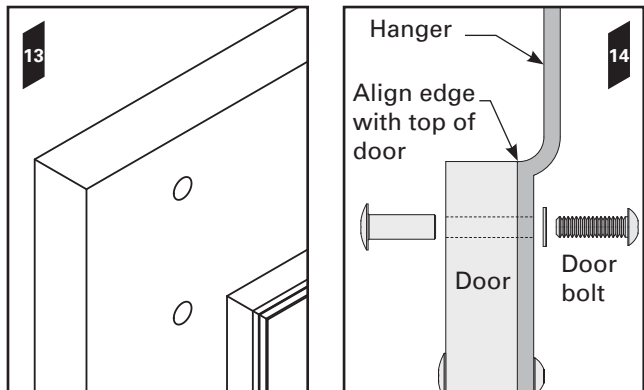

**If you are installing SofStop, follow steps 20-21, Page 4 to fit the activator to the top of the door.**

**Adjust track offset**

**15.** Before lifting the door onto the track, check the clearance. Loosen all bolts one turn and adjust the track so that the door will be at the desired offset from the wall. Re-tighten bolts.

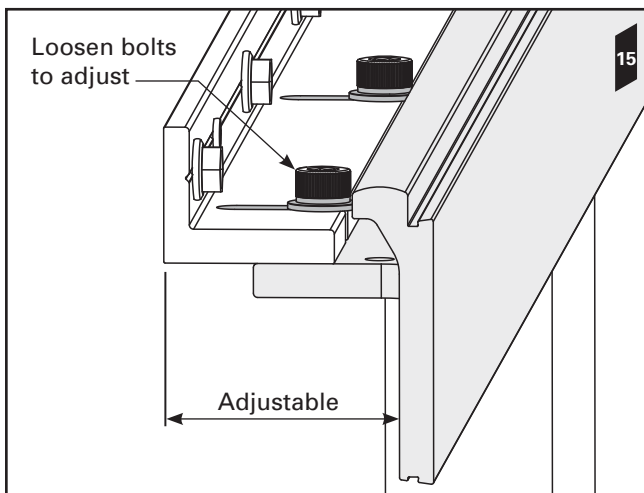

**Lift door onto track**

**16.** Lift the door onto the track.

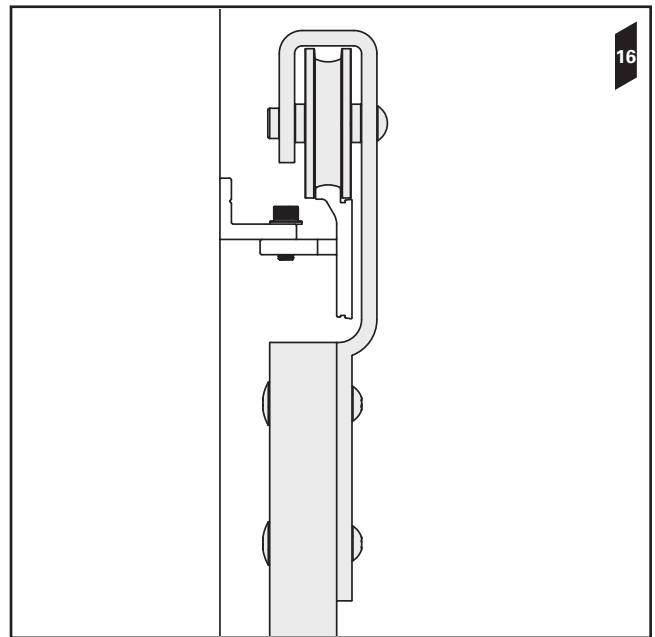

**Check T-Guide position**

**17.** Ensure the T-Guide is between point **C** and **O** marked on the floor and the desired distance away from the wall.

**18.** Roll door back far enough to mount T-Guide. If this means rolling off the end of the track, ensure door weight is supported using a block.

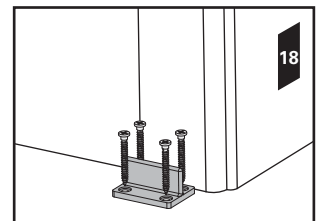
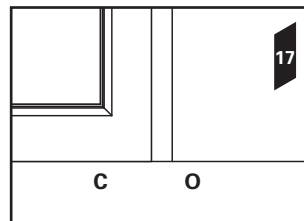

**Position stops**

**19.** Move door to the open position.

Position rubber part of stop against hanger as shown. Tighten cap screws to lock stop in place. Close the door and repeat for the other stop.

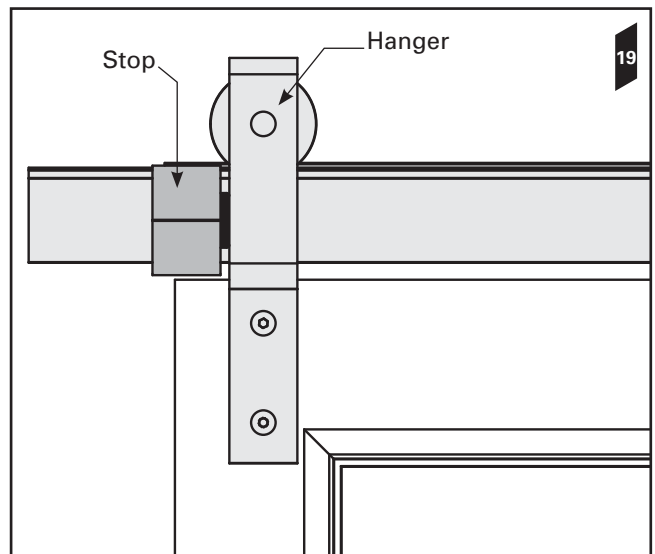

**If you are installing SofStop, turn to Page 4 →**

## Install Activator into Door

20. If door is installed, remove it from the track.

Mark a centre line on the top edge of the door.

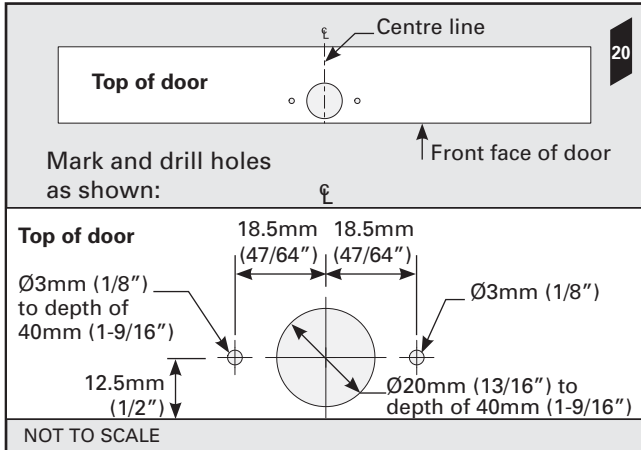

21. Check activator head is flush with the bolt. This is necessary in order to reconnect the door to the track. Screw activator to top of door using supplied screws.

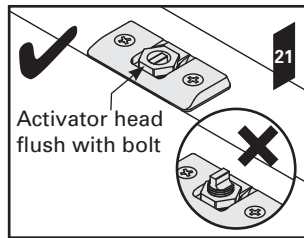

Continue with track installation (Step 15, Page 3)

### Position SofStop cassette:

Install door on the track then follow **Option A** or **B**.

Note: Cassette can be installed charged or uncharged.

#### Option A:

##### Open track ends method.

22. Loosely connect the rivnut plates to the SofStop cassette using the supplied washers and M5 socket head screws.

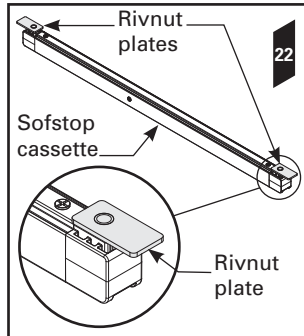

23. Align rivnut plates of the assembled SofStop cassette with the groove on the underside of the track. Check SofStop dampener is in the correct orientation and slide the cassette down the track. **Go to step 25.**

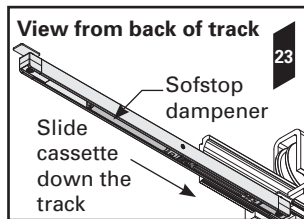

#### Option B: Limited space on end of track.

24. If there is limited space, slide one rivnut plate into grooved slot on underside of track.

Attach second rivnut plate loosely on the opposite end of the cassette.

Check SofStop dampener is in the correct orientation and slide the cassette down the track. Align cassette with the first rivnut plate and loosely screw plate to the cassette.

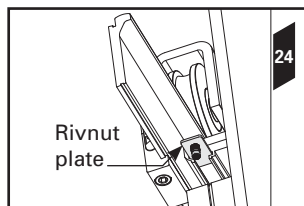

## Align Unit and Test.

25. Move door into closed position.

Slide SofStop cassette to align activator head with the unit claws.

Open door and tighten screws on rivnut plates to lock SofStop in position.

Close door and check alignment. Loosen rivnut plates to adjust position if required, then re-tighten.

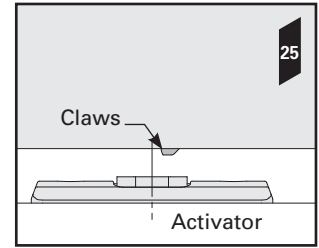

26. With the door closed, use the lifting tool to pick up the activator nut then slide the tool under the nut.

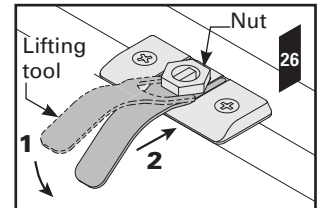

27. Using the supplied spanner raise the activator head to its marked position by tightening the nut.

NOTE: Check that activator head is high enough to interact with the claws of the SofStop unit. Keep tightening if head is not tall enough.

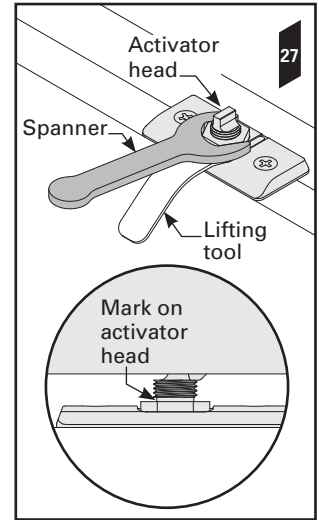

28. Pull lifting tool out to drop nut back into seated position.

29. Test SofStop works by opening and closing the door. Check that the unit won't slide out of position if the door is closed faster than usual. Adjust or tighten if necessary.

30. For units requiring **Soft Open and Soft Close**, repeat steps above to install a SofStop cassette at the other end of the track. Only one activator is required on the door.

#### NOTE:

- If the unit doesn't activate, the activator head is not tall enough. **Repeat Steps 26 - 27 to adjust.**
- If the door does not close to the desired position repeat **Step 25.**

# CavitySliders

Quality Sliding Door Hardware

5 - 7 Rakino Way  
Mt Wellington  
Auckland 1060

1/7-11 Rodborough Rd  
Allambie Heights  
NSW 2100

548 Finney Ct,  
Gardena, 90248 CA  
USA

csfordoors.co.nz

cavitysliders.com.au

cavitysliders.com

All copyright and other property in this document is reserved by Cavity Sliders Ltd. Details and specifications are subject to change without notice. Whilst all care is taken to ensure the accuracy of all information, no responsibility will be accepted for any errors or omissions. \*Guarantee conditions apply. Contact Cavity Sliders Ltd for details.

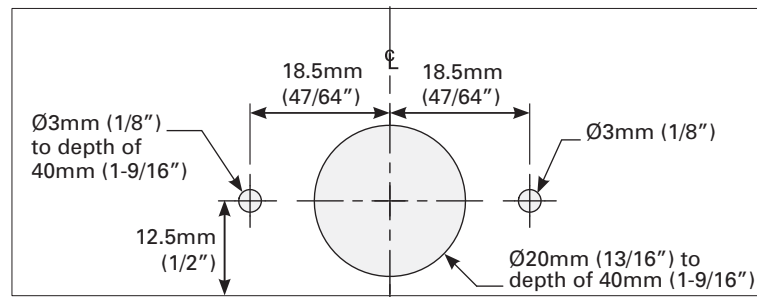

Line template up with centre line on front edge of top of door

