

CL400[®] Magnetic

1
PAGE

Installation Instructions for CL400 Bi-Parting Passage (Latching) Handles

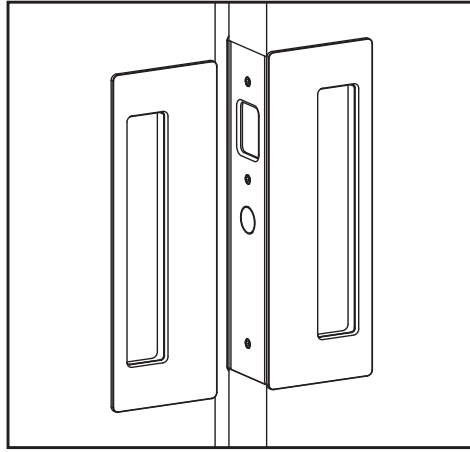

Before you Start:

1. These handles have been manufactured to specifications which **cannot** be altered by the installer. These include:

- a **Handle type:** the CL400 handle is available in *Passage, Privacy, Key Locking* and *Bi-Parting* versions. You have purchased the **Bi-Parting Passage (Latching)** version.
- b **Configuration:** the Passage handle configurations include; *Passage Latching* and *Passage Non Latching*.
- c **Handing** (Passage handles are not handed).
- d **Door thickness range:** the CL400 handle is available in four door thickness ranges. These are: 34-40mm, 40-46mm, 46-52mm and 52-58mm (1-3/8" to 1-9/16", 1-5/8" to 1-3/4", 1-13/16" to 2" and 2-1/16" to 2-1/4").

Refer to the information printed on the *Side Handle* and *Chassis* boxes to ensure you have purchased the handles with the correct specifications for your situation. **If the specifications are incorrect you will need to exchange the handles.**

- 2. Component drawings have been provided. Please familiarise yourself with the components and check the package to ensure nothing is missing.
- 3. To ensure the handles latch accurately, it is essential that both doors are adjusted for height and are parallel with each other when closed **before** installing the handles.
- 4. The CL400 is a metric handle. **Accurate measurements are shown in millimetres. Conversions to inches are approximate.**

Door Preparation

- 1. Mark a line on the face of the doors where the centre of the handles are to be positioned. Align the centre line on the *door cut out template* with the centre line on the door. Follow the instructions on the template. Repeat cut out for both doors.

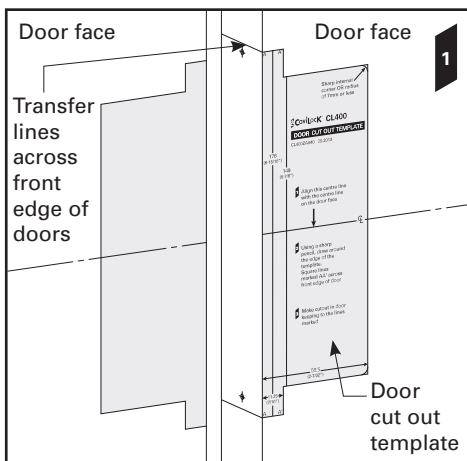

- 2. Mark two holes in the centre of the door thickness in the positions shown. Using these marks, drill two 2.5mm (3/32") diameter holes to a depth of 35mm (1-3/8").

Repeat holes for both doors.

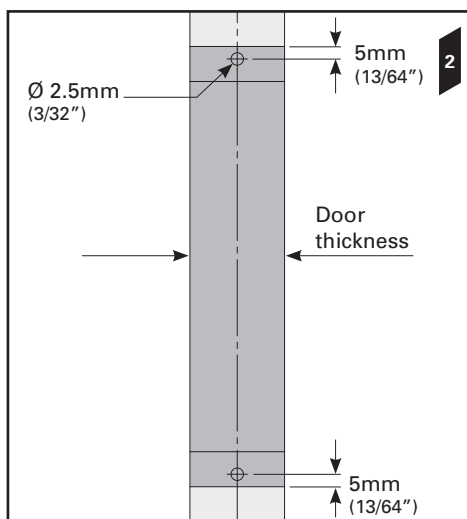

Fitting the Bi-Parting Mate

- 3. The Bi-Parting chassis contains a strong magnet. **Read the warning on page 2 before continuing.**

Remove the *Bi-Parting chassis* from its packaging. Remove the *face plate screw* and *face plate* from the chassis.

Align the chassis with the centre of the door thickness. Screw the chassis to the door (using the two *chassis mounting screws*) through the slotted holes at the top and bottom of the chassis. **DO NOT** fully tighten the screws.

Realign the chassis with the centre of the door thickness. When happy with the chassis position, fully tighten the screws.

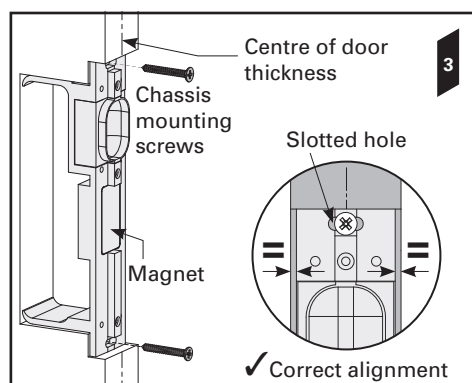

- 4. Fit the 6x *side handle to chassis screws*. Leave a 3mm gap (1/8") between the underside of the screw head and the chassis.

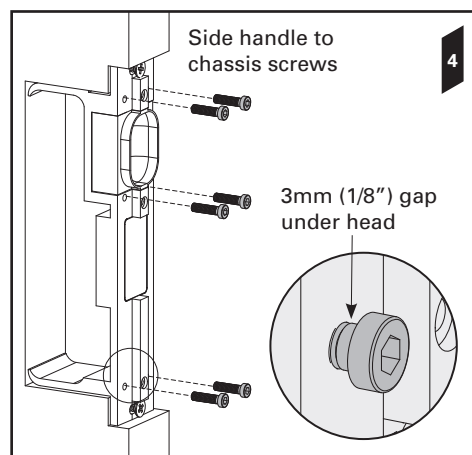

3
PAGE

IMPORTANT: Install THIS handle FIRST

Component Drawings - Bi-Parting Mate

Bi-Parting Side Handle Box

- a Bi-Parting Side Handle (Left)
- b Bi-Parting Side Handle (Right)

Bi-Parting Chassis Box

- c Bi-Parting Face Plate
- d Bi-Parting Chassis
- e Magnet
- f Chassis Mounting Screws (2)
- g Side Handle to Chassis Screws (6)
- h Handle Face Plate Screws (3)

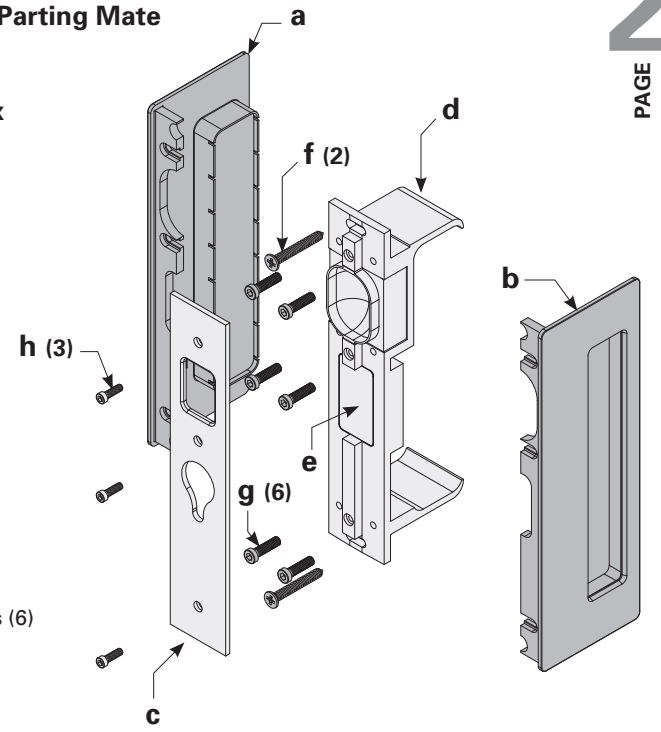

Tools (contained in Bi-Parting Chassis Box)

- i CL400 Allen Key (used for all machine screws)

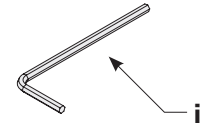

WARNING: THE BI-PARTING CHASSIS CONTAINS A STRONG MAGNET

IRON FILINGS - Magnets will attract shavings from iron or ferrous metals which may be hard to remove. Keep magnets a safe distance away from these materials.

DANGER FOR CHILDREN - Magnets may cause serious injury if swallowed. Keep out of reach of children.

CRUSHING, BLISTERS AND CUTS - Fingers may become caught between magnets resulting in crushing, blisters or cuts.

BREAKING OR CHIPPING - It is possible that magnets could chip or shatter on contact, resulting in chips flying off at high speed into someone's eye. Chips can also be very sharp - treat them as you would broken glass.

MAGNETICALLY SENSITIVE ITEMS - Keep a safe distance between the magnet and all objects that can be damaged by magnetism (e.g. mechanical watches, pacemakers, cell phones etc.).

DISPOSAL - Magnets should be disposed of carefully and in accordance with your local regulations.

Fitting the Bi-Parting Mate

- 5. Fit one of the *Bi-Parting side handles* (left OR right) to the chassis by sliding the front flange of the handle under the heads of the 3x *side handle to chassis screws*. Tighten the screws.

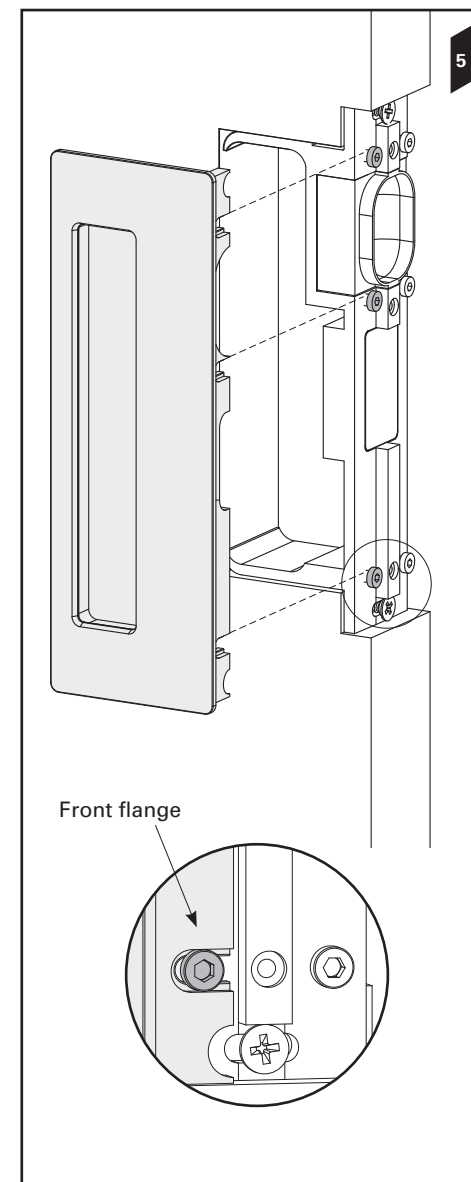

- 6. Fit the remaining Bi-Parting side handle to the chassis and tighten the screws.

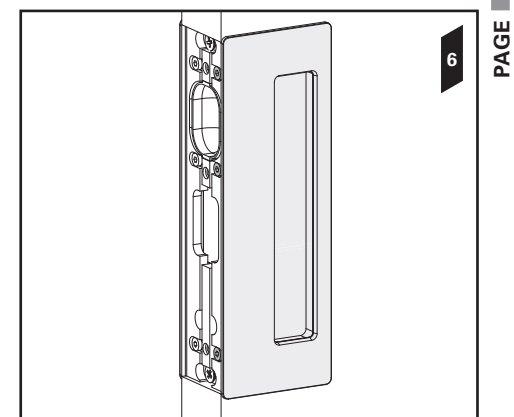

- 7. Fit the *Bi-Parting face plate* to the chassis using the 3x *handle face plate screws*.

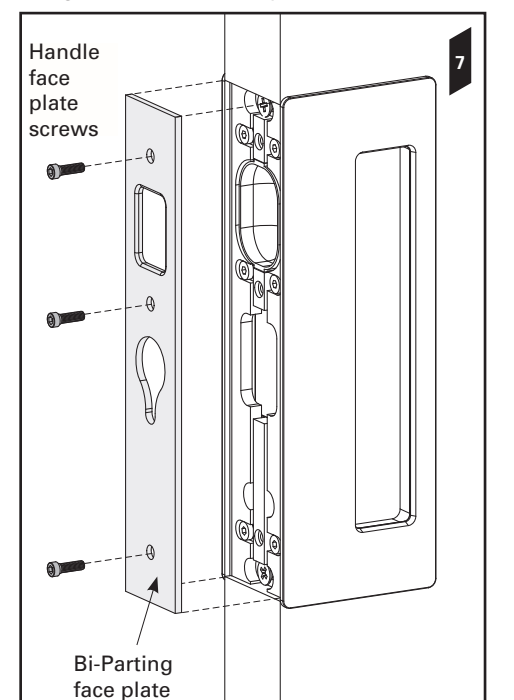

Go to page 5 (overleaf) →

2
PAGE

4
PAGE

Component Drawings - Passage Handle

Passage Side Handle Box

- j** Passage Side Handle (Left)
- k** Passage Side Handle (Right)

Passage Chassis Box

- l** Passage Face Plate
- m** Passage Chassis
- n** Plunger
- o** Plunger Nut
- p** Spring Reservoirs (2)
- q** Chassis Mounting Screws (2)
- r** Side Handle to Chassis Screws (6)
- s** Handle Face Plate Screws (3)

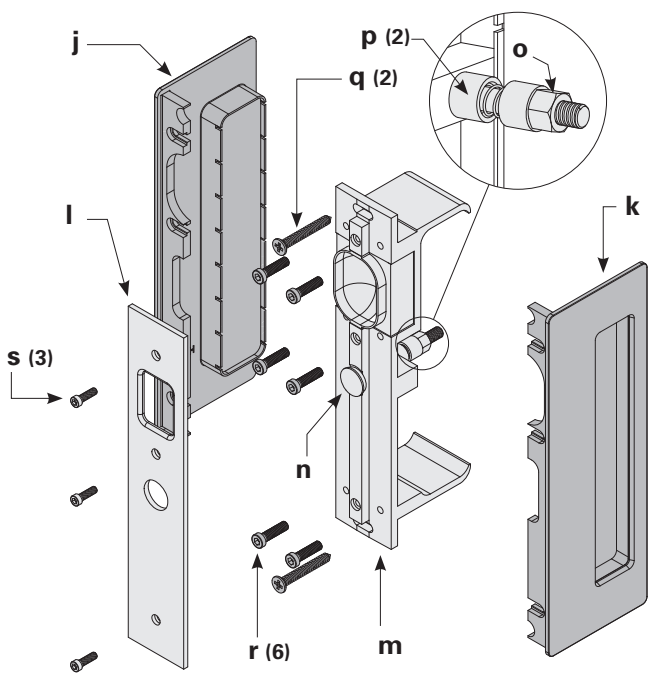

TOOLS (contained in Passage Chassis Box)

- t** Plunger Adjustment Spanners (2)

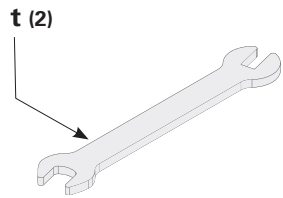

Fitting the Passage Handle

8. Remove the *passage chassis* from its packaging. Remove the *face plate screw* and *face plate* from the chassis.

Align the chassis with the centre of the door thickness. Screw the chassis to the door (using the two *chassis mounting screws*) through the slotted holes at the top and bottom of the chassis. **DO NOT** fully tighten the screws.

Realign the chassis with the centre of the door thickness. When happy with the chassis position, fully tighten the screws.

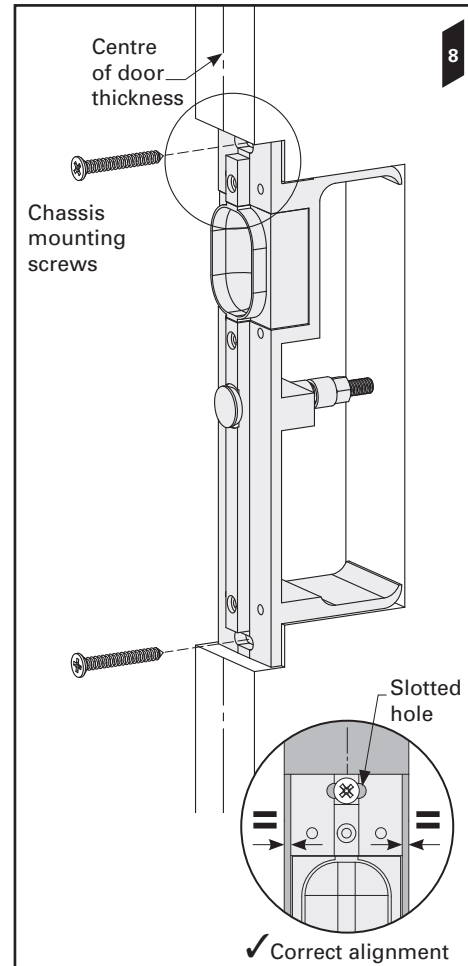

9. Fit the 6x *side handle* to *chassis screws*. Leave a **3mm gap** (1/8") between the underside of the screw head and the chassis.

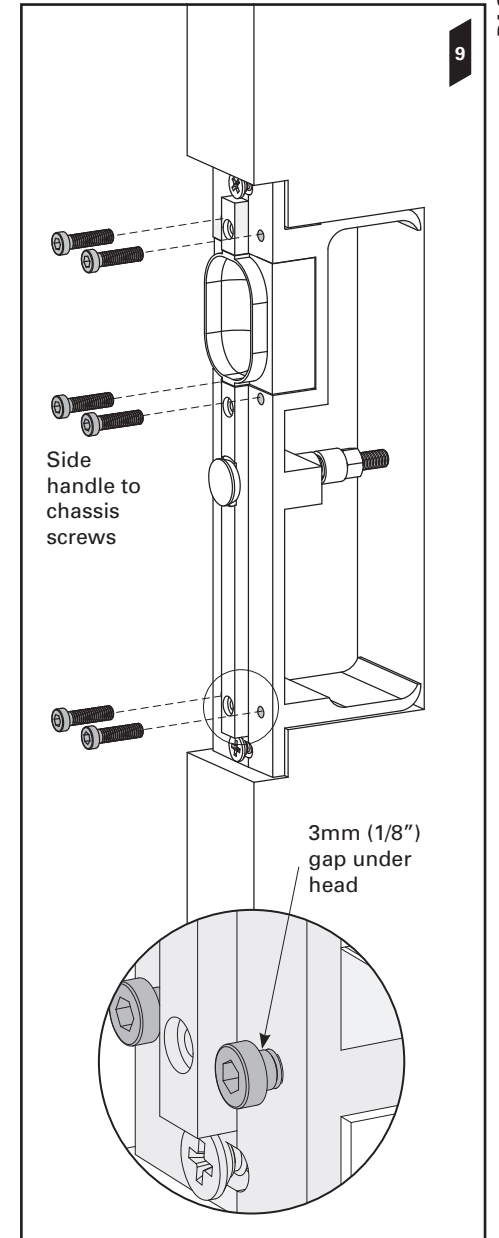

Fitting the Passage Handle

10. Fit one of the *passage side handles* (left **OR** right) to the chassis by sliding the front flange of the handle under the heads of the 3x *side handle to chassis screws*. Tighten the screws.

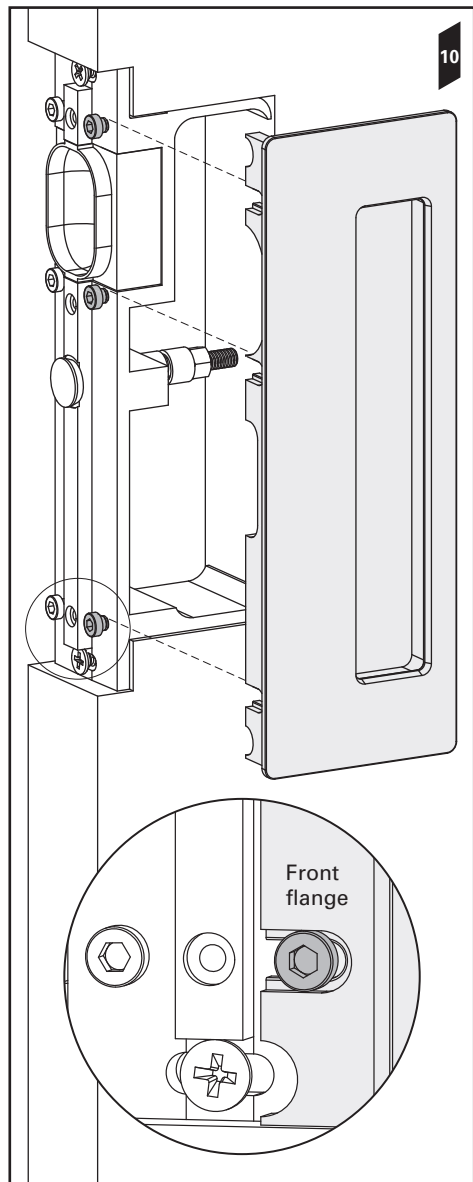

Adjusting the Plunger

11. Manually push the *plunger* in the passage chassis forward until there is no gap between *spring reservoir one* (SR1) and *spring reservoir two* (SR2).

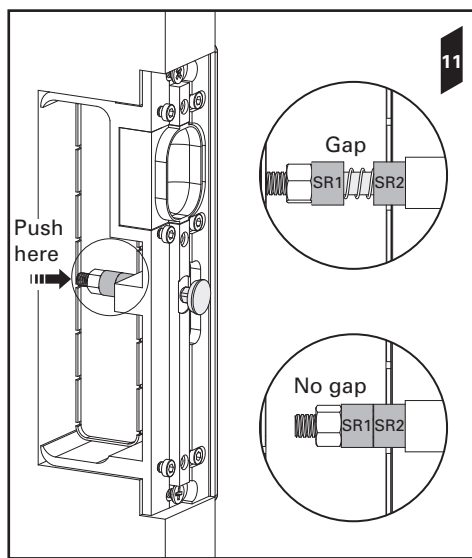

12. Two identical spanners have been supplied. Restrain the *plunger nut* using the **large** end of one of the supplied *spanners*. Place the **small** end of the second spanner across the flats under the head of the plunger. Keep the spanner restraining the plunger nut **stationary** while turning the second spanner **clockwise**.

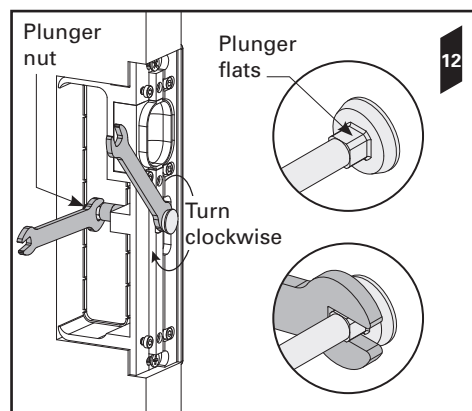

Adjusting the Plunger

13. Continue to turn the spanner until there is no longer a gap between the spanner and the chassis. Now turn the spanner **anti clockwise** half a turn. The plunger should now be adjusted correctly. Slide the doors closed and check that they latch. Adjust if necessary.

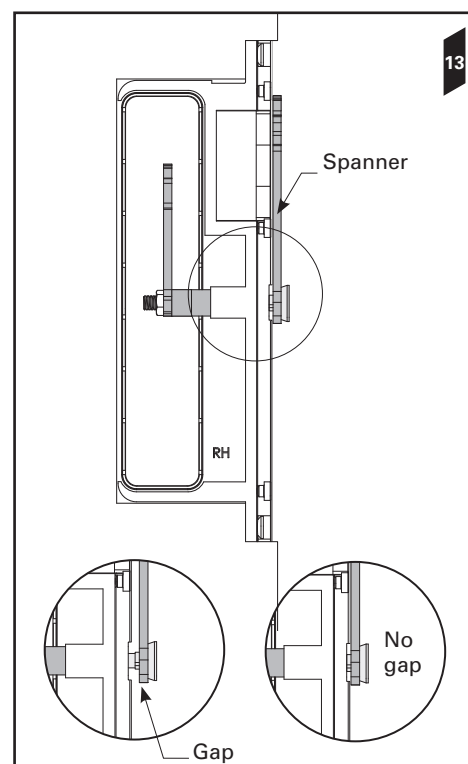

Fitting the Remaining Side Handle

14. Fit the remaining side handle to the chassis (using the three remaining *side handle to chassis screws*) by sliding the front flange of the handle under the heads of the three screws. Tighten the screws.

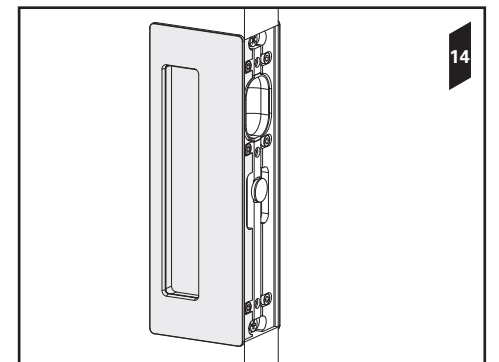

15. Fit the *passage face plate* to the chassis using the 3x *handle face plate screws*.

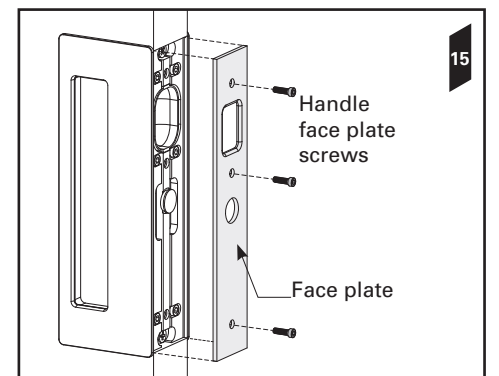

© Cavity Sliders Limited. CAVILOCK® CL400® MAGNETIC (O.D. 2013) PASSAGE BIPARTING INSTRUCTIONS. 60911/CL400ZA922 - 10.2014
All copyright and other property in this document is reserved by Cavity Sliders Limited. Details and specifications are subject to change without notice. Whilst all care is taken to ensure the accuracy of all information, no responsibility will be accepted for any errors or omissions. © CS FOR DOORS, CS CAVITY SLIDERS and CAVILOCK are Registered Trademarks. Patents pending.



Handles & locks for sliding doors



www.csfordoors.co.nz
www.cavitysliders.com.au
www.cavilock.com

Cavity Sliders Limited
Auckland Head Office
5 - 7 Rakino Way
Mt Wellington
Auckland, NZ

T +64 9 276 0800
F +64 9 276 2525
info@csfordoors.co.nz