

There are three stages to fitting the CL100 mortice case:

Stage 1: Mark out the position of the lock.

Stage 2: Prepare the door by morticing and drilling holes.

Stage 3: Fit lock, door furniture, cylinder, striker, etc.

**Stage 1:
Mark out the position of the lock (use a sharp nail to mark hole centres).**

- A: Mark the chosen height of the lock on the face of the door. The height is normally measured to the centre of the square spindle (**Hole 1**) or if a CL100 which does not require a square spindle is to be fitted (e.g. Slamshut), the height should be taken to the centre of the top Europrofile cylinder hole (**Hole 6**) (Diagram A).
- B: Mark the 'Height Line' 61mm (2-13/32") above **Hole 1** or 125mm (4-15/16") above **Hole 6** on to the edge and face of the door (Diagram A).
- C: Mark a vertical 'Centre Line' onto the edge of the door as shown (Diagram A).
- D: Hold the Drilling Template onto the edge of the door aligning the top edge of the Template with the 'Height Line', and the arrows on the Template with the 'Centre Line'. Mark the hole centres for the 6 x 19mm (3/4") diameter holes (**Holes 8 to 13**) and the two screw holes (**Holes 14 & 15**) (Diagram A).
- E: Fold the Template as shown and wrap it around the door edge and face with the top of the Template level with the 'Height Line'. Mark out the holes as determined by 'Hole Drilling Options' on the back of the Template (Diagram B).

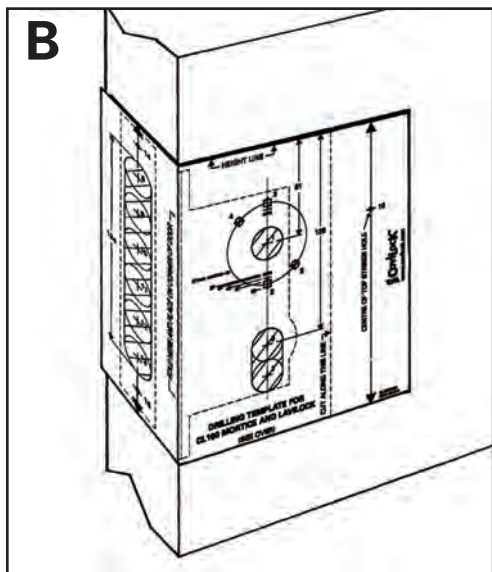
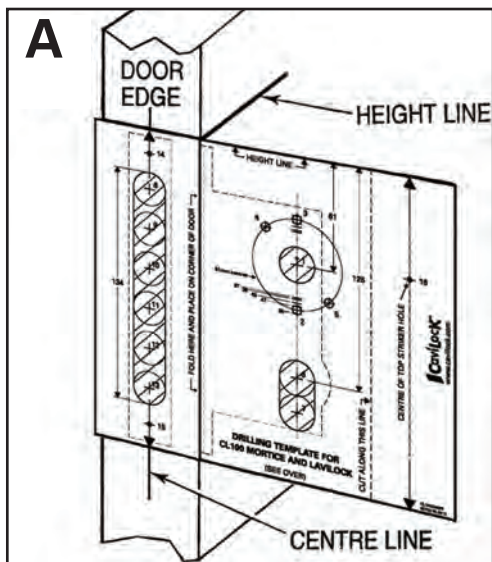

Stage 2:

Prepare the door (read in conjunction with 'Hole Drilling Options' on back of Template).

- A: Using a 19mm (3/4") diameter drill bit, drill **Holes 8 to 13** to a depth of 77mm (3-1/16") (use a felt tip pen or tape to mark hole depth on the drill bit). Make sure the drilled holes are straight and level. Chisel out the remaining wood between the holes as indicated by the shaded area on the Template and clean out the hole.

Note: Maximum slot length not to exceed 134mm (5-9/32").

- B: Remove the faceplate and fit the lockcase into the morticed hole. Temporarily screw the lock into place using woodscrews through the two pre-drilled holes (**Holes 14 & 15**). Make sure the inner forend lies parallel with the edge of the door.

Mark around the inner forend then remove the lock.

Router out to a depth of 7mm (9/32") (Diagram C).

Important: This recess to take the front section of the lock must be routed out flat and even. Failure to do so may cause long term damage to the lock.

- C: Drill the cross holes (e.g. spindle) as previously marked.
- D: Chisel out the remaining wood to form the oval shape slot between **Holes 6 & 7**.

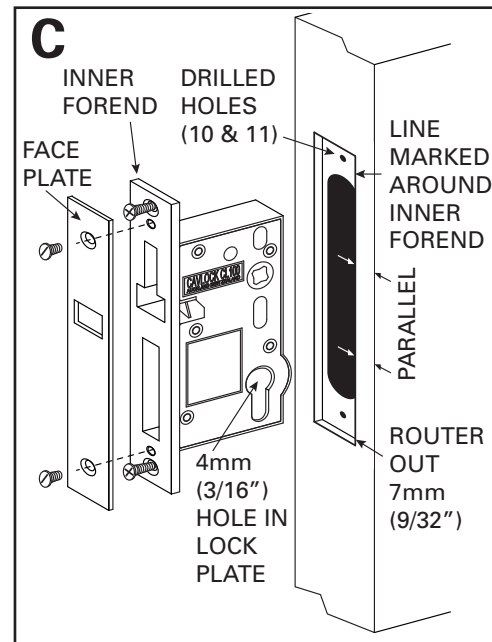

STAGE 3:

Fitting LaviLock Only

- A: Fit the lock into the mortice and screw into place using the #10 countersunk screws supplied.
- B: Refit the faceplate.
- C: Cut the 4mm (5/32") diameter x 50mm (2") long locking pin to the same length as the door thickness, de-burr the end and slide it into the 4mm (5/32") hole in the lock plate (Diagram D).

Stage 3 continued overleaf

IMPORTANT: THE CL100 IS NOT A DOOR STOP.

A hinged door is stopped in the correct closed position by the door stop, NOT the lock. The same applies to a sliding door. If the door's momentum is not stopped by a closing jamb or an independent stop, long term damage may be done to the lock. To avoid this, make sure that the door hits the jamb or stop at the same time that the striker bottoms out on the faceplate of the lock.

(LaviLock Only) Fit either:

Option A: Locking button inside, emergency release button outside.

Option B: Locking buttons inside and outside.

Do not forget to put the 4mm (5/32") diameter spring(s) into the locking button(s).

Note: Option A is the normal configuration, however Option B can be used where "Quick Emergency" access is required to a room, e.g. a toilet in a resthome.

- D: Place the indicator plates one each side of the door, over the buttons as shown (the unlock / lock indicator plate goes to the inside of the room).
- E: While holding the indicator plates in place, slide the 7.62mm (5/16") square spindles into the lock.
Fit the chosen lever handles (you may need to cut the spindle and screws to length first). Check that the handing of the handles is the correct way around and only tighten the screws enough to hold the handles and indicator plates onto the door.
- F: Test the lock for the following:
- That the handles move freely.
 - That the latch returns to the latched position once the handles are let go.
 - That the locking button(s) move up and down freely without jamming.
 - That the indicator plates are parallel with the edge of the door.
- G: When the testing is complete, fully tighten the screws holding the lever handles, and follow instructions for 'LaviLock' under 'Hole Drilling Options' on back of Template.
- H: Slide the door closed and transfer the height line from the door onto the closing jamb. Cut out the Template where marked and align the top of it with the height line. Mark the top screw hole, making sure that it is in the centre of the closing jamb (use the centre line that is marked on the Template).

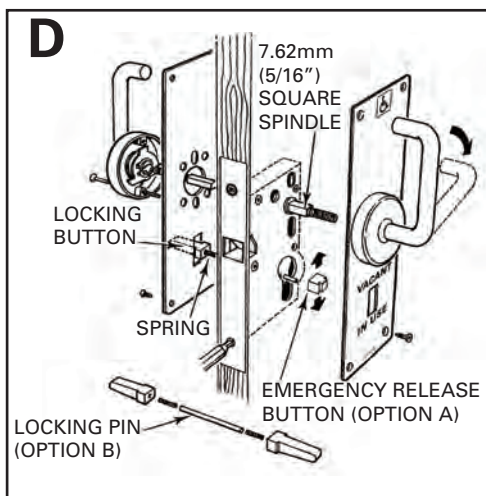

Fit the striker using the top screw only. Close the door slowly to check that the striker lines up with the lock, adjust if necessary then fit the bottom screw. On timber jambs you may mortise the back of the striker into the closing jamb to a depth of 3mm (1/8") (Diagram E).

STAGE 3: Fitting Lock (Lever or Flushturn)

- A: Fit the lock into the mortice and screw in place using the #10 countersunk screws supplied.
- B: Slide the 7.62mm (5/16") square spindle into the lock (if required) and fit the chosen handles (you may need to cut the spindle and screws to length first).
- C: Slide the Europrofile cylinder (if required) into the hole until the tapped hole in the cylinder lines up with the corresponding hole in the lock case.
Fix the cylinder into place with the cap screw supplied (access to the hole is through the long slot in the inner forend). Tighten the cap screw firmly and then fit faceplate to forend.

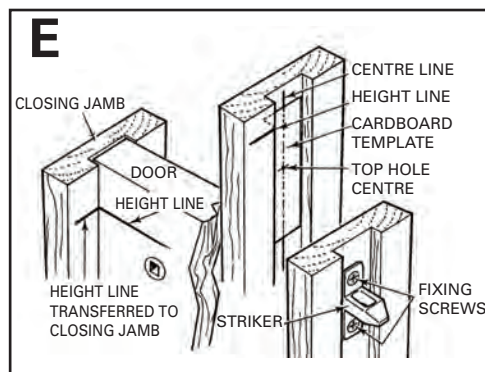

- D: Test the lock for the following:
- That the handles move freely.
 - That the latch returns to the latched position once the handles are let go.
- E: Fit the escutcheons around the cylinder.
- F: Slide the door closed and transfer the height line from the door onto the closing jamb. Cut out the template where marked and align the top of it with the height line.

Ensure the striker is facing right way up with the slotted screw hole to the top (Diagram F).

Mark the top screw hole, making sure that it is in the centre of the closing jamb (use the centre line that is marked on the Template).

Fit the striker using the top screw only, close the door slowly to check that the striker lines up with the lock, adjust if necessary then fit the bottom screw.
On timber jambs you may mortise the back of the striker into the closing jamb to a depth of 3mm (1/8").

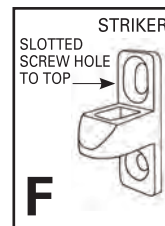

© All copyright and other property in this document is reserved by Cavity Sliders Limited. Details and specifications are subject to change without notice. Whilst all care is taken to ensure the accuracy of all information, no responsibility will be accepted for any errors or omissions.
© CS FOR DOORS and CAVILOCK are Registered Trademarks.
New Zealand Patent No: 533838.

CS CAVILOCK® (O.D. 1994). 03.2016 / CL100ZA520

FITTING INSTRUCTIONS for the CL100 Mortice Case

 **CL100™** LaviLock

 **CL100™** Lever

 **CL100™** FlushTurn

**Please read
instructions carefully
before starting**

 **CaviLock®**

Handles & locks for sliding doors