

NEED HELP?
Call or Email us first

Our service team is ready to answer your questions...
1-800-265-1833 (English) / 1-800-567-2513 (French)
IN CANADA - ressalescanada@canarmna.ca - IN USA - ressalesusa@canarmna.ca

Monday – Friday
8 AM - 5 PM EST.



INSTRUCTIONS PERTAINING TO RISK OF FIRE OR INJURY TO PERSONS
READ ALL INSTRUCTIONS

IMPORTANT SAFETY INSTRUCTIONS SAVE THESE INSTRUCTIONS

TOOLS AND MATERIALS REQUIRED:



Phillips
Screwdriver



Wire Cutters



Pliers



Wrench

Wiring supplies
as required by
local electrical
code

SAFETY PRECAUTIONS:

1. TURN OFF ELECTRICAL POWER BEFORE STARTING INSTALLATION OF LIGHT FIXTURE.
2. THIS PRODUCT MUST BE INSTALLED IN ACCORDANCE WITH THE APPLICABLE INSTALLATION CODE BY A PERSON FAMILIAR WITH THE CONSTRUCTION AND OPERATION OF THE PRODUCT AND THE HAZARDS INVOLVED.
3. CAUTION – RISK OF FIRE. CONSULT A QUALIFIED ELECTRICIAN TO ENSURE CORRECT BRANCH CIRCUIT CONDUCTOR.
4. CONNECT THE GROUND WIRES (BARE COPPER OR GREEN) FROM YOUR FIXTURE TO THE GROUND WIRE (BARE COPPER OR GREEN) OR GROUND SCREW IN THE ELECTRICAL BOX.
5. TO CLEAN THE FIXTURE, TURN OFF THE POWER. WAIT FOR IT TO COOL. WIPE THE OUTSIDE SURFACE OF FIXTURE WITH A CLEAN, DRY AND SOFT CLOTH. NO SERVICE PART IS REQUIRED INSIDE THE FIXTURE.

NOTE: Product may not look exactly as shown in figures.

INSTALLATION:

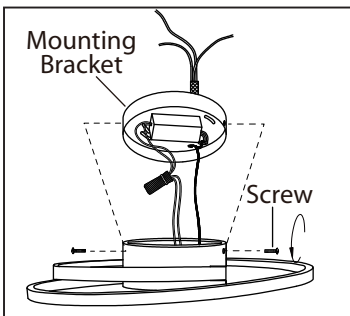

1. Remove the mounting bracket from the fixture by unscrewing the 2 screws.

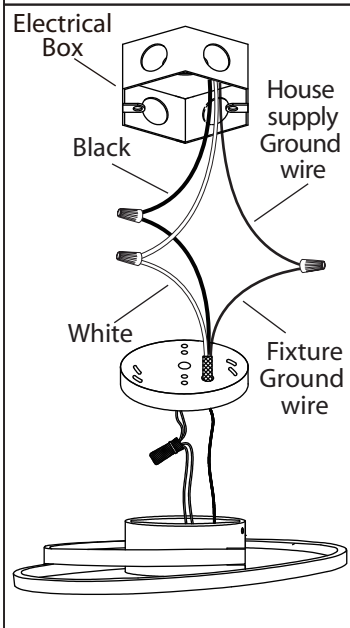

2. Connect the ground wire (bare copper or green) from your fixture to the ground wire (bare copper or green) or ground screw in the electrical box. Attach the black wire from the light fixture to the black wire in the electrical box. Attach the white wire from the light fixture to the white wire in the electrical box.

NOTE: Do not disconnect any pre-wired connections.

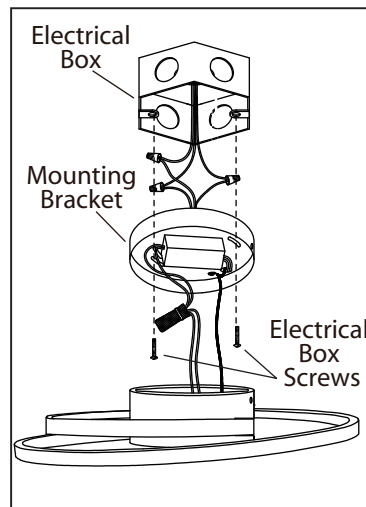

3. Mount the mounting bracket to electrical box using electrical box screws (not included).

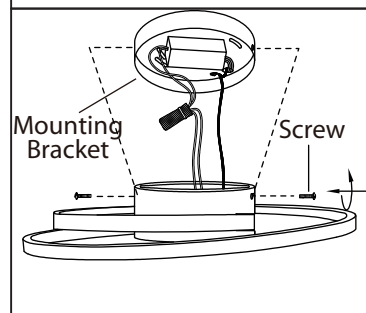

4. Once connections of wires are completed, carefully tuck wires and wire nuts into the electrical box making sure no bare wire (on the black and white) is visible at the wire nuts.

5. Re-tighten the two screws to install the fixture.



dimnable

This LED light is compatible with the dimmers:
LEVITON# 742-6672-HLW, 722-6674-PDW MAX 150 W,
Lutron # SCL-153PH-WH MAX 150 W.
The MAX rated wattage of this model is 25 W