

# LED CHANDELIER

**NEED HELP?**  
Call or Email us first

Our service team is ready to answer your questions...  
1-800-265-1833 (English) / 1-800-567-2513 (French)  
IN CANADA - ressaiescanada@canarmna.ca - IN USA - ressaiesusa@canarmna.ca

Monday – Friday  
8 AM - 5 PM EST.



INSTRUCTIONS PERTAINING TO RISK OF FIRE OR INJURY TO PERSONS  
READ ALL INSTRUCTIONS

## IMPORTANT SAFETY INSTRUCTIONS SAVE THESE INSTRUCTIONS

### TOOLS AND MATERIALS REQUIRED:



Phillips  
Screwdriver



Wire Cutters



Pliers



Wrench

Wiring supplies  
as required by  
local electrical  
code

### SAFETY PRECAUTIONS:

1. TURN OFF ELECTRICAL POWER BEFORE STARTING INSTALLATION OF LIGHT FIXTURE.
2. THIS PRODUCT MUST BE INSTALLED IN ACCORDANCE WITH THE APPLICABLE INSTALLATION CODE BY A PERSON FAMILIAR WITH THE CONSTRUCTION AND OPERATION OF THE PRODUCT AND THE HAZARDS INVOLVED.
3. CONNECT THE GROUND WIRES (BARE COPPER OR GREEN) FROM YOUR FIXTURE TO THE GROUND WIRE (BARE COPPER OR GREEN) OR GROUND SCREW IN THE ELECTRICAL BOX.
4. TO CLEAN THE FIXTURE, TURN OFF THE POWER, WAIT FOR IT TO COOL, AND WIPE THE FIXTURE WITH A CLEAN, SOFT CLOTH.

**NOTE:** Product may not look exactly as shown in figures.

### INSTALLATION:

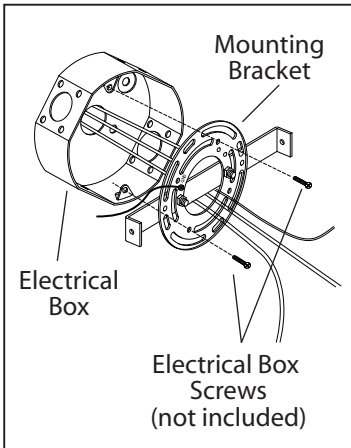

**1.** Mount the mounting bracket to electrical box using electrical box screws (not included).

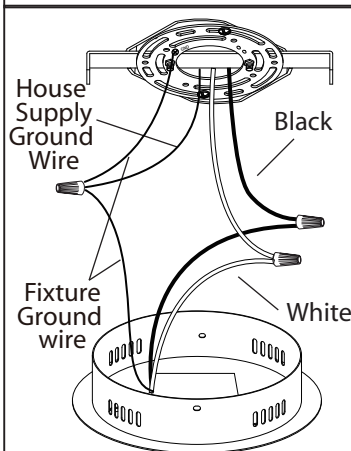

**2.** Connect the ground wires (bare copper or green) from your fixture to the ground wire (bare copper or green) or ground screw in the electrical box. Connect the black wire from the fixture to the black wire in the electrical box and connect the white wire from the fixture to the white wire in the electrical box.

**NOTE:** Do not disconnect any pre-wired connections.

**3.** Once connections of wires are completed, carefully tuck wires and wire nuts into the outlet box making sure no bare wire is visible at the wire nuts.

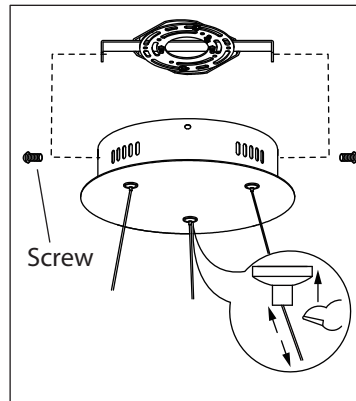

**4.** Attach fixture to mounting bracket by tightening the 2 screws.

**5.** Adjust the height of the fixture by pushing the button.

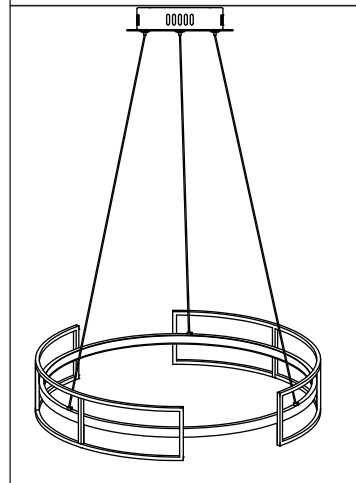

dimmmable

This LED light is compatible with the dimmers:  
LEVITON# 742-6672-HLW , 722-6674-PDW MAX 150 W, Lutron # SCL-153PH-WH MAX 150 W.  
The MAX rated wattage of this model is 33 W