

EASY CONNECT® INSTALLATION INSTRUCTIONS

IVL677A03
09/16

QUESTIONS OR CONCERNS CONTACT AT:
1-800-265-1833 (English) • 1-800-567-2513 (French)
Monday through Friday 8:00 AM to 5:00 PM E.S.T.



SAFETY PRECAUTIONS:

1. TURN OFF ELECTRICAL POWER BEFORE STARTING INSTALLATION OF LIGHT FIXTURE.
2. WIRING SUPPLIES AS REQUIRED BY LOCAL ELECTRICAL CODE.
3. THIS PRODUCT MUST BE INSTALLED IN ACCORDANCE WITH THE APPLICABLE INSTALLATION CODE BY A PERSON FAMILIAR WITH THE CONSTRUCTION AND OPERATION OF THE PRODUCT AND THE HAZARDS INVOLVED.
4. TO CLEAN THE FIXTURE, TURN OFF THE POWER, WAIT FOR IT TO COOL, AND WIPE THE FIXTURE WITH A CLEAN, SOFT CLOTH.

NOTE: Product may not look exactly as shown in figures.

INSTALLATION:

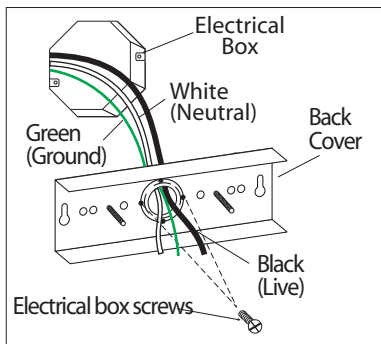

1. Feed power cords from the electrical box through the centre hole of the back cover. Align holes of back cover over electrical box and secure with electrical box screws (not included).

NOTE: Make sure the back cover is level before tightening the screws.

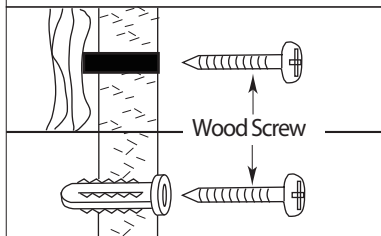

2. Additional support may be required for fixtures longer than 20". Position the fixture and add wood screws (one on each side) for the wooden studs or plastic wall anchor and wood screws for dry wall.

Option 1

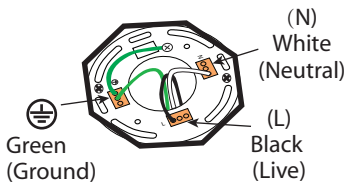

3. **Option 1:** Connect (push) electrical wires from electric box (house wiring) into correct inserts.

Option 2

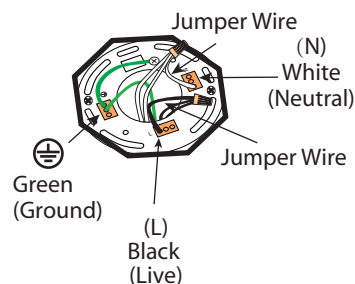

- Option 2:** For multiple black (live) & white (neutral) wires joined in the electrical box (house wiring), attach a single "black" and "white" Jumper Wire before connecting. Strip 7mm from a 6" Jumper Wires (AWG 12-24) supplied. Then connect (push) wires into correct inserts.

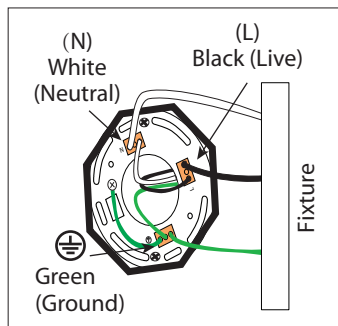

4. Connect (push) electrical wires from fixture into correct inserts.

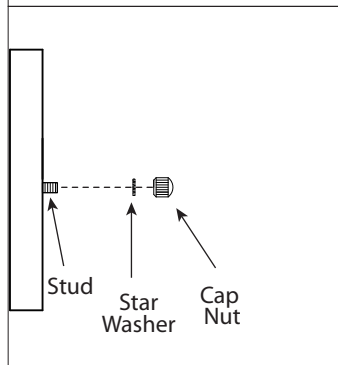

5. Tuck electrical wires into electrical box and position fixture over studs on mounting bracket assembly. Secure fixture in place with star washers and cap nuts.

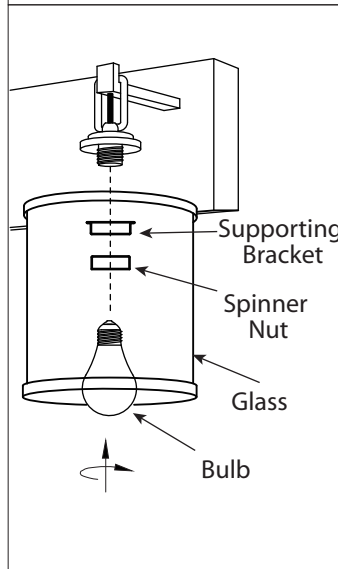

6. Remove spinner nut and support bracket from socket. Position glass on lamp and secure with spinner nut and support bracket.

7. Install proper bulb type and wattage (not included).