

# PB - R

## ½” Pressure Balance Valve Rough Installation Instructions

**CALIFORNIA FAUCETS RECOMMENDS THAT ALL PLUMBING PRODUCTS BE INSTALLED BY A LICENSED PROFESSIONAL**

**IMPORTANT:** Read all instructions prior to installation and provide copy of instructions to consumer.

**WARNING:** This valve is factory set to deliver water at the highest temperature possible. It is the installer’s responsibility to properly set the desired and/or required maximum temperature setting to prevent risk on scalding or other severe injury prior to consumer use. The installer is responsible for adjusting maximum temperature setting according to TO-PBL-XX ½” Pressure Balance Trim Installation Instructions.

**Operating Specifications:**

Recommended Supply Pressure:	20 to 70 psi*†
Recommended Hot Water Supply Temperature:	120 to 140°F‡
Nominal Flow Rate @ 60 psi:	5.0 gpm (tub outlet)
	4.2 gpm (shower outlet)

\* Operating pressures between hot and cold supplies should vary no more than 5 psi.  
 † If water pressure exceeds 70 psi, install a Pressure-Reducing Valve (RPV).  
 ‡ Follow all applicable local plumbing codes when setting the temperature on valve and water heater.

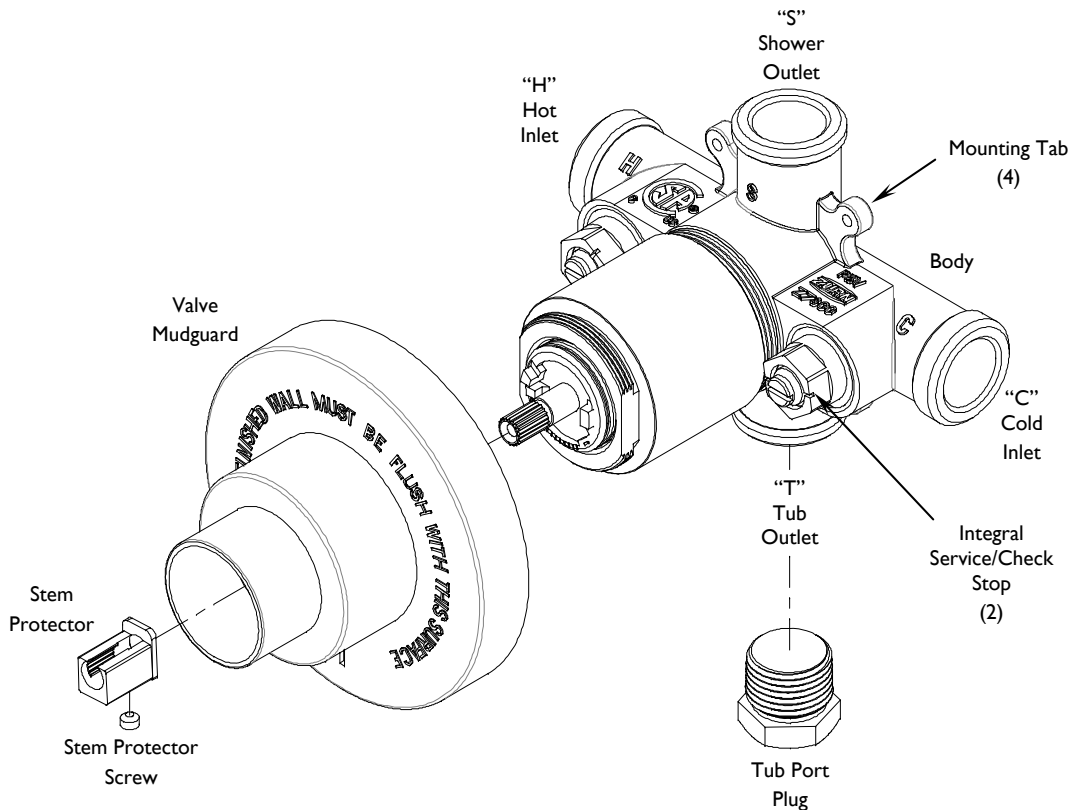
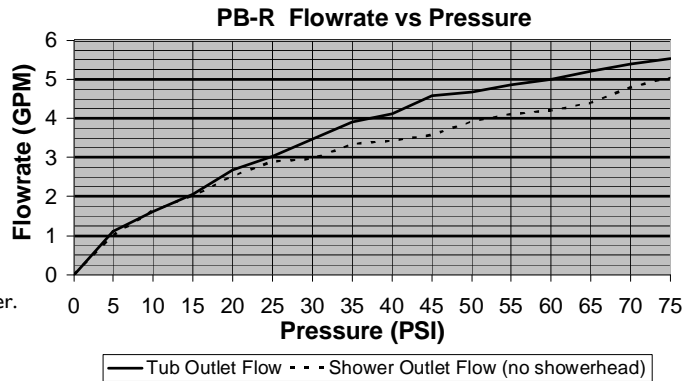

California Faucets®

## 1 INSTALLING VALVE TO FRAME

- Determine the desired location for the valve, construct suitable stud, and support framing
- Attach VALVE (1) to CROSS SUPPORT (2) by using SCREWS (3) (not supplied) as shown
- The valve should be level in HORIZONTAL, VERTICAL and PARALLEL to wall
- Placement of VALVE (1) and CROSS SUPPORT (2) within the wall shall be determined by the MIN/MAX limits shown on MUDGUARD (4)
- For complete detailed VALVE (1) dimensions and recommended placement see **5 ROUGH-IN DIMENSIONS**

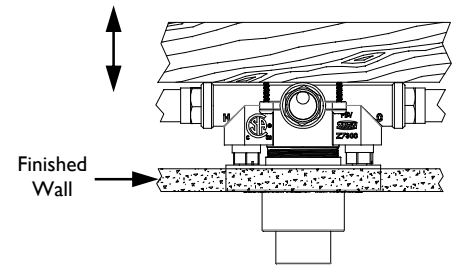

## 2 WATER CONNECTIONS

- Pre-assemble FITTINGS (5) prior to attaching to VALVE (1)
- Attach “C” INLET to COLD SUPPLY and “H” INLET to HOT SUPPLY. **All soldering of FITTINGS (5) shall be performed a minimum of 4” away from VALVE (1)**
- Attach TUB PIPE (6a) to “T” OUTLET. **Do not use PEX or CPVC CTS piping from valve to tub spout, as the reduced ID will result in too much back pressure for valve to function properly**
- If valve is installed for SHOWER ONLY configuration, attach PLUG (6b) to “T” OUTLET
- Attach SHOWER PIPE (7) to “S” OUTLET
- For additional support, use PIPE CLAMP (8) and SCREW (3) (not supplied) at all attached pipe connections

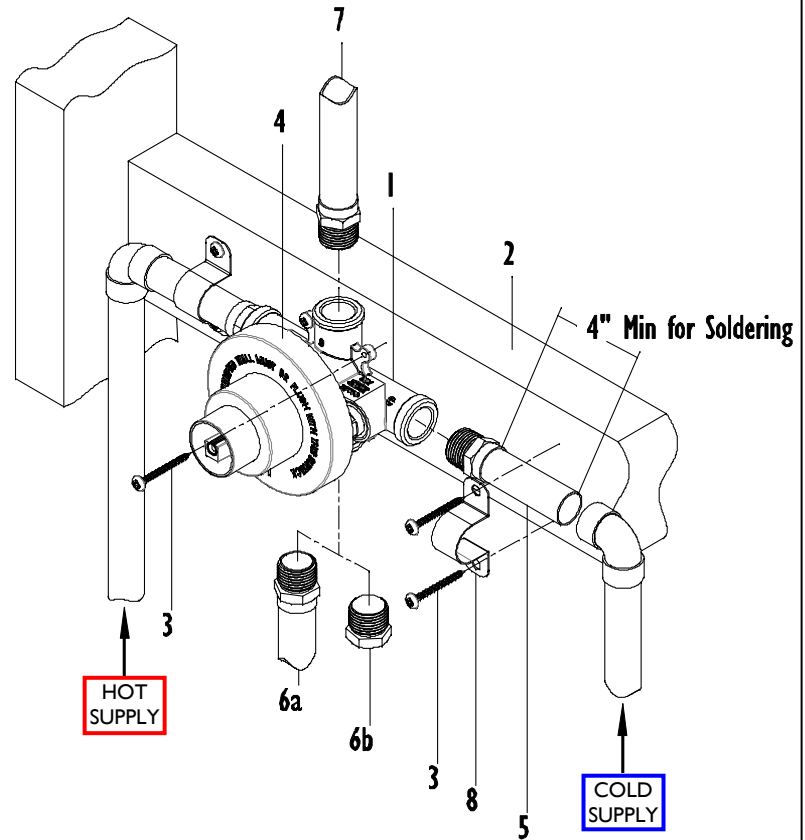

**IMPORTANT:** Flush supply lines prior to installation to prevent damage and malfunction of pressure balance cartridge

**IMPORTANT:** If Cold and Hot supplies are not easily attachable to desired inlet ports or for “Back-to-Back” installations, see **4 MAINTENANCE**

**CAUTION:** This valve contains plastic and rubber components. Do not sweat or braze directly to the valve body. Do not apply excessive heat to the valve body when you make solder connections. Do not apply flux or acids directly to the valve, as damage to the seals, plastic components, and trim finish may result

**CAUTION:** Inlet and outlet threaded joint connections should be made with plumbers PTFE tape or liquid sealant. Oil-based, non-setting compounds should not be used

### 3 FINISHED WALL

- VALVE (1) shall be located in framed wall so that FINISHED WALL (9) is FLUSH with surface of MUDGUARD (4)
- The Maximum GAP between FINISHED WALL (9) and MUDGUARD (4) should be no more than 1/4" to allow for proper trim coverage
- These finished wall requirements are necessary for proper fit of trim as described in TO-PBL-XX 1/2" Pressure Balance Trim Installation Instructions

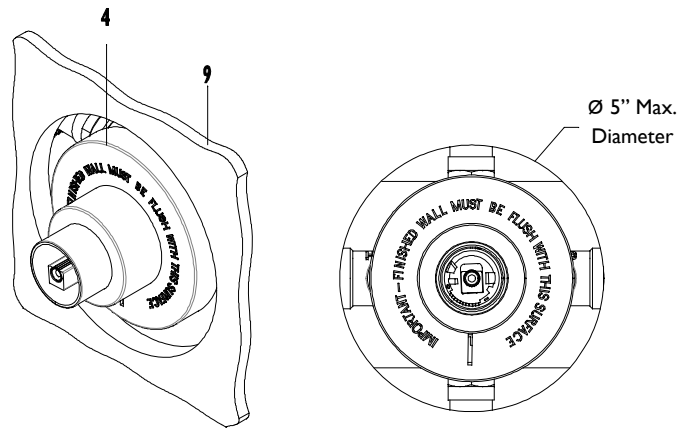

### 4 MAINTENANCE

#### Pressure Balance Cartridge Service

- Shut off water supply to pressure balance cartridge by turning hot & cold SERVICE STOP SCREW (10) clockwise (inward) until screw stops
- Remove CARTRIDGE NUT (11) from BODY (1)
- Carefully remove CARTRIDGE (12) from BODY (1) by holding CARTRIDGE (12) as close to BODY (1) as possible and wiggle back and forth until CARTRIDGE (12) comes out

**IMPORTANT:** To prevent accidental disassembly of cartridge during removal, place finger and thumb on tabs of CARTRIDGE (12) as shown

- To determine if cartridge is functioning properly shake cartridge from side to side, the internal piston should make a clicking sound; if no sound perform the following: Soak cartridge in white vinegar for at least 8 hours to remove scale and debris; if still no clicking sound is heard replace cartridge

**IMPORTANT:** Prior to installing CARTRIDGE (12), apply a thin film of non-petroleum based grease onto O-RING (13)

- Tighten CARTRIDGE NUT (11) to 150 in-lbs
- Open hot & cold SERVICE STOP SCREW (10) counter-clockwise (outward) until screw stops

#### Reversed COLD and HOT Inlets

- Perform above steps to remove CARTRIDGE (12) from BODY (1), with CARTRIDGE (12) removed rotate cartridge 180° and slide back into BODY (1)

**CAUTION:** When inserting CARTRIDGE (12) be certain that top and bottom pins align into holes on BODY (1)

#### Check Valve Service

- Shut off water supply to valve inlets at main or valve upstream from BODY (1)
- Remove CHECK VALVE (15) from BODY (1)
- Rinse CHECK VALVE (15) under running water
- Prior to installing CHECK VALVE (15) into BODY (1), apply a thin film of non-petroleum based grease onto O-RING (16)
- Tighten CHECK VALVE (15) to 150 in-lbs

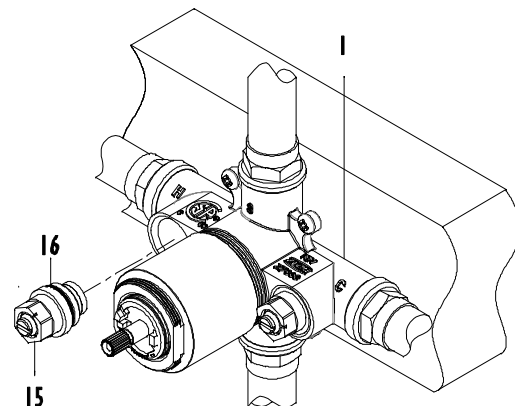
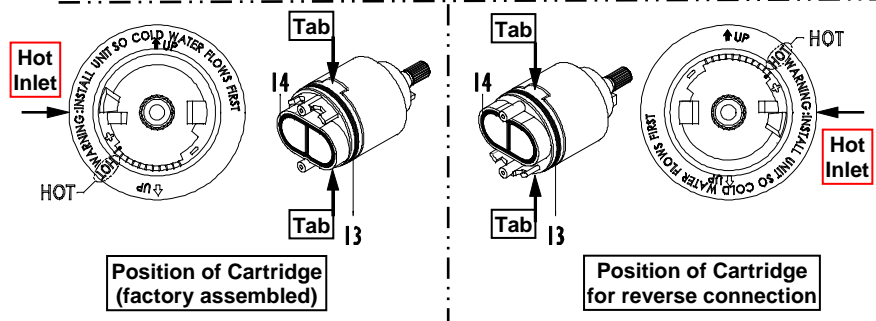
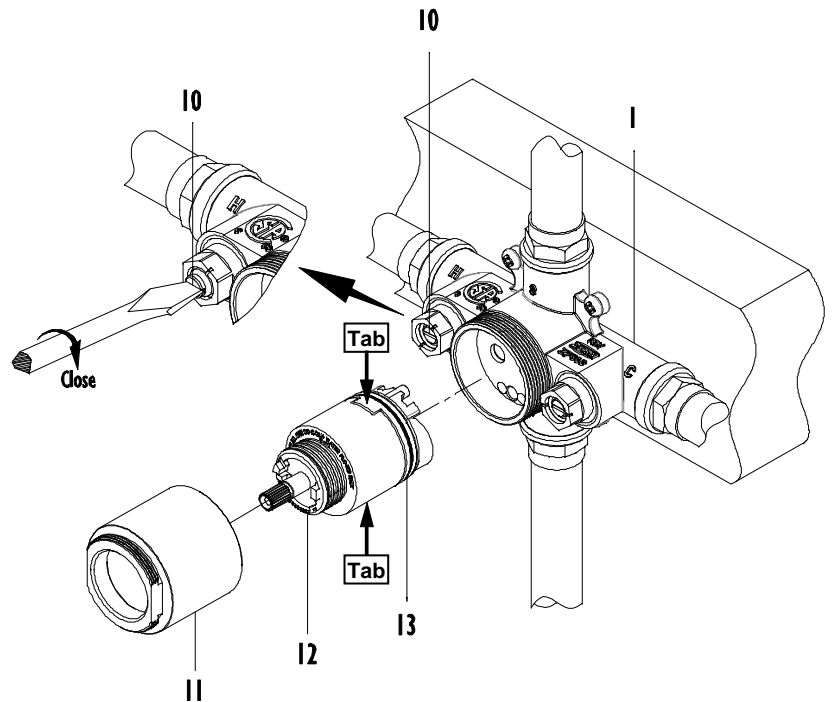

**ROUGH-IN DIMENSIONS**

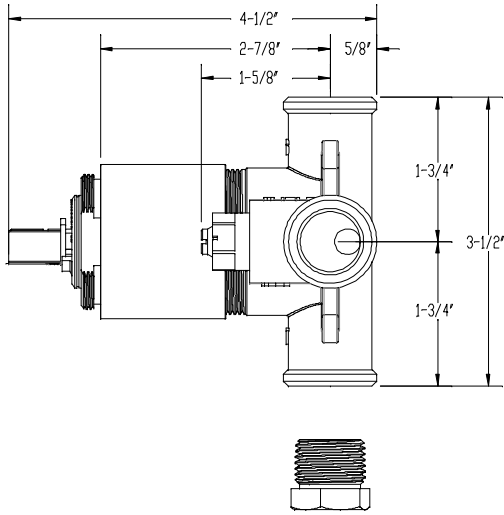

SIDE VIEW

FRONT VIEW

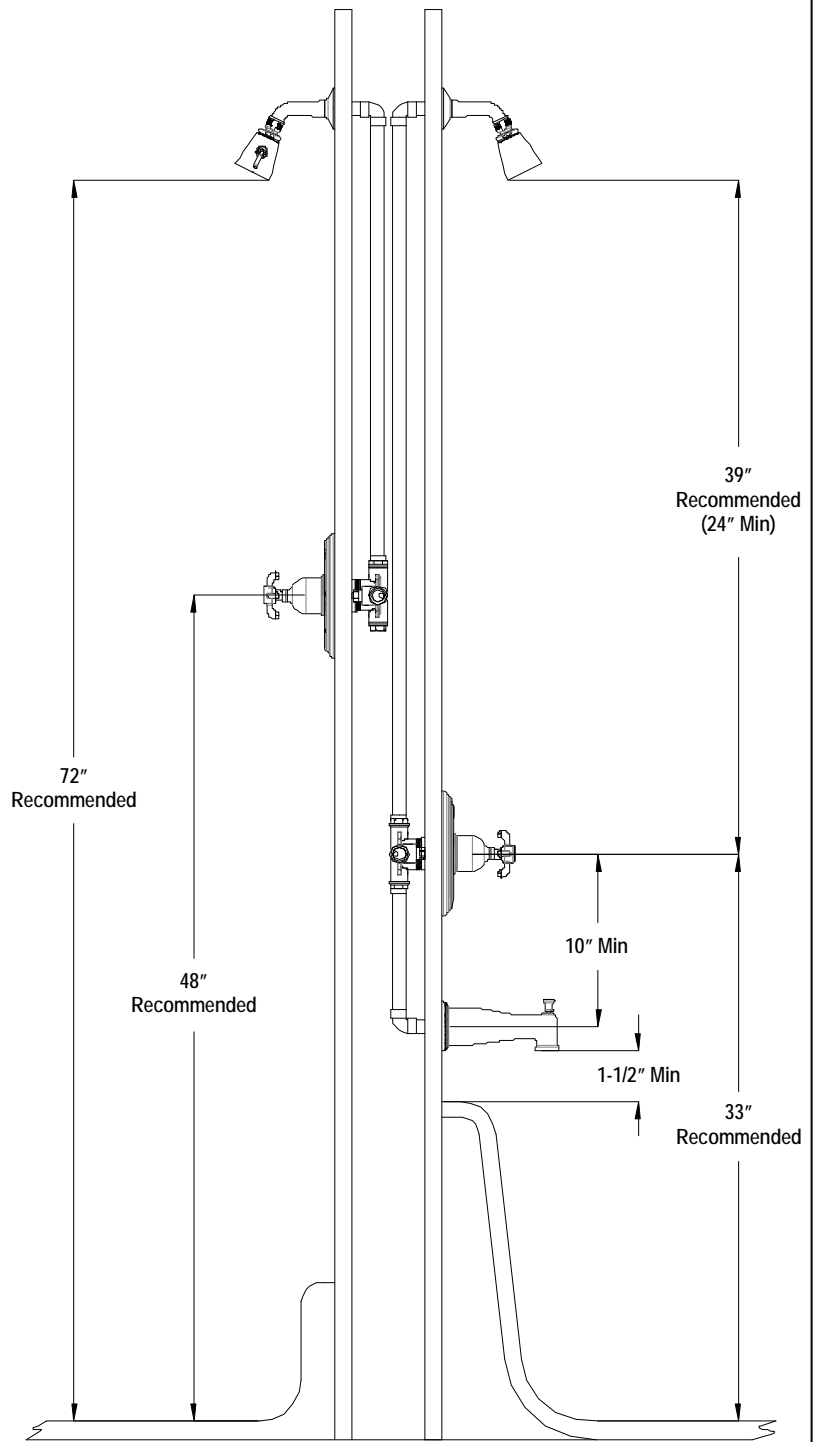
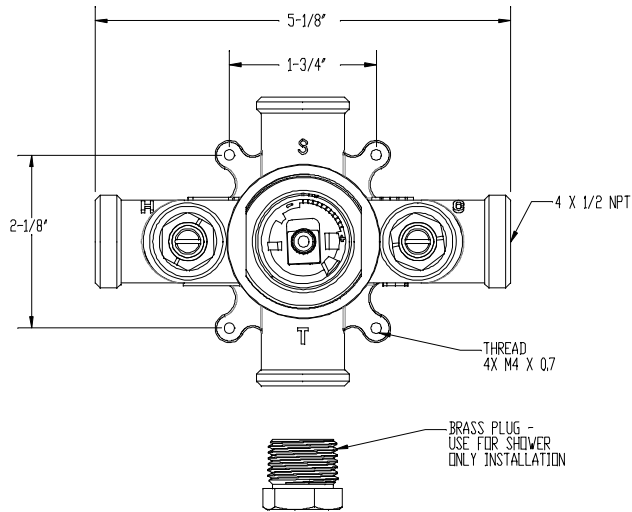

Recommended heights may vary based on user requirements

ALL DIMENSIONS SHOWN TO NEAREST 1/16"

[www.calfaucets.com](http://www.calfaucets.com)

5231 Argosy Ave. Huntington Beach, CA 92649

800-822-8855