

Product No. **BO-342-BS**

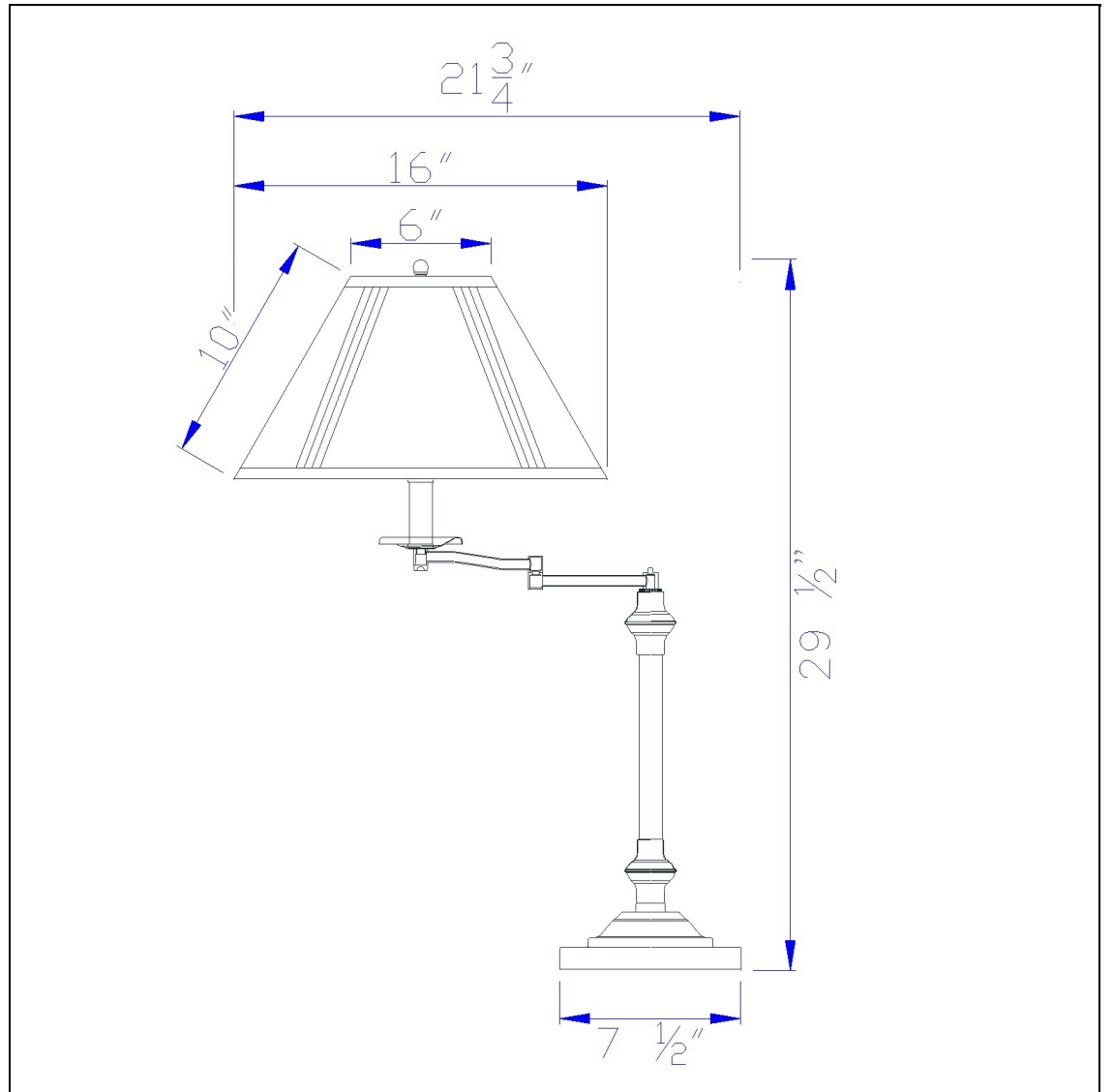

Description

150W 3 WAY SWING ARM TABLE LAMP
Durable metal construction
Fully functional swing arm
Little to no assembly required
Six foot power cord
Uses spider type shade
29.5" Height Metal Table Lamp in Brushed Steel

Technical Specifications

UPC	020193067284
Wattage	150W
Switch Type	3-Way
Bulb Base	E26
Number of Lights	1
Color	Brushed Steel
Base Color	Brushed Steel

Carton 1 Dimensions	8.50 x 20.50 x 20.50
Carton 2 Dimensions	0.00 x 0.00 x 20.50
Carton 3 Dimensions	18.00 x 18.00 x 12.00
Package Dimensions	L: 20.50 W: 20.50 H: 8.50