



VB0190

**Model ERV70S** (side ports)



VB0192

**Model ERV70T** (top ports)



VB0191

**Model HRV70SE\*** (side ports)



VB0193

**Model HRV70TE\*** (top ports)

**READ AND SAVE THESE INSTRUCTIONS  
INSTALLER: LEAVE THIS MANUAL WITH HOMEOWNER**

Register your product online at: [www.broan.com/register](http://www.broan.com/register)



7 72371 12787 6



\* These products earned the ENERGY STAR® by meeting strict energy efficiency guidelines set by Natural Resources Canada and the US EPA. They meet ENERGY STAR requirements only when used in Canada.

## **Congratulations!**

You have made an excellent choice! The operating principle of your Heat Recovery Ventilator or your Energy Recovery Ventilator will give you personal comfort you have never known before.

We have prepared this User Guide especially for you. Please read it carefully to ensure you obtain full benefit from your unit. Over the coming months, you will increasingly appreciate the feeling of living in a more comfortable house.

Please take note that this manual uses the following symbols to emphasize particular information:

### **⚠ WARNING**

**Identifies an instruction which, if not followed, might cause serious personal injuries including possibility of death.**

### **CAUTION**

**Identifies an instruction which, if not followed, may severely damage the unit and/or its components.**

NOTE: Indicates supplementary information needed to fully complete an instruction.

We welcome any suggestions you may have concerning this guide and/or the unit, or ways to better serve you. Please forward all correspondence at the address below:

Broan-NuTone LLC  
Indoor Air Quality Mkt.  
926 W. State St.,  
Hartford, WI 53027

### **CAUTION**

**Make sure at all times that the outside intake and exhaust hoods are free from any snow during the winter season. It is important to check your unit during a big snow storm, so it doesn't draw in any snow. If this is the case, please operate the unit in recirculation mode, or turn it OFF for a few hours. Do not use your unit during construction or renovation of your house or when sanding drywall. This type of dust may damage your system. Since the electronic control system of the unit is incorporated with a microprocessor, it may not operate correctly because of external noise or very short power failure. If this happens, unplug the unit and wait approximately 10 seconds. Then, plug the unit in again.**

---

---

# TABLE OF CONTENTS

---

---

<b>1. DEFROSTING MODE</b>	<b>3</b>
<b>2. CONTROLS</b>	<b>4-6</b>
2.1 INTEGRATED CONTROL	4
2.2 OPTIONAL MAIN CONTROL VT4W	5
2.3 OPTIONAL AUXILIARY CONTROLS	6
2.3.1 20-MINUTE LIGHTED PUSH BUTTON	6
2.3.2 60-MINUTE CRANK TIMER	6
2.3.3 DEHUMIDISTAT	6
<b>3. MAINTENANCE</b>	<b>7-9</b>
3.1 QUARTERLY MAINTENANCE	9
3.2 ANNUAL MAINTENANCE	9
<b>4. TROUBLESHOOTING</b>	<b>9-10</b>

## 1. DEFROSTING MODE

---

---

When the outside temperature is below 23°F (-5°C), recovery of heat or energy creates frost in the core.

To maintain its proper operation, the unit is programmed to defrost the recovery core. The defrost frequency varies according to the outside temperature.

During the defrost cycle, the unit shifts to maximum speed and the dampers close.

After defrosting, the unit returns to the operating mode selected by the user.

## 2. CONTROLS

### 2.1 INTEGRATED CONTROL

#### **BOOTING SEQUENCE**

The unit booting sequence is similar to a personal computer boot sequence. Each time the unit is plugged after being unplugged, or after a power failure, the unit will perform a 30-second booting sequence before starting to operate.

During the booting sequence, the integrated control LED (2 in illustration below) will light GREEN for 5 seconds, and then will turn RED. During this RED light phase, the unit is checking and resetting the motorized damper position. Once the motorized damper position completely set, the RED light turns off and the booting sequence is done.

**NOTE:** No command will be taken until the unit is fully booted.

All units are equipped with an integrated control, located on the upper left side of the unit.

Use the push button (1) to control the unit.

The LED (2) will then show on which mode the unit is in.

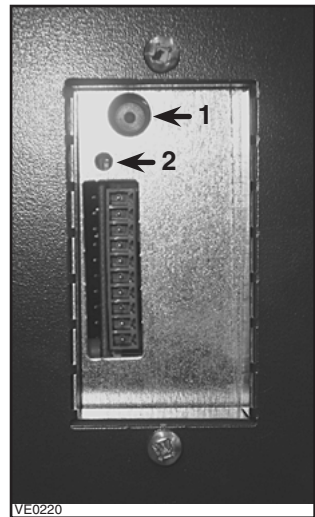

Refer to table below to see how to operate the unit using its integrated control.

PRESS ON PUSH BUTTON	LED COLOR	RESULTS
ONCE	AMBER	UNIT IS ON LOW SPEED
TWICE	GREEN	UNIT IS ON HIGH SPEED
THREE TIMES	NO LIGHT	UNIT IS OFF

If a problem occurs during the unit operation, its integrated control LED (2) will blink. The color of the blinking light depends on the type of error detected. Refer to Section 4 Troubleshooting on last page for further details.

**NOTE: WHEN USING MAIN CONTROL, THE INTEGRATED CONTROL MUST BE TURNED OFF.**

## 2. CONTROLS (CONT'D)

### 2.2 OPTIONAL MAIN CONTROL VT4W

For more convenience, this unit can also be controlled using the optional main wall control VT4W. Only one VT4W can be connected to the unit.

NOTES: 1. The integrated control must be turned OFF to use the optional main control VT4W.

2. If an optional auxiliary control is used, if activated, this auxiliary control will override the VT4W control operation.

When power is applied for the first time or after a power failure, this control is in OFF mode. Activate the push button; the light indicator will show clearly in which operating mode the unit is.

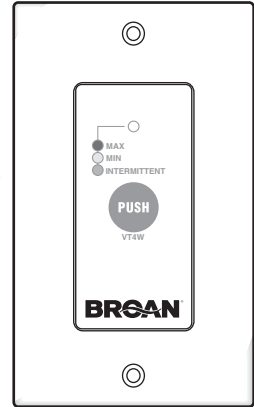

VC0070

LIGHT INDICATOR COLOR	MODE	SUGGESTED USE
GREEN	INTERMITTENT	Select this mode when you are away from the house for a few days. Also, when you deem the inside air is too dry in heating season, or too humid during cooling season. In this mode, the unit is OFF for 40 minutes per hour and ventilates at minimum speed the remaining 20 minutes of the hour.
YELLOW	MIN	Minimum ventilation speed for normal daily operation.
RED	MAX	Maximum ventilation speed for excess pollutants and humidity (parties, odors, smoke, etc.)
NO LIGHT	OFF	Turn off the unit before performing maintenance.

## 2. CONTROLS (CONT'D)

### 2.3 OPTIONAL AUXILIARY CONTROL

Contrary to the optional main control, up to 5 optional auxiliary controls can be connected to the same ventilation unit.

#### 2.3.1 20-MINUTE LIGHTED PUSH BUTTON

Press once on its center (**A**) to activate the push button. The ventilation unit will exchange air with the outside on high speed for a 20-minute period, and the indicator (**B**) will light up. To stop activation before the end of the 20-minute cycle, press one more time. The unit will get back to its previous setting.

NOTE: Control appearance may vary.

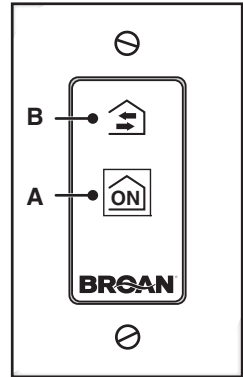

VC0084

#### 2.3.2 60-MINUTE CRANK TIMER

This control makes the unit operate at high speed for periods varying from 10 to 60 minutes.

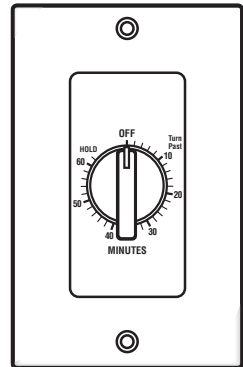

VC0017

#### 2.3.3 DEHUMIDISTAT

Adjust knob to the desired maximum indoor humidity level.

**CAUTION**

**Do not select a humidity level below 30%. This could lead to excessive dryness in the air causing discomfort for the occupants.**

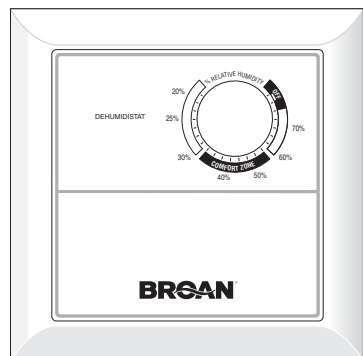

VC0140

### 3. MAINTENANCE

#### **⚠ WARNING**

**Risk of electric shock. Before performing any maintenance, always turn off and disconnect the unit from its power source. Sharp edges may be present. When cleaning the unit, it is recommended to wear safety glasses and gloves.**

Refer to illustration at right to identify the inner parts of your unit.

1. Heat or energy recovery core
2. Core filters

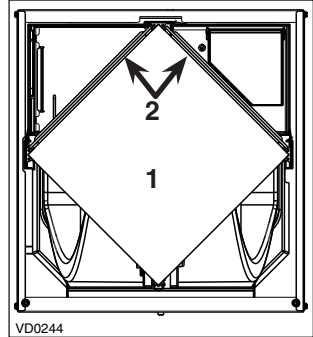

#### 3.1 QUARTERLY MAINTENANCE

- 1 Turn the unit OFF and unplug it.

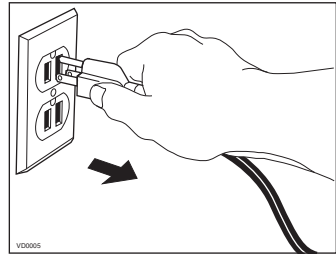

- 2 Remove the unit door by following these steps:
  - A. Remove both door lower machine screws no. 8-32 x 1" (1) and set aside.
  - B. Open (2) and lift out the door (3).

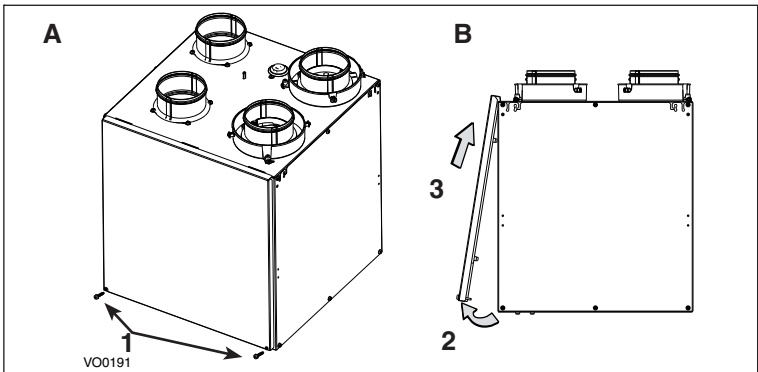

### 3. MAINTENANCE (CONT'D)

#### 3.1 QUARTERLY MAINTENANCE (CONT'D)

- ③ Slide out both filters (1) and recovery core (2) from the unit.
- ④ Clean the inside walls of the unit with a clean damp cloth, then wipe with a clean dry one.
- ⑤ Remove dust on filters and on core using a vacuum cleaner and a soft brush attachment.
- ⑥ Wash both core filters under lukewarm water with mild soap. Rinse thoroughly and let dry completely before reinstalling on the core.

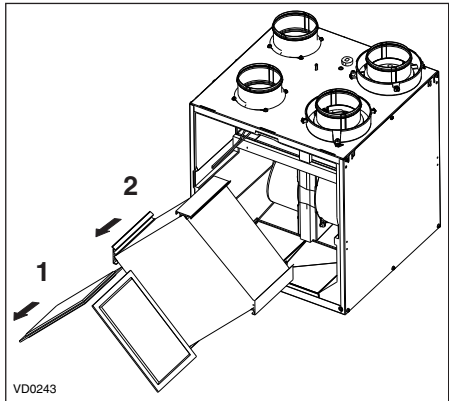

#### CAUTION

**Follow the instructions on the core label to reinstall it correctly.**

- ⑦ Slide the core and the cleaned filters into the unit.
- ⑧ Reinstall the door. Secure it with both mechanical screws no. 8-32 x 1" previously removed and plug the unit.

NOTE: The unit will return to its previous setting after a 30-second delay for boot sequence.



### 3. MAINTENANCE (CONT'D)

---

#### 3.2 ANNUAL MAINTENANCE

Do the same operations as the Quarterly Maintenance (Section 3.1), and clean the recovery core as follows (refer to the core label):

**HRV units:** Soak the heat recovery core in a mixture of lukewarm water and mild soap. Rinse thoroughly. Shake the core to remove excess water and let it dry.

**ERV units:** Remove the dust on the core using a vacuum cleaner and a soft brush attachment.

**All units:** After reinstalling the core, core filters and the unit door, then clean the exterior hoods.

### 4. TROUBLESHOOTING

---

#### **WARNING**

**Shock hazard. Never open the electronic box. No user-serviceable parts inside. There is a fuse on the electronic board. Never attempt to replace it. Refer servicing to qualified service personnel.**

**If the unit does not work properly, reset the unit by unplugging it for one minute and then replug it. If it is still not working properly, refer to table on next page.**

## 4. TROUBLESHOOTING (CONT'D)

	PROBLEMS	YOU SHOULD TRY THIS
1	Unit does not work.	<ul style="list-style-type: none"> <li>• See if the unit is plugged in.</li> <li>• See if the unit is receiving power from the house circuit breaker or fuse.</li> </ul>
2	Condensation on windows (air too humid).	<ul style="list-style-type: none"> <li>• See Controls section on pages 4 to 6.</li> <li>• Leave curtains half-open to allow air circulation.</li> <li>• Store all firewood in a closed room with a dehumidifier or in a well ventilated room, or store the wood outside.</li> <li>• Do not adjust the thermostat of your heating system below 64°F (18°C).</li> </ul>
3	Inside air too dry (on cold season).	<ul style="list-style-type: none"> <li>• See Controls section on pages 4 to 6.</li> <li>• Temporarily use a humidifier.</li> </ul>
4	Air too cold at the air supply grille (on cold season).	<ul style="list-style-type: none"> <li>• Check if the exterior hoods are not blocked, specifically the exhaust air to outside one.</li> <li>• See Controls section on pages 4 to 6.</li> <li>• Install a duct heater.</li> </ul>
5	The LED of the integrated control is blinking GREEN.	<ul style="list-style-type: none"> <li>• There is a problem with the thermistor. <b>The unit is still working</b>, but will defrost frequently. Contact your installer.</li> </ul>
6	The LED of the integrated control is blinking AMBER.	<ul style="list-style-type: none"> <li>• There is a problem with the motorized damper. <b>The unit is OFF</b>. For a 2½-hour period, the unit will try to reset the damper at every 30 minutes. After 2½ hours, if the problem is not solved, the unit stops trying to reset damper.</li> <li>• Contact your installer.</li> </ul>
7	The integrated defrost control push-button does not work.	<ul style="list-style-type: none"> <li>• The 30-second boot sequence is not completed, see step 2.1 Integrated Control on page 4.</li> </ul>

If the problem is still not solved, call your installer or the nearest approved Service Center. Also, you can reach our Customer Service Department or Technical Support listed below:

### Broan-NuTone LLC

- Customer Service Department  
Telephone: 1-800-558-1711  
Fax: 1-800-356-5862

- Technical Support  
Telephone: 1-800-637-1453  
Fax: 1-262-673-8709