

Braeburn®

FLOW-THROUGH BYPASS HUMIDIFIER 17 GPD / 24V

220600 220650

INSTALLER: PLEASE LEAVE INSTALLATION INSTRUCTIONS WITH HOME OWNER

PRECAUTION: The installer should be an experienced service technician. Disconnect electrical power before beginning installation. Do not install where temperatures fall below 32 degrees F or where plenum temperatures exceed 200 degrees F. When wiring into a multi-speed blower circuit see wiring diagrams.

INSTALLATION: The humidifier may be mounted with the 6" outlet to the right or left by inverting the cabinet and reversing the positions of the distributor trough and drain pan. The humidifier may be mounted on the warm or return air plenum with equal efficiency. See Typical Installations.

ADDITIONAL MATERIALS THAT MAY BE NECESSARY:

1. 1/4" diameter plastic supply tubing or 1/4" copper supply tubing for hot water applications
2. 6" diameter galvanized by-pass pipe
3. Electrical wire and wire nuts
4. Current sensing relay (Braeburn Model 229050 suggested)
5. #8 self piercing sheet metal screws

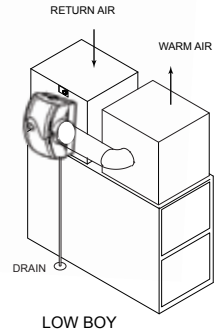
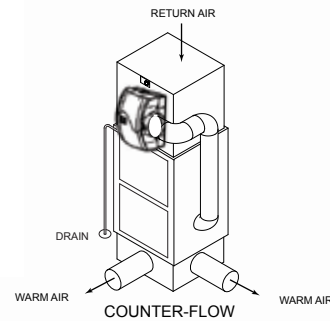
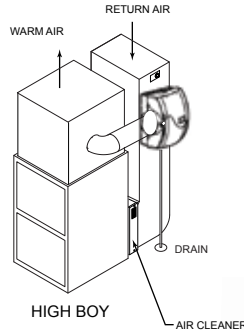

FOR INSTALLATION ON A VERTICAL PLENUM SURFACE OF ANY FORCED AIR FURNACE

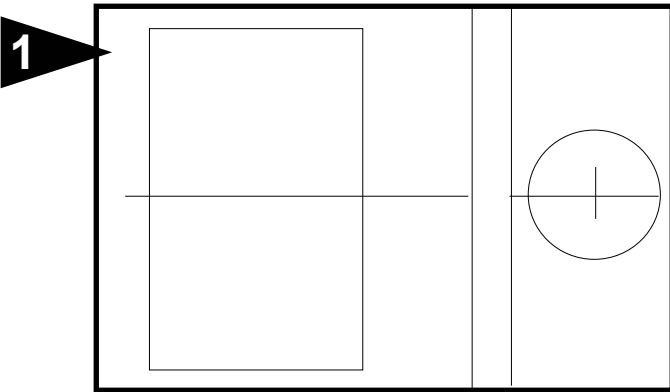

1 Select location on vertical surface of warm or return air plenum for mounting humidifier. Tape mounting template in place making sure the template is level. Do not install humidifier or 6" bypass pipe where the blanked off ends of a cooling coil will restrict air flow to the humidifier. Extend horizontal centerline from template to the adjacent plenum. Scribe 6" circle 10" to 15" from side of humidifier, on cabinet centerline, using connecting collar as guide.

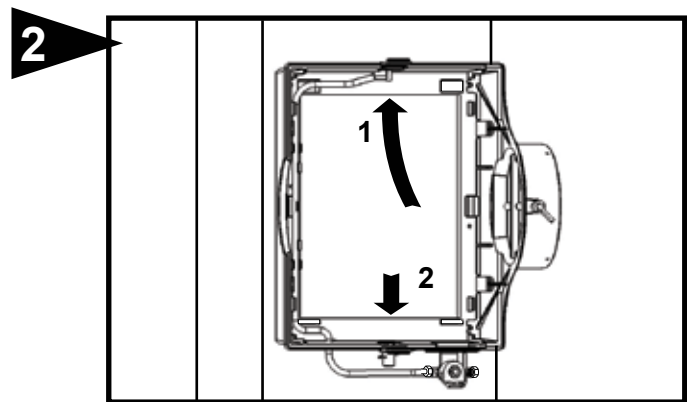

2 Cut out center section of template and 6" hole. Humidifier is self retaining. Slide top side in first, then slide chassis down. Level chassis and install center screws. If by-pass pipe installs to opposite side of chassis, bend clip on chassis, remove side discharge, and reinstall discharge to opposite side of chassis. Install remaining four corner screws.

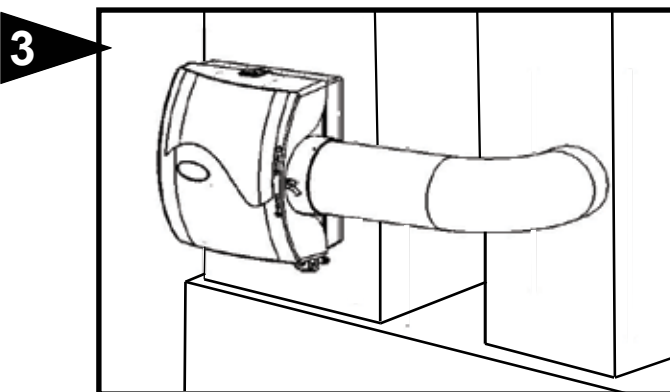

3 Connect by-pass pipe to collar and humidifier cabinet. Using holes at top and bottom of side panel discharge, pierce 2 self tapping screws through by-pass pipe.

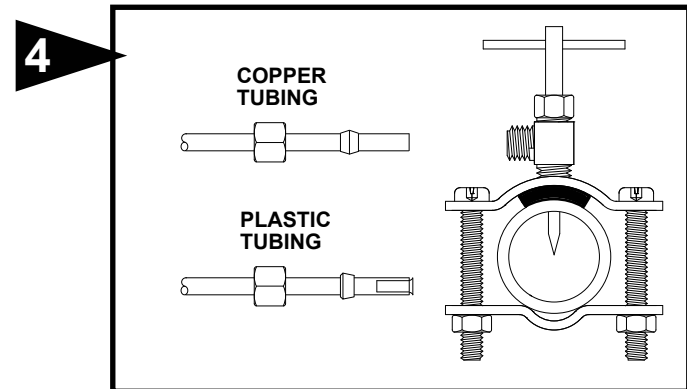

4 Mount the self tapping saddle valve on either a cold or a hot water pipe. A side or top mount is best to avoid clogging from pipe sediment. Connect 1/4" O.D. tubing to the saddle valve. Copper tubing requires a brass compression nut and brass sleeve. Plastic tubing requires a brass insert inside the tubing and a plastic sleeve on the outside with a brass compression nut.

NOTE: DO NOT USE PLASTIC TUBING ON HOT WATER OR IN CONTACT WITH ANY HOT PLENUM SURFACE OR DUCT. INSTALLATION OF THIS SADDLE VALVE MUST MEET OR EXCEED LOCAL CODES AND ORDINANCES.

SADDLE VALVE INSTALLATION INSTRUCTIONS

Copper Pipe

1. Retract piercing pin into valve body by turning handle counterclockwise.
2. Screw valve body into upper bracket and tighten.
3. Place rubber gasket over piercing pin.
4. Assemble saddle valve over copper pipe using enclosed screws, nuts and lower bracket.
5. Tighten screws evenly and firmly. Brackets should be parallel.
6. Complete compression connection to saddle valve outlet.
7. Turn handle clockwise to pierce tubing and close saddle valve.
8. Turn handle counterclockwise to open saddle valve. Leave open for several seconds to flush dirt from pipe and tubing.

Steel, Brass or Hard Plastic Pipe

1. Shut off water supply and drain the water from the supply pipe.
2. Turn handle clockwise to expose piercing pin and close saddle valve.
3. Place rubber gasket over piercing pin.
4. Drill 1/8" hole in pipe using a hand crank drill to reduce shock hazard.
5. Assemble saddle valve over steel, brass or hard plastic pipe using enclosed screws, nuts and lower bracket.
6. Tighten screws evenly and firmly. Brackets should be parallel.
7. Complete compression connection to saddle valve outlet.
8. Turn handle counterclockwise to open saddle valve. Leave open for several seconds to flush dirt from pipe and tubing.

Threaded Pipe Fittings

1. Turn handle clockwise to expose piercing pin and close saddle valve.
2. Seal valve body threads using pipe tape or sealant.
3. Install valve into 1/8" NPT fitting.
4. Complete compression connection to saddle valve outlet.
5. Turn handle counterclockwise to open saddle valve. Leave open for several seconds to flush dirt from pipe and tubing.

5

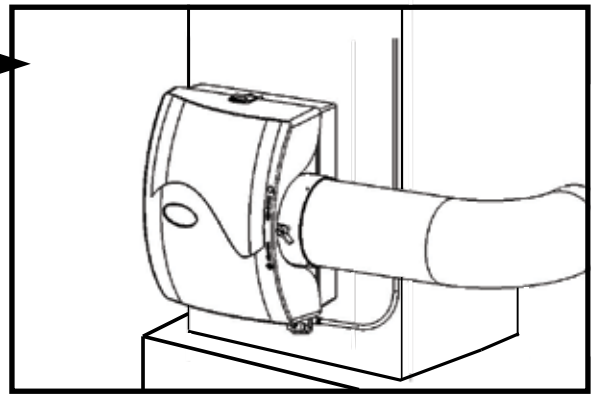

Connect 1/4" water supply tube to brass filter at inlet of solenoid. DO NOT USE PLASTIC TUBING IN CONTACT WITH ANY HOT PLENUM SURFACE OR DUCT. IF USING PLASTIC TUBING, USE INSERT FOR PLASTIC TUBING AND PLASTIC COMPRESSION SLEEVE (INCLUDED WITH SADDLE VALVE KIT).

6 THE BRAEBURN® 220600 INCLUDES MANUAL HUMIDISTAT (MODEL 229100) THE BRAEBURN® 220650 INCLUDES DIGITAL HUMIDISTAT (MODEL 229150)

HUMIDISTAT WIRING

PLEASE SEE COMPLETE SET OF INSTRUCTIONS SUPPLIED WITH HUMIDISTAT

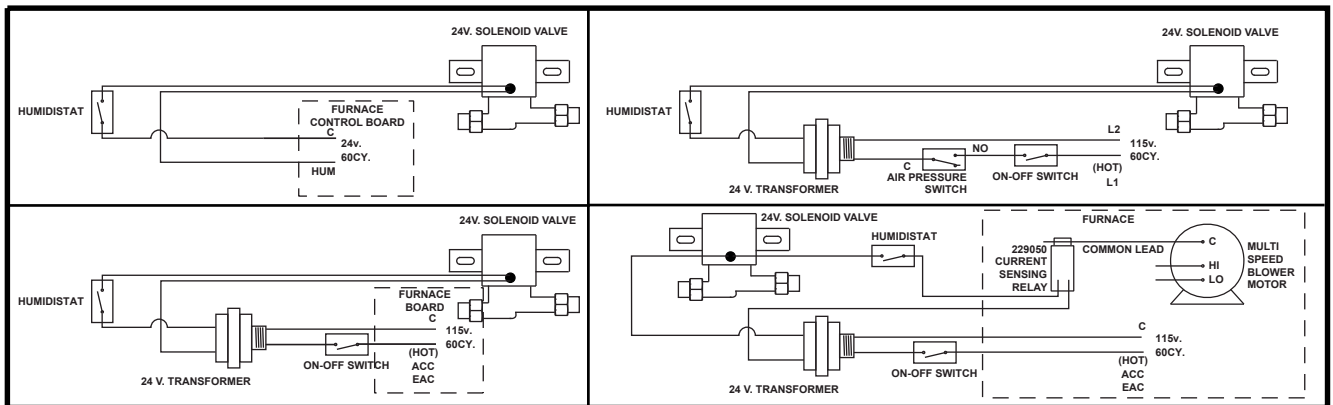

PRECAUTIONS

The installer should be a qualified Technician. Disconnect electrical power before beginning installation. Install the humidistat on the return duct using the foam gasket. Conduct a thorough checkout before leaving the installation.

PARTS LIST FOR HUMIDIFIER

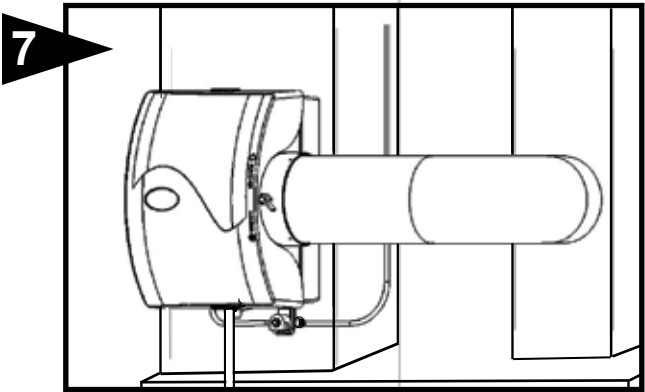
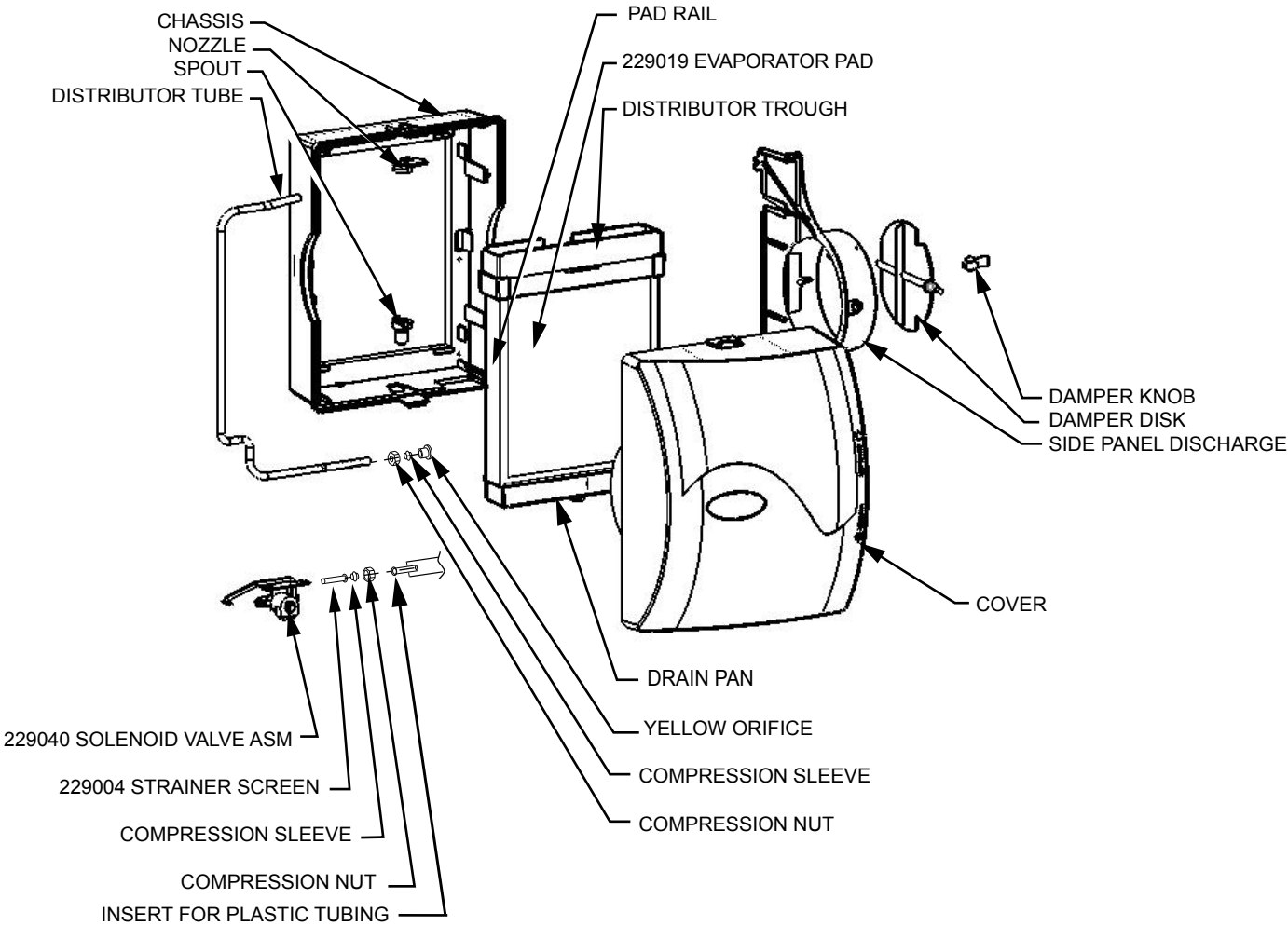

8 Turn damper knob to winter (open) position. Turn on water supply and check operation of humidifier. Set humidistat to a demand setting. With the furnace off, the solenoid valve should be closed. Start the furnace. The solenoid valve should open when the blower or burner circuit is energized. Check flow of water through distributor trough and evaporator pad. The standard (yellow) orifice will supply approximately 3.5 GPH of water at a line water pressure of 60 psi. Leave humidistat set at the recommended setting.

7 Connect drain hose to 1/2" spout on humidifier cabinet using hose clamp. Run 1/2" hose to suitable drain such as floor drain, sewer or laundry sink. Be sure hose has continuous slope and is not kinked at any point.

CARE AND MAINTENANCE

Your humidifier is engineered to give helpful and trouble-free humidification. For maximum efficiency the following cleaning procedures should be carried out at the end of each heating season:

1. Turn off water supply and electrical power to humidifier.
2. Remove cover, distributor trough, evaporator pad and drain pan. Clean excessive mineral deposits from the distributor trough, drain pan, pad rails, and humidifier cabinet. A solution of 1/2 vinegar & 1/2 water will help loosen mineral deposits.
3. If the evaporator pad has excessive mineral deposits, replace with a new evaporator pad (Model 229019). Install trough and drain pan. Replace cover.
4. In heavy mineral areas or if the solenoid valve fails to function disconnect the 1/4" water supply line from the solenoid valve. Carefully pull the strainer screen (Model 229004) from the valve body. Clean the mineral deposits from all parts. If the orifice is clogged, it may be opened by inserting a small pin. Reinsert the filter into the orifice fitting and screw the brass strainer body into the solenoid valve.
5. Reconnect the 1/4" water line to the solenoid valve if necessary. Turn on the water supply and check all points for leakage. The operation of the unit may be checked by starting the furnace. The humidifier operates only when the furnace blower is running or the burner circuit is energized. The humidifier is now ready for operation.
6. During the summer, turn off water supply and electrical power to humidifier. Set air damper to summer position.

AT OUTSIDE TEMPERATURE		RECOMMENDED SETTING
40°F	4°C	45%
30°F	-1°C	40%
20°F	-7°C	35%
10°F	-12°C	30%
0°F	-18°C	25%
-10°F	-23°C	20%
-20°F	-29°C	15%

HOW THE HUMIDIFIER WORKS

The operating principle of the humidifier is based on an efficient and economical means of evaporating water to the air. The humidifier uses only 2.5 watts of electrical power during operation, less than most household light bulbs. The heat necessary for evaporating water is produced by the furnace.

The water supply to the humidifier is controlled by the electric solenoid valve. The humidistat connected in series with the solenoid provides low voltage control of the humidifier. The humidistat is designed for wall mounting in the living area or surface mounting on the return air duct.

ELECTRICAL RATING: 24 VAC / 60 Hz.

DO NOT SET RELATIVE HUMIDITY TOO HIGH DURING COLD WEATHER. EXCESSIVE HUMIDITY MAY CAUSE CONDENSATION ON WINDOWS OR IN WALLS. REFER TO RECOMMENDED SETTINGS AS DESCRIBED IN THE HUMIDISTAT OWNERS MANUAL.

Water flows through a strainer, is metered through an orifice to provide the proper amount of water, and is supplied to the evaporator pad by the distributor trough. Approximately 200 CFM of air is by-passed from the warm air plenum through the humidifier and returned to the cold air plenum. Moisture is evaporated to the air passing through the evaporator pad.

Minerals are not blown into the air stream as occurs in atomizing humidifiers; they are left on the evaporator pad where a high percentage is carried off with the waste water.

When the humidifier is installed and operating, no adjustments are necessary other than setting the control knob on the humidistat to the desired level of humidification. When in operation, leave knob on the humidifier in "WINTER" position.

To turn the humidifier off, close water supply valve, switch electrical power off and turn humidistat off. If furnace is used for summer cooling or ventilating set air damper to "SUMMER".

LIMITED WARRANTY

Braeburn Systems LLC warrants each new Braeburn humidifier against any defects that are due to faulty material or workmanship for a period of five years after the original date of purchase by a professional service technician. This warranty and our liability does not include damage to merchandise or the humidifier resulting from accident, alteration, neglect, misuse, improper installation or any other failure to follow Braeburn installation and operating instructions.

Braeburn Systems LLC agrees to repair or replace at its option any Braeburn humidifier under warranty provided it is returned postage prepaid to our warranty facility in a padded carton within the warranty period, with proof of the original date of purchase and a brief description of the malfunction. This limited warranty does not include the cost of removal or re-installation.

This warranty gives you specific legal rights and you may also have other rights that vary from state to state or province to province. Answers to any questions regarding our limited warranty may be obtained by writing our corporate offices.

WARRANTY FACILITY: Braeburn Systems LLC
Attn: Warranty Department
2215 Cornell Avenue
Montgomery, IL 60538



Braeburn

Braeburn Systems LLC
2215 Cornell Avenue • Montgomery, IL 60538
Technical Assistance: www.braeburnonline.com
Call us toll-free: 866-268-5599 (U.S.)
630-844-1968 (Outside the U.S.)