

Braeburn[®]

Premier 3-Zone Controller
model 140303

Installer Guide



CONTENTS

1 Specifications

2 Suitable Mounting Locations

3 Wiring Diagrams

4 Configuration

5 System Checkout

6 Operation



Warning

- Read all of the instructions before proceeding.
- Always turn off power to the heating/air conditioning system prior to installing or adjusting the Premier 3-Zone Controller. Wire the entire panel before applying transformer power.
- This controller should only be installed and configured as described in this manual. Any other use is not recommended and will void the warranty.

1 Specifications

- Storage temperature: -40°–150° F (-40°–65° C)
- Operating temperature: -20°–125° F (-30°–50° C)
- Operating humidity: 5–95% RH
- Voltage: 24 VAC, 60Hz
- Max. damper power: 35 VA @ 24 VAC
- Dimensions: See Figure 1

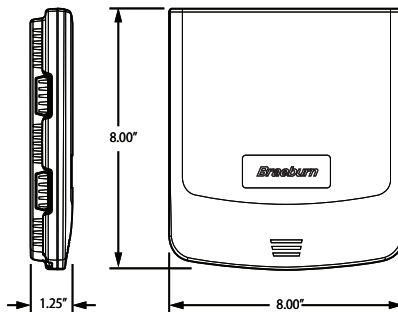

Figure 1

2 Suitable Mounting Locations

Mount the Premier 3-Zone Controller panel near the HVAC equipment (see Figure 2). The panel can be mounted in any orientation on a wall, stud, roof truss, or the return-air plenum. For appearance, mount the panel level.

Remove the panel cover and use the base as a template to drill mounting holes 6.5" apart (see Figure 3). Attach the panel with appropriate screws (not included). Use mounting anchors as needed for drywall or plaster installations.

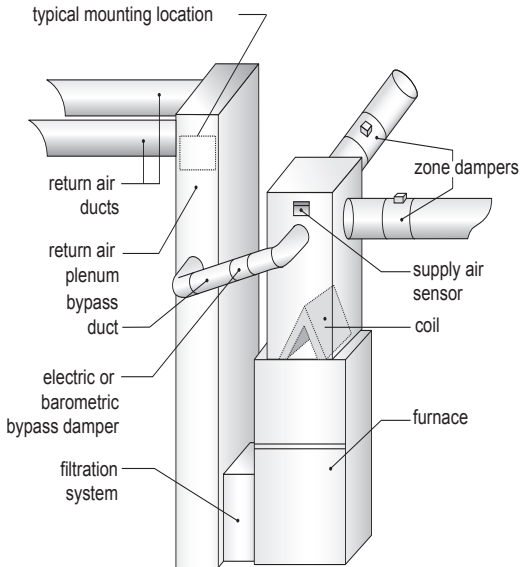

Figure 2

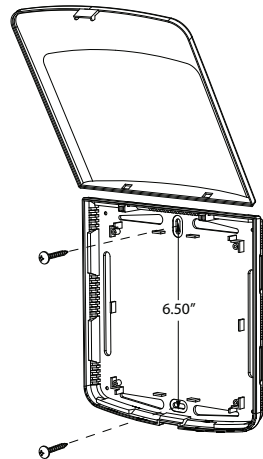

Figure 3

3 Wiring the Panel



Always turn off power to the heating/air conditioning system prior to installing or adjusting the Premier 3-Zone Controller. Wire the entire panel before applying transformer power.

Use the following general wiring instructions for all systems. Specific wiring will vary depending on the equipment and type of system (conventional or heat pump).

3.1 Damper Wiring

Install the system dampers using the instructions provided by the manufacturer.

Connect the dampers to the zone panel as shown for either a 2-wire or 3-wire damper.

The sum of all dampers powered by the zone panel should not exceed 35 VA at 24 VAC. Use a slave relay if additional damper power is required.

Max. damper VA per panel	35 VA @ 24 VAC
--------------------------	----------------

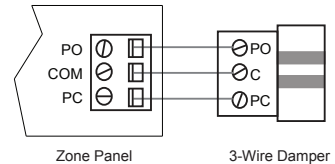
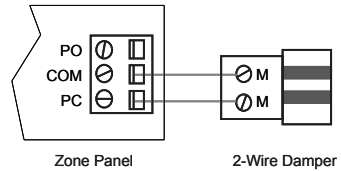

3.2 Thermostat Wiring

Install the system thermostats using the instructions provided by the manufacturer.

Connect the thermostats to the zone panel as shown.

Notes:

- Wiring to the C terminal is required only for thermostat power.
- E terminal at thermostat 1 controls emergency heat. See E-Heat Switch Installation Sheet 1192EHS for wiring details.

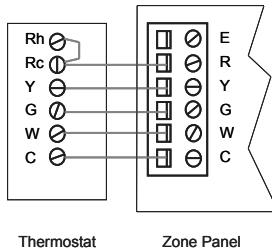

3.3 Supply Air Sensor Wiring

Install the supply air sensor in the supply air plenum at least 2-3 feet after the heat exchanger and coil. Make sure there are no zone dampers before the supply air sensor.

Connect the supply air sensor to the zone panel as shown.

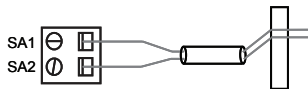

3.4 Transformer Wiring

Install the transformer using the instructions provided by the manufacturer. Size the transformer to the damper requirements. The zone panel has a built-in, self-resetting fuse. The maximum damper power per panel is 35 VA at 24 VAC.

Connect the transformer to the zone panel as shown.

Note: *Additional dampers or dampers with a higher current draw will require the use of a separate slave relay.*

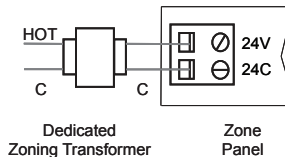

3.5 Conventional System Wiring

Note: For a heat pump system, see Section 3.6.

Connect a conventional heating system to the zone panel as shown.

For a single stage heating and cooling system, the 2nd stage connections are not used.

For a system using a dual transformer, open jumper J1 (see Configuration section, Figure 4). Make sure the the neutrals (common) are connected.

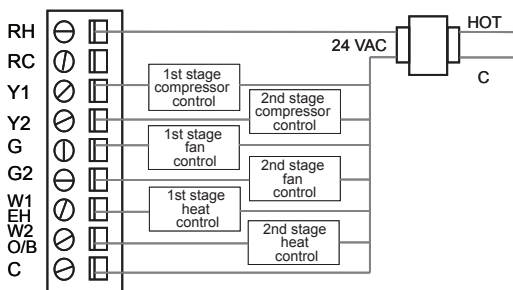

3.6 Heat Pump System Wiring

Connect a single or multi-stage heat pump system to the zone panel as shown.

A conventional thermostat may be used with a heat pump system, however, emergency heat will be controlled by the panel emergency heat switch or the optional remote emergency heat switch.

For a single-stage system, the auxiliary heat control is not used. For a multi-stage system, the compressor controls are not used.

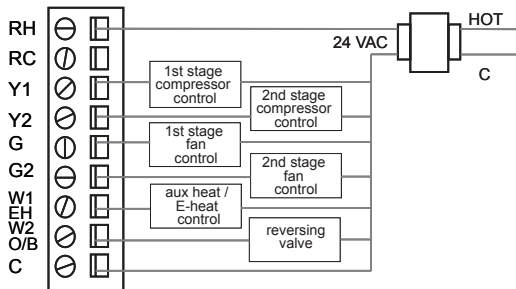

- Use DIP switch 1 to select between conventional and heat pump system.
- Use DIP switch 3 for heat pump reversing valve control. Setting 0 means that the O/B terminal is active in a cooling call. Setting B means that the O/B terminal is active in a heating call.

4 Configuration

Use the following instructions to configure the Premier 3-Zone Controller.

1. Open J1 jumper for dual transformer installations.
2. Open J2 short cycle protection jumper for system test.

Note: Replace J2 when system testing is completed or leave J2 open if compressor has built in short cycle protection.

3. Press ▲ and then press ▲ to raise or ▼ to lower the Hi Temp cutout.
4. Press ▼ and then press ▲ to raise or ▼ to lower to Low Temp cutout.

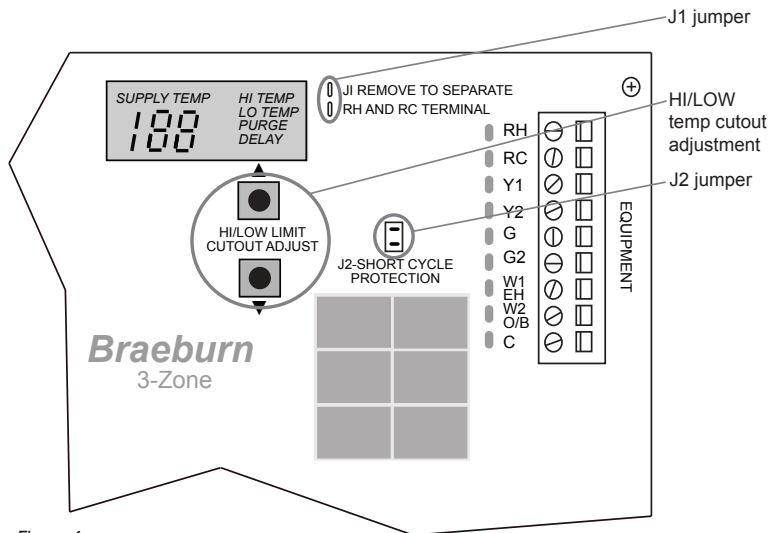
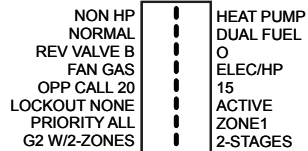

Figure 4

5. Set the DIP switches to meet system requirements.



	Switch Label	Function
1	Non-HP / Heat Pump	Conventional or heat pump control of W/Y
2	Normal / Dual Fuel	HP 1st stage lockout on 2nd stage call
3	Rev Valve B/O	O/B terminal active in heating (B position) or cooling (O position)
4	Fan Gas / Elec & HP	Fan controlled by HVAC system or panel
5	Opp Call 20 / 15	Opposite call answer time in minutes
6	Lockout None / Active	2nd stage lockout without 2 zones calling
7	Priority All / Zone 1	Changeover priority zone 1 or first call
8	G2 W/2-Zones / 2 Stages	2nd stage fan activation requires 2 zones or 2 stages

5 System Checkout

After the wiring and configuration is complete, use the following checklist to verify the panel operation is correct.

- [] Make sure the Emergency Heat Switch is in the Off (right) position.
- [] Open jumper J2 by moving cap from both pins to only one pin.
- [] Use table and diagram in section 4 of this installer guide or inside the zone panel cover to verify DIP switches are set properly.
- [] Make sure the supply temp sensor is wired to terminals SA1 and SA2. The zone dampers will not close if the supply sensor is missing.
- [] Make sure no zones are calling by turning off all thermostats.
- [] Apply 24 VAC power to the panel.

- [] Verify green power LED near 24 VAC terminals is lit.
- [] Verify green heartbeat LED in middle of panel is pulsing.
- [] Verify all 3 zone LEDs near damper terminals are green.
- [] Verify supply temp display shows current plenum temperature.
- [] Switch zone 1 thermostat to heat mode, and call for heat in zone 1 by raising set temperature above room temperature.
- [] Verify zone 1 damper LED stays green (open) and zone 2 and 3 damper LEDs change to red (closed).
- [] Verify heating system is operating, air is moving out zone 1 vents, and zone 2 and 3 vents have minimal airflow.
- [] Verify supply temp display on zone panel shows a heat change in supply air.
- [] Switch zone 2 thermostat to heat mode, and call for heat in zone 2 by raising set temperature above room temperature.
- [] Verify zone 1 damper LED stays green (open) and zone 2 damper LED changes to green (open).
- [] Verify heating system is operating and air is moving out into zone 1 and zone 2.
- [] If installed, switch zone 3 thermostat to heat mode, and call for heat in zone 3 by raising set temperature above room temperature. Verify air is now flowing to zone 3.
- [] If installed, verify emergency heat remote and panel switch. Return E-Heat switches to normal position when test is complete.
- [] Return zone 1 thermostat to the off position. Verify zone 1 damper LED turns red and zone 2 and 3 damper LEDs stay green.
- [] Verify heating system is operating, air is moving out zone 2 and 3 vents, and zone 1 vents have minimal airflow.
- [] Return zone 2 and 3 thermostats to the off position. Verify system fan shuts off at the end of 90-second purge cycle.
- [] Verify all zone LEDs near damper terminals are green.
- [] If the outside temperature is acceptable, repeat the above steps in cooling mode. Cooling will not work if E-Heat is on.
- [] Restore thermostats and replace J2 jumper if short cycle protection at zone panel is required.

6 Operation

The Premier 3-Zone Panel has LEDs and a built-in display to tell the installer and homeowner the current operating mode of the panel. Refer to Figure 5 and the following descriptions of the panel LEDs for operation information.

LED Display Panel

Supply Temp	Shows the current air supply temp. Use to set Hi/Lo temp limit.
Hi Temp	Press ▲ to display Hi temp cutout setting. Press ▲ to raise or ▼ to lower Hi temp setting.
Lo Temp	Press ▼ to display Lo temp cutout setting. Press ▲ to raise or ▼ to lower Lo temp setting.
Purge	System uses intelligent purge to maximize comfort and energy savings.
Delay	Supply air temperature is outside the Hi/Lo temp cutout. System has turned off the equipment except the fan.

Callout	LED	Description
1	Thermostats	Shows what calls the thermostats are making to the zone panel. Lights when thermostat terminal is active.
2	24V Power	Lights when the panel is receiving power from the zoning transformer.
3	RH and RC	Lights when the HVAC equipment transformer(s) are receiving power. Available only when C equipment terminal is wired.
4	Equipment	Lights when the zone panel is calling to the equipment. Zone panel controls the equipment LEDs in response to thermostat calls and DIP switch settings.
5	Emergency Heat	Lights when emergency heat is active (cooling is disabled).
6	Damper	Lights red when the zone damper is closed, green when the zone damper is open.
7	Heartbeat	Flashes once per second when the panel is normal.

LED display panel

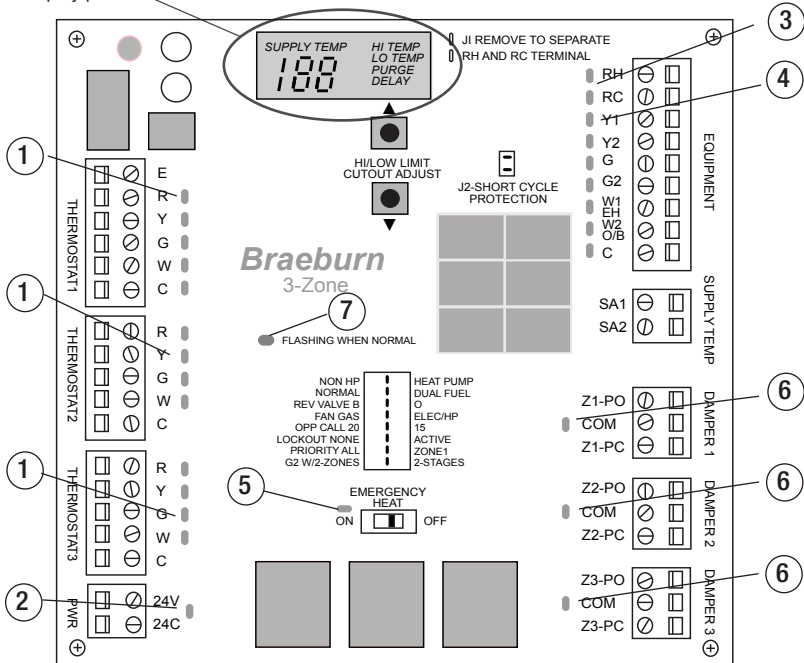

Figure 5

Notes:

- When no zones are calling, the panel will command all dampers to open.
- For maximum energy conservation, a 90 second purge will occur at the end of each call. No calls will be answered until the purge is complete.
- Equipment staging is automatic based on time and plenum temperature.
- Dampers will not close and staging will not occur if the plenum temperature sensor is not connected and functioning properly.
- No cooling calls will be answered if emergency heat is switched on.

Braeburn[®]

Warranty

Braeburn Systems LLC warrants each new Braeburn zone panel against any defects that are due to faulty material or workmanship for a period of five years after the original date of purchase by a professional service technician. This warranty and our liability does not apply to merchandise or the zone panel resulting from accident, alteration, neglect, misuse, improper installation or any other failure to follow Braeburn installation and operating instructions.



Braeburn Systems LLC agrees to repair or replace at its option any Braeburn zone panel under warranty provided it is returned postage prepaid to our warranty facility in a padded carton within the warranty period, with proof of the original date of purchase and a brief description of the malfunction. This limited warranty does not include the cost of removal or re-installation.

This warranty gives you specific legal rights and you may also have other rights that vary from state to state or province to province. Answers to any questions regarding our limited warranty may be obtained by writing our corporate offices.

WARRANTY FACILITY: Braeburn Systems LLC
Attn: Warranty Department
2215 Cornell Avenue
Montgomery, IL 60538

Braeburn[®]

Braeburn Systems LLC
2215 Cornell Avenue • Montgomery, IL 60538
Technical Assistance: www.braeburnonline.com
Call us toll-free: 866.268.5599 (U.S.) or +1.630.844.1968 (Outside the U.S.)

©2008 Braeburn Systems LLC • Patents Pending • All Rights Reserved.
Part. No. 140303-140-001
Made in China.