

# 30" Induction Cooktop with Touch Control

## 300 Series - Black

### NIT3065UC

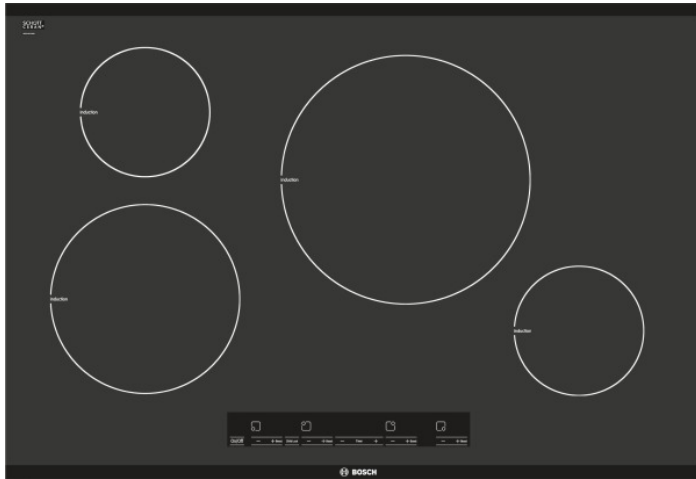

## Features and Benefits

### Key Features

- 11" Heating Element with Powerful 3600W
- Countdown Timer - Built-In Timers for Each Element. Doubles as General-Purpose Kitchen Timer.
- SpeedBoost™ - This Fast-heat Mode Boils Water Twice as Fast as Conventional Electric Cooktops, Saving Time and Energy.

### Performance

- 11" Heating Element with Powerful 3600W
- SpeedBoost™ - This Fast-heat Mode Boils Water Twice as Fast as Conventional Electric Cooktops, Saving Time and Energy.

### Efficiency

- PotSense™ - Automatically Adjusts Cooking Element to the Size of the Pan Bottom

### Convenience

- Countdown Timer - Built-In Timers for Each Element. Doubles as General-Purpose Kitchen Timer.
- Keep Warm Function - Perfect for Melting Chocolate or Butter or Keeping Food Warm
- Overflow Detection - Sounds Alarm and Shuts off Cooktop in Case of an Overflow
- ChildLock - Prevents the Cooktop from Being Accidentally Switched on. Locks Temperature Settings if in Use.
- SafeStart - Ensures that Element is Only Activated, if Suitable Cookware is in Position; no Activation When Other Metal Objects are Placed on Element
- Anti-Overheat System - Shuts off Cooktop, if Surface Temperature Exceeds a Set Value
- 2-Level Heat Indicator - Warns if Cooktop is Warm or Hot

Notes: All height, width and depth dimensions are shown in inches. \*Please refer to installation instructions prior to making cutout. BSH reserves the absolute and unrestricted right to change product materials and specifications, at any time, without notice. Consult the product's installation instructions for final dimensional data and other details. Applicable product warranty can be found in a accompanying product literature or you may contact your account manager for further details.

For more information on our entire line of products, go to [boschappliances.com](http://boschappliances.com) or call 1-800-944-2904.

Copyright ©2014 BSH Home Appliances Corporation. All rights reserved. Bosch is a registered trademark of Robert Bosch GmbH.

Litho Date: 01/2014

# 30" Induction Cooktop with Touch Control

## 300 Series - Black

### NIT3065UC

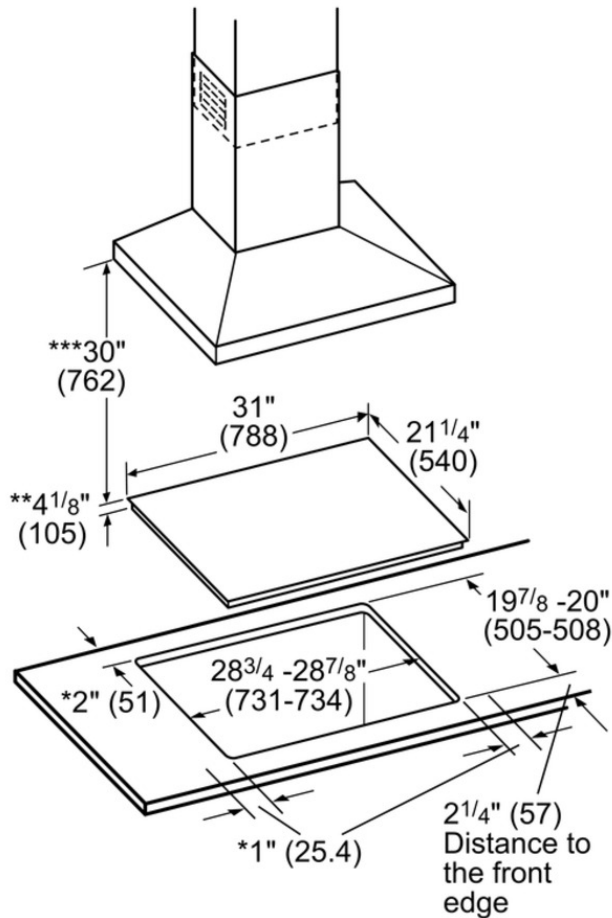

- \* Minimum distance from the cooktop cutout to the wall
- \*\* Installed depth includes 1" (26 mm) air clearance
- \*\*\* Minimum distance between surface of the cooktop and lower edge of the exhaust hood.

Dimensions in inches (mm)

#### Features

Knob Material	
Sealed Burners	No
Burners with booster	All
Type of grate	
Total BTU load	
LP Gas Connection Rating (BTU)	
Power of 1st heating element (kW in boost)	3.3
Dimension of 1st heating element (in)	9"
Power of 2nd heating element (kW in boost)	1.8
Dimension of 2nd heating element (in)	6"
Power of 3rd heating element (kW in boost)	3.6
Dimension of 3rd heating element (in)	11"
Power of 4th heating element (kW in boost)	1.8
Dimension of 4th heating element (in)	6"
Power of 5th heating element (kW in boost)	
Dimension of 5th heating element (in)	
Power of 6th heating element (kW in boost)	
Dimension of 6th heating element (in)	

#### Technical Specification

UPC code	825225876526
Variant color	Black
Energy source	Electric
Gas type	
Alternative gas type	
Watts (W)	7200
Current (A)	40
Volts (V)	208-240
Frequency (Hz)	60
Approval certificates	CSA
Power Cord Length	37"
Plug type	no plug
Required cutout size (HxWxD) (in)	4 1/8" x 28 3/4" x 19 7/8"
Minimum distance from counter front (in)	2 1/4"
Minimum distance from rear wall (in)	2"
Overall appliance dimensions (HxWxD) (in)	1/4"+4 1/8" x 31" x 21 1/4"
Product packaging dimensions (HxWxD) (in)	7 1/16" x 36 5/8" x 26 5/8"
Net weight (lbs)	42
Gross weight (lbs)	49
Total number of cooktop burners	4

Notes: All height, width and depth dimensions are shown in inches. \*Please refer to installation instructions prior to making cutout. BSH reserves the absolute and unrestricted right to change product materials and specifications, at any time, without notice. Consult the product's installation instructions for final dimensional data and other details. Applicable product warranty can be found in a accompanying product literature or you may contact your account manager for further details.

For more information on our entire line of products, go to [boschappliances.com](http://boschappliances.com) or call 1-800-944-2904.  
Copyright ©2014 BSH Home Appliances Corporation. All rights reserved. Bosch is a registered trademark of Robert Bosch GmbH.

Litho Date: 01/2014