

36" Counter Depth Side-by-Side Refrigerator

300 Series - Stainless Steel

B22CS30SNS



Features and Benefits

Key Features

- Counter-Depth
- Dual Evaporator
- Multi-Flow Shower Cooling System™
- Frameless Exterior Ice and Water Dispenser with LED Illumination
- ENERGY STAR® Qualified

Design

- Counter-Depth
- Long Doors
- Hidden Hinges
- Frameless Exterior Ice and Water Dispenser with LED Illumination

Performance

- Dual Evaporator
- AntiBacteria Wall Lining
- Spill-proof Glass Shelves
- Humidity Controlled Crispers
- SuperCool™
- SuperFreeze™

Efficiency

- ENERGY STAR® Qualified

Convenience

- Full Extension Drawers
- Dispenser Control Lock
- Door Open Alarm

Capacity

- Hide-away Water Filter



Notes: All height, width and depth dimensions are shown in inches. *Please refer to installation instructions prior to making cutout. BSH reserves the absolute and unrestricted right to change product materials and specifications, at any time, without notice. Consult the product's installation instructions for final dimensional data and other details. Applicable product warranty can be found in a accompanying product literature or you may contact your account manager for further details.

For more information on our entire line of products, go to boschappliances.com or call 1-800-944-2904.
Copyright ©2014 BSH Home Appliances Corporation. All rights reserved. Bosch is a registered trademark of Robert Bosch GmbH.

Litho Date: 01/2014



36" Counter Depth Side-by-Side Refrigerator

300 Series - Stainless Steel

B22CS30SNS

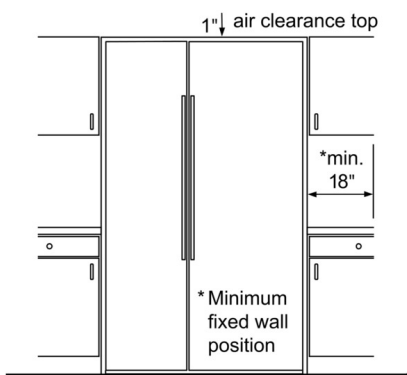
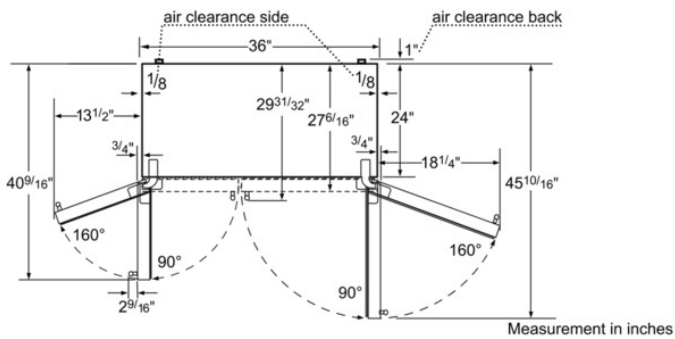
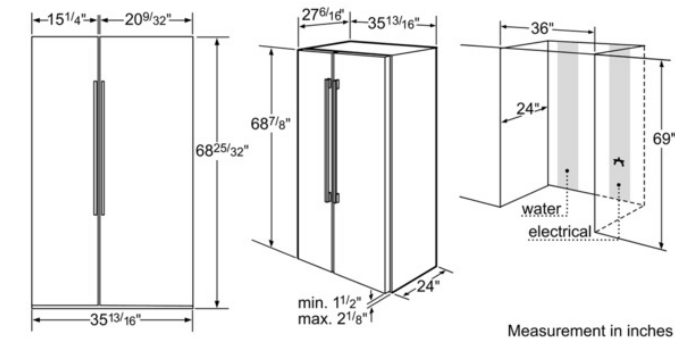

Features

Multi-Flow Air Tower	Yes
SUPERCOOL	Yes
SUPERFREEZE	Yes
Carbon Air Filter	No
Temperature Controlled Drawer	No
Humidity Control Drawer	Yes
Number of Door Bins - Refrigerator	2
Adjustable Door Bins - Refrigerator	No
Tilt-Out Door Bins - Refrigerator	Yes
Gallon Storage Bins	2
Number of Shelves - Refrigerator	4
Door Hinge	left and right
Adjustable Shelves - Refrigerator	3
Number of Shelves - Freezer	2
Reversible Door Hinge	No
Adjustable Shelves - Freezer	Yes

Technical Specification

UPC code	825225868729
Color / Material housing	Chrome Inox-metallic
Colour.Material door	Stainless steel
Panel ready	
Silence level (dBA)	44
Watts (W)	300
Current (A)	10
Volts (V)	115
Frequency (Hz)	60
Total annual energy consumption (kWh)	544.95
Energy Star® qualified	Yes
Approval certificates	UL
Power Cord Length	87"
Required cutout size (HxWxD) (in)	69" x 36" x 24"
Appliance Width (in)	36"
Height (in)	69"
Depth (in)	30"
Capacity in 0.75l (bordeaux bottles)	
Total unit gross capacity (cu. ft.) - AHAM	22
Product packaging dimensions (HxWxD) (in)	72.44 x 38.38 x 32.87
Refrigerator Gross capacity (cu. ft.)	14
Freezer Gross capacity (cu ft)	8
Net weight (lbs)	338
Gross weight (lbs)	354
SKU	B22CS30SNS

Notes: All height, width and depth dimensions are shown in inches. *Please refer to installation instructions prior to making cutout. BSH reserves the absolute and unrestricted right to change product materials and specifications, at any time, without notice. Consult the product's installation instructions for final dimensional data and other details. Applicable product warranty can be found in a accompanying product literature or you may contact your account manager for further details.

For more information on our entire line of products, go to boschappliances.com or call 1-800-944-2904.
Copyright ©2014 BSH Home Appliances Corporation. All rights reserved. Bosch is a registered trademark of Robert Bosch GmbH.

Litho Date: 01/2014

