

Lift mechanism set

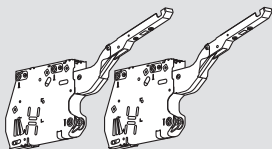

- Lift mechanism (qty 2)
- #7 x 35 mm (1-3/8") wood screw (qty 10)

Power factor	Opening angle	Part no.
43 — 99	107°	20K2300.N5
100 — 174	107°	20K2500.N5
175 — 349	107°	20K2700.N5
350 — 792	100°	20K2900.N5

Cover set

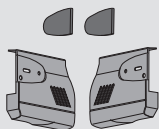

- Right and left cover plate
- Non-handed cover cap (qty 2)

Part no.
Cover set

20K8000.NA

Narrow aluminum hardware set

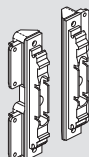

- Arm assembly mounting plate (qty2)
- 669.110 — Aluminum screw for narrow aluminum lever arm mounting plate (qty 8)

Part no.
Narrow aluminum hardware set

20S4200A

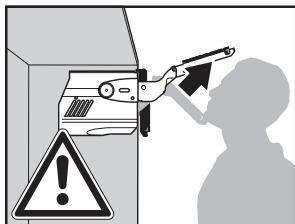

WARNING

Risk of injury from spring-loaded arm

- Do not push arm assembly down or leave in the down position
- Remove mechanism before installing or removing cabinet

1 Locating pin locations and minimum depth

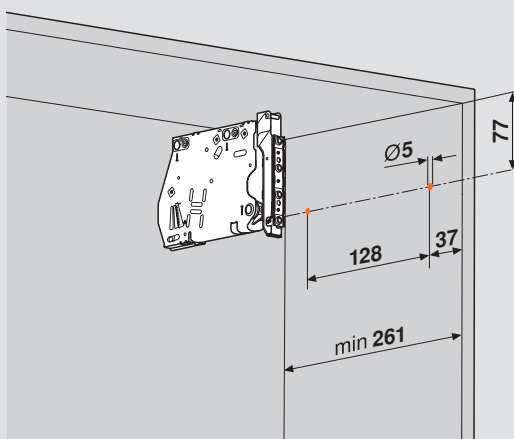

Part no.

Universal individual template is available for pre-boring 5 mm locating pins

65.1051.02

2 Attaching the lift mechanism

Align the lift mechanism in the cabinet using the 5 mm locator pins and attach the mechanism with the three wood screws provided.

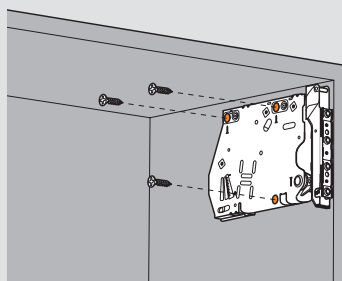
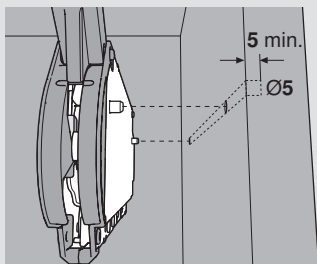

#7 x 35 mm (1-3/8") wood screws (qty 3)

3 Remove transport tab from lift mechanism and raise arms

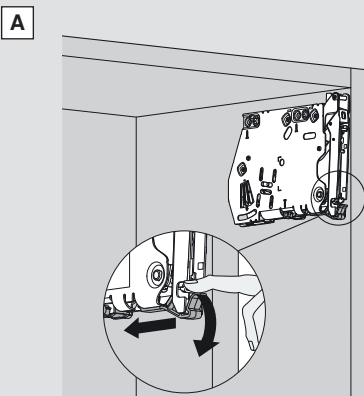

Carefully remove the transport tab.

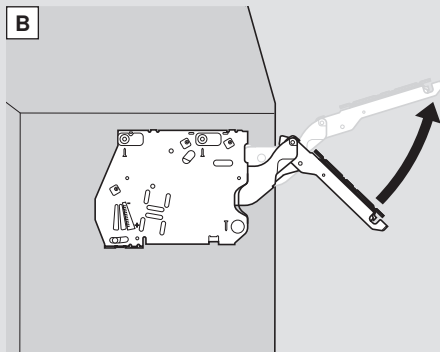

Raise the arm to the upright position.



Risk of injury from spring loaded arm.

NOTE: Do not remove transport tab until just before attaching the door

4a Mounting plate position

Attach the mounting plate to the door.

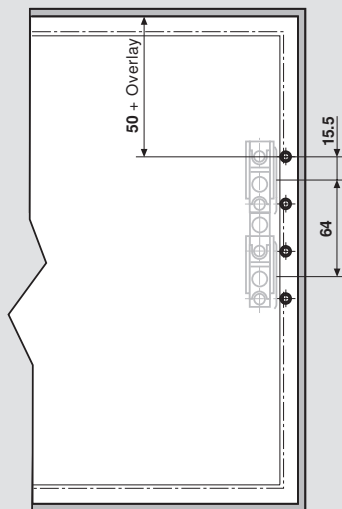

NOTE: All four screws must be installed

4b Planning narrow alum. frames

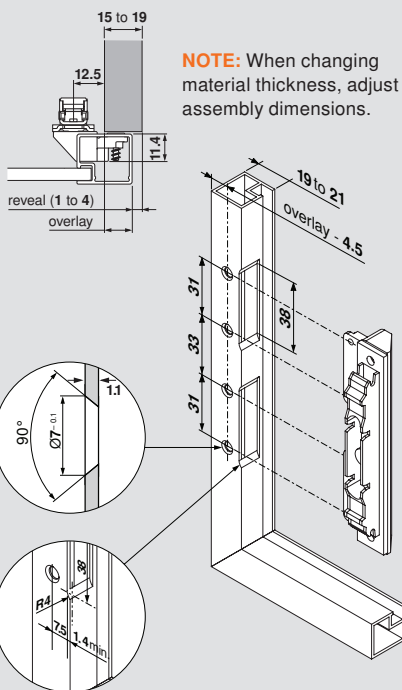

NOTE: When changing material thickness, adjust assembly dimensions.

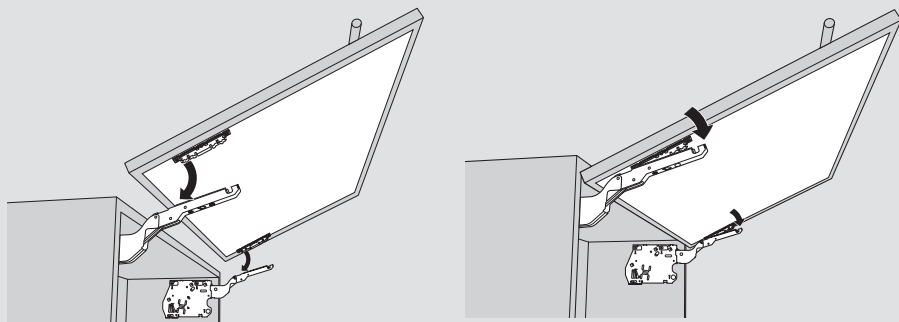
5 Attaching the door

Attach the door using the CLIP mechanism in the mounting plate.

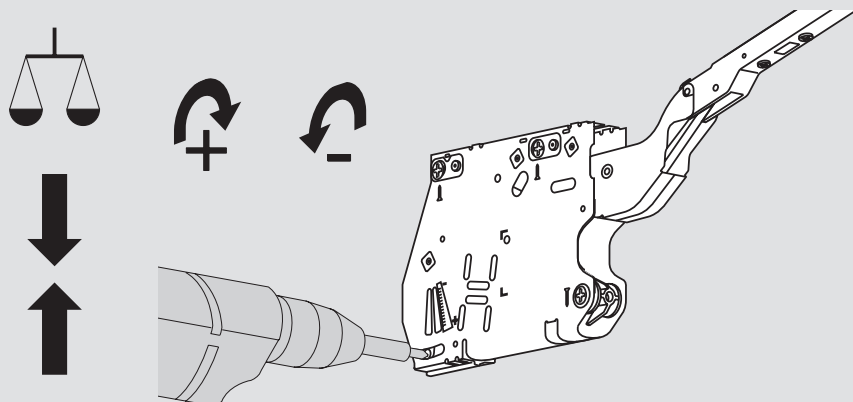
6 Adjust the door tension

Use a screw gun and the supplied #2 x 2 POZI driver bit to adjust the lift mechanism to the desired tension.

7 Finalize the door adjustments

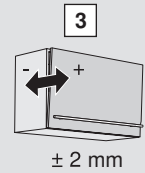
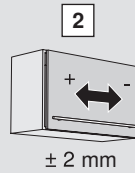
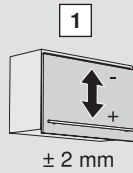
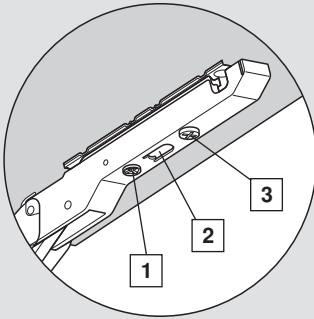

Use a POZI screwdriver to adjust cam adjustments for each of the three-dimensional adjustments.

8 Attach cover caps

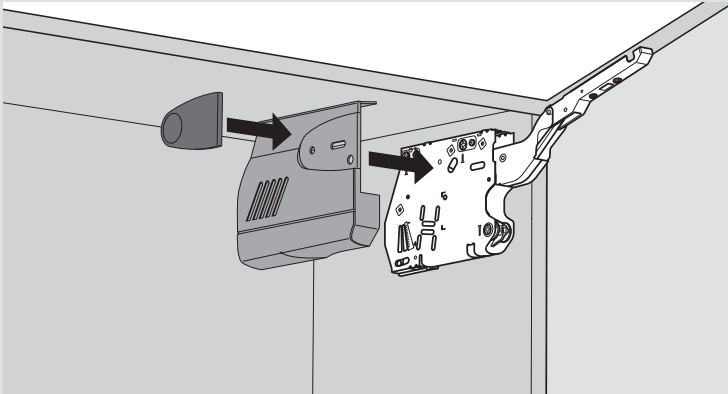

Snap the symmetrical cover caps on each cover plate. Place the left and right cover plates over the appropriate lift mechanisms and snap them in place.

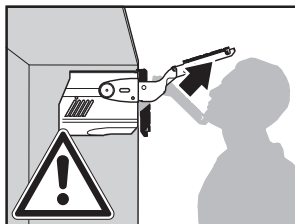

WARNING

Risk of injury from spring-loaded arm

- Do not push arm assembly down or leave in the down position
- Remove mechanism before installing or removing cabinet

1 Removing the covers

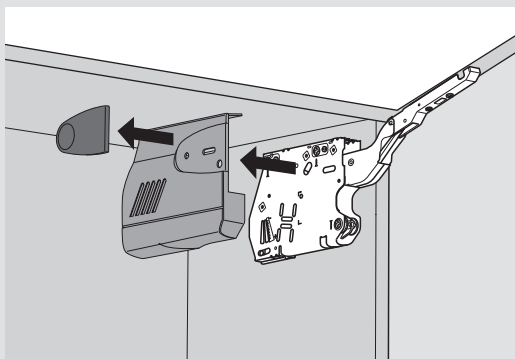

Remove the cover caps and cover plate.

2 Removing the door

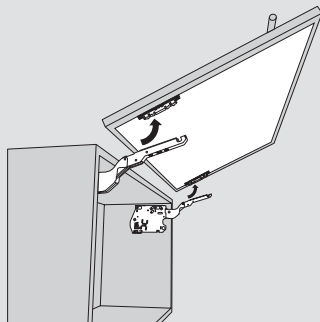
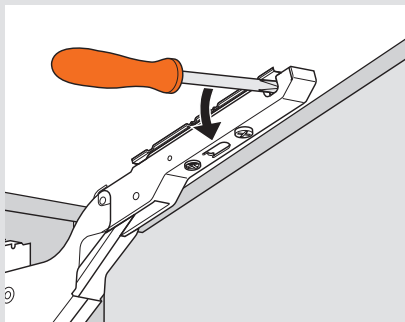

- Open the door. Use a screwdriver to disengage the CLIP mechanism of the lever arm from the mounting plate
- Support the door with one hand and repeat on the other side

Panel door clearance

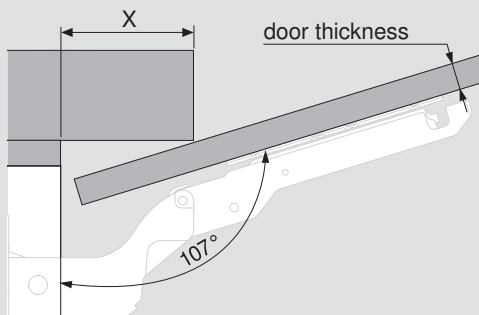

Door thickness	16	19	22	26
X	70	59	49	35

Inch		mm
1/32	.031	1
1/16	.063	1.5
3/32	.094	2
1/8	.125	3
5/32	.156	4
3/16	.188	5
7/32	.219	5.5
1/4	.25	6
9/32	.281	7
5/16	.313	8
11/32	.344	9
3/8	.375	9.5
13/32	.406	10
7/16	.438	11
15/32	.469	12
1/2	.5	13
17/32	.531	13.5
9/16	.563	14
19/32	.594	15
5/8	.625	16
21/32	.656	17
11/16	.688	17.5
23/32	.719	18
3/4	.75	19
25/32	.781	20
13/16	.813	20.5
27/32	.844	21
7/8	.875	22
29/32	.906	23
15/16	.938	24
31/32	.969	24.5
1	1	25.4

Blum, Inc.
 800-438-6788
 sales.us@blum.com
 blum.com