

QTL250
Sierra

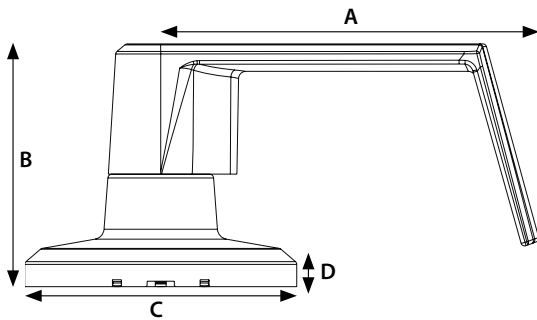

DIMENSIONS				
	A	B	C	D
Sierra	4.103"	2.635"	2.953"	.443"
	104.21mm	66.93mm	75mm	11.24mm
Summit	4.224"	2.663"	2.953"	.443"
	107.29mm	67.64mm	75mm	11.24mm
Slate	4.488"	2.728"	2.953"	.443"
	114mm	69.30mm	75mm	11.24mm

MECHANICAL LOCKS

Functions	ANSI		Description	Case Qty
QTL220 <i>Single Dummy</i>	—		For one side of door. Used for door pull or as matching inactive trim. No mechanical operation. Surface-mounted single dummy trim.	12
QTL230 <i>Passage</i>	F75		Both levers always unlocked and always free for immediate ingress & egress.	10
QTL240 <i>Privacy</i>	F76B		Turn-button locking. Can be opened from outside with small screwdriver. Turning inside lever releases turn-button. Inside lever is always free for immediate egress.	10
QTL250/251 <i>Entry/Office</i>	F82		Unlocked by key from outside when outside lever is locked by turn-button on inside lever. Inside lever always unlocked and available for immediate egress.	10
QTL260/261 <i>Classroom</i>	F84		Outside lever locked or unlocked by key. Inside lever is always unlocked and free for immediate egress.	10
QTL270/271 <i>Storeroom</i>	F86		Outside lever always locked. Entrance by key only. Inside lever always unlocked and free for immediate egress.	10