

BERTAZZONI PROFESSIONAL SERIES

48" 6-BURNER AND GRIDDLE, GAS DOUBLE OVEN

PRO48 6G GAS X

HIGHLIGHTS

- Bertazzoni's exclusive power burners in brass have independently operated flame rings giving maximum flexibility of operation from delicate low simmer to full power.
- The soft-motion oven door is specially designed and carefully balanced for easy opening and smooth closing with one hand.
- The telescopic oven rack provides more convenient oven access and easier handling of hot and heavy dishes.



FEATURES

Gas burners	6
Burner type	brass
Griddle	electric
Maintop	one piece stainless steel sheet
Burner controls	knobs
Knobs	metal finish
Grates	cast iron
Backguard	standard 4 inches
Gas safety device	thermocouple technology
One hand ignition	standard
Standard accessories	wok ring & simmer plate
Dual Power burner	750 - 18,000 Btu/h
Rapid burner	11,000 Btu/h
Semi-rapid burner	6500 Btu/h
Auxiliary burner	3400 Btu/h
Simmer rate	750 Btu/h
Griddle	1100 W, stainless steel/drip tray
Main oven	gas convection with gas infrared broiler
Main oven functions	traditional bake, convection bake, gas convection, broil, defrost/dehydrate, sabbath mode
Main oven volume	3.6 ft ³
Auxiliary oven	gas
Auxiliary oven functions	gas bake
Auxiliary oven volume	2.2 ft ³
Inner oven door	full-width triple glass
Oven equipment	2 telescopic glide shelf, 1 baking tray, 2 heavy gauge wire shelves, 1 grill trivet for tray
Legs	flap storage compartment, height-adjustable stainless steel legs

TECHNICAL SPECIFICATIONS

Voltage, frequency	120 V , 60Hz
Max Amp Usage, power rating	10 A - 1200 W
Certification	CSA
Warranty	2 years parts and labor

ACCESSORIES

Toe kick panel (TKS 48 X), flat island trim (IRF 48 X), side trim (ST 36 X)

Available LPG version PRO48 6G GAS X LP

MATCHING VENTILATION SOLUTIONS

Bertazzoni offers a variety of matching ventilation solutions for this range. Please check our website under the ventilation tab for a complete overview of all choices

COLORS OF ITALY

Color is an essential expression of Italian exuberance and artistic elegance. Bertazzoni celebrates these special qualities with seven color choices inspired by the wonderful produce of Emilia-Romagna, heartland of Italian food since Roman times.



STAINLESS STEEL NERO BLACK BIANCO PURE WHITE GIALLO YELLOW ARANCIO ORANGE ROSSO RED VINO BURGUNDY



TO COOK BEAUTIFULLY
WWW.BERTAZZONI.COM

INSTALLATION INSTRUCTIONS

PRO48 6G GAS X

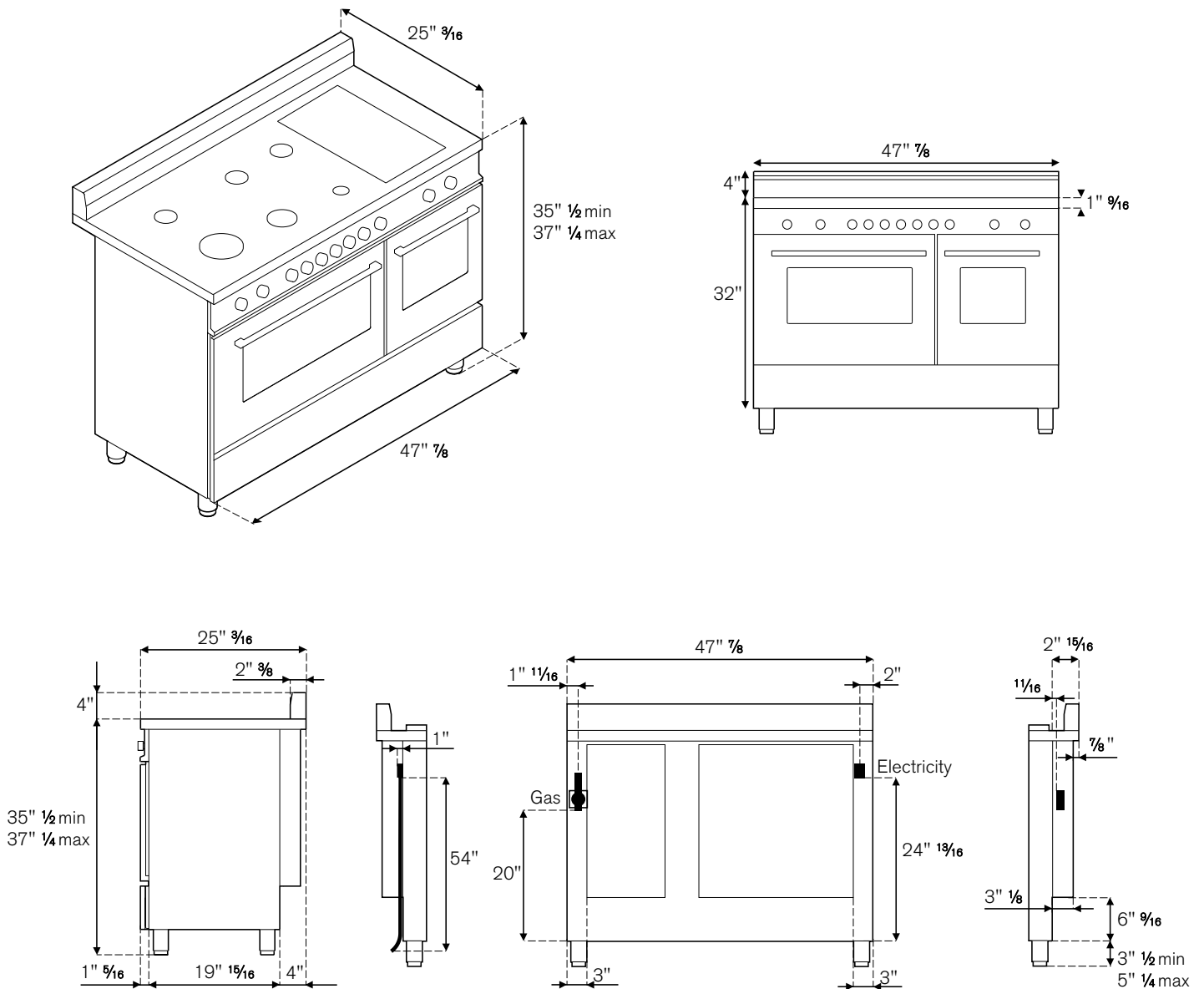

Bertazzoni recommends to operate the appliance after it has been installed in a cabinet. The kitchen cabinets shall be made of materials capable of withstanding temperatures at least 117°F (65°C) above room temperature in order to avoid possible damage to the cabinets during oven usage. For further installation instructions refer to the installation manual.

Disclaimer: while every effort has been made to insure the accuracy of the information contained in this brochure, Fratelli Bertazzoni reserves the right to change any part of the information at any time without notice.

Fratelli Bertazzoni, Bertazzoni and the winged wheel brand icon are registered trademarks of Bertazzoni Spa.