

# BE

**POWER EQUIPMENT**

## HOT WATER PRESSURE WASHER



### OPERATOR'S MANUAL

**COMMERCIAL**

**SERIES**

**INDUSTRIAL**

**SERIES**



BE Power Equipment Inc.

85.610.476  
03.2024

**INTRODUCTION**

Introduction & Identification Numbers ..... 3

**IMPORTANT SAFETY WARNINGS**

Important Safety Warnings & Symbols ..... 4

**GENERAL INFORMATION**

Pressure Washer Cooling Systems ..... 8

Fuel and Oil Types..... 9

**INSTALLATION INSTRUCTIONS**

Assembly ..... 10

**OPERATION**

Pre-Operation Safety & Inspection Procedures ..... 12

Start-Up Procedure ..... 13

Stop Procedure ..... 15

Detergent and General Operation ..... 16

**MAINTENANCE**

Specific Maintenance ..... 18

Maintenance Schedule ..... 20

Storage ..... 21

**TROUBLESHOOTING**

Troubleshooting Table ..... 22

**WARRANTY**

Warranty Statement ..... 24



**ATTENTION:** Read through the complete manual prior to the initial use of your pressure washer.

## INTRODUCTION & PRODUCT INFO

---

Congratulations on your purchase of a BE Power Equipment pressure washer. You can be confident that this pressure washer is constructed and tested with optimum performance and quality in mind.

Reading this manual will help get you the best results for set-up, operation, maintenance and avoid personal injury or damage to your machine. By knowing how best to operate this machine, you will be better positioned to show others who may also operate the unit.

All the information in this manual is based on the latest product information available at the time of printing. BE Power Equipment reserves the right to make changes at any time without notice or incurring any obligation.

### Owner/Operator Responsibility

The owner/operator must have a thorough understanding of the operation, maintenance and dangers associated with using this machine. It must be understood that it is ultimately up to the owner/operator to safely use this machine as outlined in this manual.

This manual is considered a part of the machine and needs to be kept in a safe location. If the machine is resold or given to someone else, this manual needs to be included.

### Product Registration

Please register your product online to get the maximum benefit from your warranty. Use the QR code below or register online at: [bepowerequipment.com/product-registration](http://bepowerequipment.com/product-registration)



It is recommended that you record the product identification numbers in this manual. These numbers are important to have on hand if you need to contact technical support (**1-866-850-6662**). The model and serial number can be found on the box and on a decal on the machine.

### PRODUCT IDENTIFICATION

Model Number: \_\_\_\_\_

Serial Number: \_\_\_\_\_

Date of Purchase: \_\_\_\_\_

Dealer Name: \_\_\_\_\_



**SAVE THESE INSTRUCTIONS - SAFETY RULES**

This is the safety alert symbol. It is used to alert you to potential personal injury hazards. Obey all safety messages that follow this symbol to avoid possible injury or death.

The safety alert symbol (▲) is used with a signal word (**DANGER, CAUTION, WARNING**), a pictorial and a safety message to alert you to hazards.

**DANGER** indicates a hazard that, if not avoided, will result in death or serious injury.

**WARNING** indicates a hazard that, if not avoided, could result in death or serious injury.

**CAUTION** indicates a hazard that, if not avoided, might result in minor or moderate injury.

**NOTICE** indicates a situation that could result in equipment or property damage.

**IMPORTANT SAFETY INSTRUCTIONS - SAVE THESE INSTRUCTIONS**

**WARNING** – When using this product, the following precautions should always be observed and adhered to.

1. Read all instructions before using the product.
2. To reduce the risk of injury, close supervision is necessary when a product is used near children.
3. Know how to stop the product and bleed pressures quickly. Be thoroughly familiar with the controls.
4. Stay alert. Watch what you are doing.
5. Do not operate the product when fatigued or under the influence of alcohol or drugs.
6. Keep operating area clear of other people.
7. Do not overreach or stand on unstable support. Instead, keep solid footing and balance at all times.
8. Follow the maintenance instructions specified in the manual.

**IMPORTANT WARNINGS**

**Failure to observe warnings will void the warranty or cause injury.**

1. Do not let the pressure washer overheat. Excess heat will cause serious damage (see page 8 for details).
2. Never run the unit without water. Running the pump dry will cause it to fail quickly.
3. Do not let the unit freeze. Frozen water in the pump will cause severe damage.
4. Always wear eye protection when operating the unit.
5. High-pressure spray can cause serious bodily injury or damage to soft material. Use with caution.
6. Never adjust the unloader to exceed the preset pressure. Premature wear, equipment failure, or injury may occur.

# SAFETY OVERVIEW

---

## PERSONAL SAFETY

**⚠ WARNING** - Always wear correct personal protection equipment because the high-pressure spray can launch debris at high velocity creating a risk of injury or damage.

- **ALWAYS** wear safety goggles for eye protection. Other protective equipment such as hearing protection, steel toe boots, safety apparel, work gloves and face shield are all recommended.
- **NEVER** pressure wash without closed-toe foot protection in case of accidental spray.
- **ALWAYS** be aware of where the spray gun is pointing and your environment
- **NEVER** point it at people or animals.
- **DO NOT** let children or unqualified people operate this machine.
- **DO NOT** use the machine when fatigued or under the influence of alcohol or drugs.

## GENERAL PRESSURE WASHER SAFETY

**⚠ WARNING** - RISK OF INJECTION OR SEVERE INJURY. KEEP CLEAR OF NOZZLE. DO NOT DIRECT DISCHARGE STREAM AT PERSONS. THIS EQUIPMENT IS TO BE USED ONLY BY TRAINED OPERATORS.

### **⚠ DANGER – High-Pressure Spray**

- **NEVER** point the gun at yourself, anyone else, or animals.
- The high-pressure water stream can cut through clothing, skin and underlying tissues leading to serious injury.
- If this type of injury occurs, **DO NOT TREAT AS A SIMPLE CUT. SEEK EMERGENCY MEDICAL ATTENTION IMMEDIATELY.** If you are using cleaning detergents, be prepared to tell the physician exactly what kind.
- Spray guns can have significant kickback. **ALWAYS** brace yourself and have firm footing when operating.
- **NEVER** attempt to repair high-pressure hose, fittings or gun. Always replace parts if they are leaking or damaged.
- **NEVER** bypass the trigger assembly. This is an important safety feature of the system.
- **NEVER** leave a running machine unattended.
- Use **CAUTION** even when the machine has been turned off. Pressure can be trapped in the pump and hose assembly and still inflict injury or damage. After turning the machine off, always squeeze the trigger to release any trapped pressure.
- **ALWAYS** ensure all component connections and fittings are securely fastened. High-pressure water can turn loose fittings or spray nozzles into projectiles causing injury or damage.
- **NEVER** look directly into the gun or high-pressure hose.
- **NEVER** place your hand in front of the spray nozzle to test pressure.

### **⚠ DANGER – ELECTROCUTION**

- **NEVER** spray near electric power source or cords.
- **NEVER** let run-off water pool and flow into power sources or cords.

### **⚠ WARNING – GENERAL SAFETY**

- **ONLY** use cold water to feed into the machine. Unless specifically instructed that the machine can use hot water.
- Check the work area to make sure it is clear of hazards and debris which can be thrown by pressure spray causing injuries or damage.
- **ALWAYS** be aware of surfaces that will become wet and may become slippery.
- **ALWAYS** have a secure grip of the gun and stable footing.

- **ALWAYS** ensure proper drainage to avoid water flooding into unwanted areas.
- **NEVER** operate machinery that is damaged or missing components.
- **NEVER** modify the machine in any way.
- **DO NOT** move the machine by pulling on the hoses or cords. Instead, use the handle on the frame to move the machine when needed.
- Use **CAUTION** when spraying soft materials such as plants or wood because the high-pressure spray can damage them quickly.
- Use **CAUTION** when spraying brittle materials such as glass, that may break apart, creating dangerous projectiles.
- Use only recommended accessories. **DO NOT** force or modify parts to fit.
- **ALWAYS** turn off the engine and disconnect the spark plug for any maintenance procedures.
- **NEVER** attempt to maintain the machine while it is operating. Moving parts and pressure can cause serious injuries.
- Keep machine out of the rain and elements.
- **ALWAYS** operate the machine on a level surface. It may seize if operated at an angle.

### **WARNING – CHEMICAL DETERGENTS/SOAPS**

- **ALWAYS** use detergents explicitly designed for a pressure washer.
- **NEVER** use any flammable, corrosive or acidic solutions.
- **NEVER** modify the chemical injector system.
- **ALWAYS** flush the system after using a detergent. Run the machine for at least two minutes with clean water to prevent detergent from drying and building up residue. If residue builds up, it may cause the chemical injector system to fail.
- **ALWAYS BE PREPARED** for an emergency involving detergents. Know exactly what the detergent contains. If an emergency occurs and a physician needs this information, Safety Data Sheets (**SDS**) are available and should be easily accessible.
- **ALWAYS** keep detergents away from children and animals.
- Keep an eyewash kit available in case of emergency.

### **GAS ENGINE SAFETY**

If your pressure washer has a gas engine, the engine will have its own manual. Thoroughly review and understand the engine manual.

### **DANGER – TOXIC FUMES**

- **ALWAYS** operate the machine outdoors in well-ventilated spaces.
- The emissions from the engine include the poisonous gas carbon monoxide. It is a colourless, odourless gas that will displace oxygen and be lethal in high enough concentrations.
- Symptoms of carbon monoxide poisoning include headache, fatigue, dizziness, nausea, confusion, vomiting, and seizures. If poisoning continues, unconsciousness and death will occur.
- At the first sign of any symptoms, **IMMEDIATELY** shut off the machine and move into a well-ventilated area and seek medical attention.
- Carbon monoxide is heavier than atmospheric air and will fill in low spaces first. Use **EXTREME CAUTION** when operating in low spaces such as trenches, tunnels or ditches.
- **NEVER** position the machine where the exhaust can go through windows, doors, ventilation or other access points that lead indoors or to confined areas.
- **NEVER** use a respirator as protection against carbon monoxide. The **ONLY** protection that can be relied on is a positive pressure fresh air supply system, such as a SCUBA system.

## SAFETY OVERVIEW

---

### **⚠ DANGER – FUEL RELATED FIRE AND EXPLOSIONS**

- Fuel and its vapours are highly flammable and explosive.
- Fire and explosion can cause severe burns and death.
- **NEVER** fill the fuel tank while the unit is running.
- **ALWAYS** turn the engine off and let it cool at least two minutes before removing fuel cap. Loosen the fuel cap slowly to relieve tank pressure.
- **ALWAYS** fill or drain the fuel tank outdoors.
- **DO NOT** overfill the tank. Leave an airspace in the neck of the fuel tank to allow it to breathe and for fuel expansion.
- **NEVER** have any spark or flame near the fuel, including cigarettes, open flame, pilot lights and other ignition sources.
- If fuel spills, wait until it evaporates completely. Move the unit to a new location, then wait at least two minutes before starting the engine.
- **NEVER** crank the engine with the spark plug removed and still in its boot.
- When transporting or putting the unit into storage, drain the fuel tank and carburetor and store the fuel in an airtight container. Then, move the fuel valve into the closed position.
- Never store fuel near any ignition source or hot surface.

### **⚠ CAUTION – HOT SURFACES**

- The muffler on the engine will heat up rapidly and can cause severe burns if touched.
- Heater coil exhaust will be hot and can cause burns to people and objects.
- Keep flammables away from the muffler.
- Keep at least a two meter clearance from the exhaust to prevent damaging other surfaces such as house siding and vehicles.
- The pump will also become hot during operation and should be avoided.
- After the pressure washer has been started, **DO NOT** touch any part of the pressure washer other than the on/off switch, handle, hose and gun.

### **⚠ CAUTION – RECOIL KICKBACK**

- Starter cord kickback (rapid retraction) can result in bodily injury.
- Kickback can pull your hand and arm back towards the engine faster than you can let go causing sprains, cuts, bruising and bone fractures.
- **NEVER** pull the starter cord without first relieving the spray gun pressure.
- When starting an engine, the best practice is to have the trigger squeezed to prevent pressure from building up in the system.
- Pull the starter cord until you feel resistance. Allow the cord to retract back and then pull the starter to avoid kickback and injury.

### **⚠ WARNING - BATTERY**

- This unit is equipped with a lead acid AGM Battery. It is a sealed battery system. If there is any signs of impact, deformation or moisture then do not use. It may be overcharged or damaged.
- **NEVER** open a sealed battery.
- **ALWAYS** keep sparks or any other source of ignition away from the battery. Especially during activation or charging.
- **ALWAYS** keep battery dry. Never spray with water.
- **NEVER** jump start the battery unless both batteries are of equal voltage and amperage.
- If you take the battery off the machine to recharge, you must ensure you have the correct charger otherwise damage to the battery may occur. Repeated incorrect charging practices can lead to an explosion.
- Recycle the battery in accordance with your local regulations.

**DO NOT OVERHEAT YOUR MACHINE**

Do not let your machine overheat. Failure to do so will result in damage, void warranty, or cause injury.

Gas engines are air-cooled. Always ensure that the machine is operated in a well-ventilated area where it can draw a steady supply of fresh air. If the engine overheats, it may shut down, rapidly burn oil, or result in component failure. The arrows below show an example of locations for air intake on an engine.

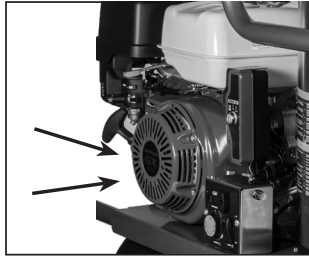

Pumps are cooled on the front end by having fresh water run into the pump, then spray out of the gun wand. To maintain the water flow, keep the trigger of the gun depressed to keep spraying out water. Do not let the machine run for more than 30 seconds without pressing down on the trigger. If the pump is left to overheat (not spraying water), it may experience thermal shock when cold water is introduced to the system once water is sprayed out again. This thermal shock can result in multiple component failures.

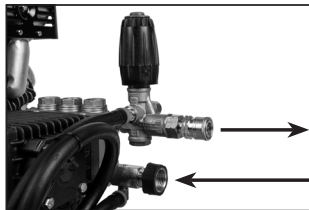

Most pumps are protected by a thermal valve. The thermal valve releases water if a pump starts to run too hot. It will prevent catastrophic heat failure. However, the pump may have suffered damage and need maintenance, repair, or replacement. The thermal valve may need to be replaced once it is triggered.

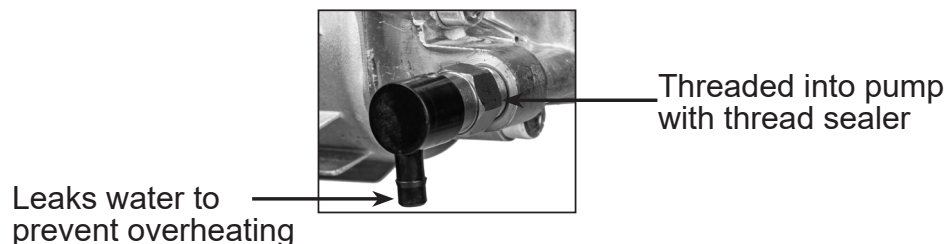

The back end of the pump is cooled by maintaining the proper level and quality of pump oil. Always check the oil level on the back of the pump by using the dipstick or sight gauge. Use 30w non-detergent oil if it needs to be added or replaced.

## FUEL AND OIL TYPES

### ENGINE FUEL TYPE

Use only regular unleaded gasoline rated at 86 octane or higher. The best fuel to use will have a 0% ethanol blend. However, the engine can use a fuel with an ethanol blend of up to 10%.

### ENGINE OIL TYPE

Use only SAE 10W30 motor oil for the engine. To check the oil, unscrew the engine dipstick. Then, wipe off the oil with a clean rag and dip it back into the engine. The oil should be well within the oil level markings.

Note\* the engine will have two oil caps. Only one will have a dipstick.

ENGINE TYPE	FUEL TANK CAPACITY	OIL CAPACITY
Powerase 420	6.7 L / 1.7 US Gal	1.1 L / 1.16 US qt
Honda GX200	3.1 L / 0.82 US Gal	0.6 L / 0.63 US qt
Honda GX390	6.1 L / 1.6 US Gal	1.1 L / 1.16 US qt
Vanguard 200	3.1 L / 0.82 US Gal	0.59 L / 0.6 US qt
Vanguard 400	5.7 L / 1.5 US Gal	0.94 L / 1.0 US qt

### PUMP OIL TYPE

For pressure washer pumps, use only SAE 30W non-detergent oil. Never use motor oil in your pressure washer pump because it will destroy the seals.

#### Never overfill the pump.

- If your pump has a sight glass, then fill halfway up to the middle of the red dot.
- If your pump has a dipstick, then fill to the mark on the dipstick.

### BURNER FUEL TYPE

- The fuel tank for the burner is the black plastic container located under the engine.
- **ONLY** use No.1 or No.2 Diesel or kerosene in the black plastic fuel tank.
- **DO NOT USE GASOLINE, CRANKCASE DRAININGS, OR OIL CONTAINING GASOLINE OR SOLVENTS.** Gasoline is more volatile and burners hotter than diesel. Using gasoline is extremely dangerous and will lead to component failures.
- **NEVER** put diesel into the Honda, Vanguard or Powerase engine.
- **DO NOT** let the fuel get completely used up before refilling. Running the fuel dry is hard on all the components and may lead to more difficult startups.

### CSA CERTIFIED MODELS

MODEL TYPE	BURNER FUEL TANK CAPACITY	FUEL TYPE	RATED MAX PSI	MAX TEMP RISE AT OUTLET
HW4015RA	37.8 L / 10 US GAL	No.1 or No.2 Diesel	4,000	37.8°C / 100°F
HW4013HC	37.8 L / 10 US GAL	No.1 or No.2 Diesel	4,000	37.8°C / 100°F
HW4013HG	37.8 L / 10 US GAL	No.1 or No.2 Diesel	4,000	37.8°C / 100°F

**⚠ CAUTION :** CSA certified for use with only No. 2 diesel or lighter oil. Using heavier oils voids CSA certification and the BE warranty policy. The use of these oils is subject to the acceptance of the Authority Having Jurisdiction.

### ADDITIONAL MODELS

MODEL TYPE	BURNER FUEL TANK CAPACITY	FUEL TYPE	RATED MAX PSI	MAX TEMP RISE AT OUTLET
HW2765HG	22.7 L / 6 US GAL	No.1 or No.2 Diesel	2,700	37.8°C / 100°F
HW2765VA	22.7 L / 6 US GAL	No.1 or No.2 Diesel	2,700	37.8°C / 100°F
HW4214VA	37.8 L / 10 US GAL	No.1 or No.2 Diesel	4,200	37.8°C / 100°F
HW4013HBG	37.8 L / 10 US GAL	No.1 or No.2 Diesel	4,000	37.8°C / 100°F

Your pressure washer will require some assembly. If you have any trouble with this process, please call our tech support department (**1-866-850-6662**) with your model number.

Unpack your pressure washer

- Remove all the components, including bags and manuals.
- Inspect components to make sure there is no visible damage.

### **ATTACH HANDLE**

1. Remove any plastic coverings that may be on the handle. Place handle onto frame by lining up the holes and using the provided nuts and bolts to secure it on the frame. Ensure the handle bar is pointing up.



**NOTE:** These diagrams are intended for general reference. As a result, they may not fully reflect the appearance of your product.

2. Insert the bolts through holes.
3. Insert colored quick connect spray nozzles, high-pressure hose, gun wand assembly into the spaces provided.



4. If needed, attach the provided detergent siphoning hose to the brass barb coming out of the pump near the high-pressure outlet. (Do not attach to the black plastic thermal relief valve barb.)
5. Assemble the gun wand. The trigger assembly will be threaded onto the wand. Hand tighten only. Plug the gun into the hose by pulling back on the sleeve of the quick connect fitting before inserting the plug.

# INSTALLATION INSTRUCTIONS

## HOSE CONNECTIONS

- **Quick connect fittings:** pull back the collar of the coupler, insert plug, and release the collar. Tug on fittings to confirm a secure lock.
- **Spray Nozzles:** To attach a spray nozzle to the end of the wand, pull back on the collar of the brass fitting. Insert the spray nozzle and release the collar. Tug on the nozzle to make sure it is secure. If it is loose, the high-pressure water will launch it out and may cause injury or damage.

Your pressure washer will come with several colored spray nozzles that will have different spray patterns and abilities.



0° Nozzle (Red)	Concentrated stream to break apart baked-on mud or dirt. Use with caution.
15° Nozzle (Yellow)	Narrow spray pattern that is aggressive and best used on hard surface to remove tough dirt.
25° Nozzle (Green)	General purpose spray pattern. Slightly wider, but still fairly aggressive.
40° Nozzle (White)	Wider spray pattern for large areas or softer surfaces.
Black Soaper Nozzle	Low pressure nozzle. This is the only nozzle that can be used with the chemical injector system.

## TO REMOVE A SPRAY NOZZLE:

1. Pull back collar on quick-connect coupler and pull the current spray tip off. Store the spray tips in the holder provided on the handle. Storing nozzles in the designated holder will help prevent any debris from clogging the tip.

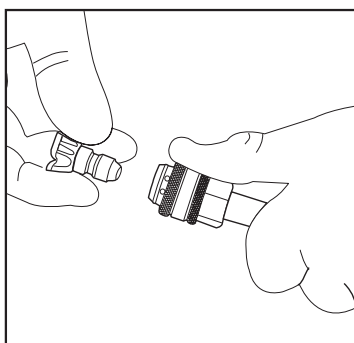



## PRE-OPERATION

1. Before operating the pressure washer, ensure you are familiar with all the warnings and safety recommendations.
2. Wear proper clothing and eye protection.
3. Always setup the machine where:
  - 3.1 It is on a level, non-combustible surface. If the machine is not level, it may not start or cause failures.
  - 3.2 There is sufficient ventilation.
  - 3.3 There are no signs of oil or gas leaks, including gas vapors.
  - 3.4 The machine is not exposed to rain, snow or freezing temperatures. These harsh conditions can lead to component failure causing damage or injury.
  - 3.5 It is no closer than the minimum distance of 2 meters to adjacent combustible materials while the machine is in operation.
4. Ensure that oil levels for the engine and pump are correct.
  - 4.1 Use 10W30 oil to fill the engine if needed.
  - 4.2 Use 30W non-detergent oil to fill the pump if needed.
5. If the pump has an oil cap dipstick, make sure it is the breathing oil cap instead of the sealed travel oil cap. If the sealed travel oil cap is left in, the pump will over pressurize and blow it out.
6. Inspect the overall condition of the unit. Make sure there are no fuel or oil leaks or damaged parts. If any leaks or damaged parts are detected DO NOT start the pressure washer until it is fixed.
7. Connect the high-pressure hose to the pump and the gun wand assembly to the other end of the hose.
8. Connect the garden hose to the pump. **NEVER** run without water.
  - 8.1 Ensure the inlet filter on the pump is present, intact, and clean before connecting the garden hose.

## WATER SUPPLY MUST BE SUFFICIENT TO SUPPLY THE PUMP ADEQUATELY.

Every pressure washer has a Gallons Per Minute (GPM)/ Liters Per Minute (LPM) rating that must be adhered to. If the pump does not get enough water, it will cavitate (starve for water). This will cause internal damage and pending failure.

To measure your water source GPM/ LPM, you will need a container that you know the exact size such as a 5-gallon/20-Liter bucket. When you're ready, start filling it from your water source while timing it for one minute. The amount of water in the 5-gallon/20-liter bucket after one minute is the GPM/LPM rating.

The water source GPM/ LPM should exceed the GPM/ LPM rating of the machine by one GPM or 4 LPM to account for any fluctuations from the water source.

The water source should have 20 to 60 PSI/1.38 to 4.1 BAR pressure going into the pump. Do not use a hose longer than 50ft/15m or less than 5/8" in internal diameter to the water source.

## PRIME THE PUMP WITH WATER

Once all the hoses are connected, turn on your water supply and hold down the spray gun's trigger. Let water flow through it until all the air bubbles are worked through, and there is a constant stream of water coming out the nozzle.

Insert the color spray nozzle that you plan to use. Make sure the nozzle is clean with no damage or blockages.

# OPERATING INSTRUCTIONS

## GAS ENGINE START PROCEDURE

### RECOIL START

1. Fill the fuel tank with gasoline. Use regular unleaded, 86 octane or higher that has no more than 10% ethanol blend.
2. Do not overfill the fuel tank. Always leave a space to allow the tank to breathe and the fuel to expand.
3. Set to full throttle. On all models the lever will be all the way LEFT.
4. Turn the fuel valve to the ON position. On the Honda and Powerase the fuel valve lever is moved all the way to the RIGHT. The Vanguard engine has it built into the throttle which needs to be all the way LEFT.
5. Activate choke if the engine is cold. On all models move the choke lever all the way to the LEFT.

· HONDA GX  
· POWEREASE



· VANGUARD

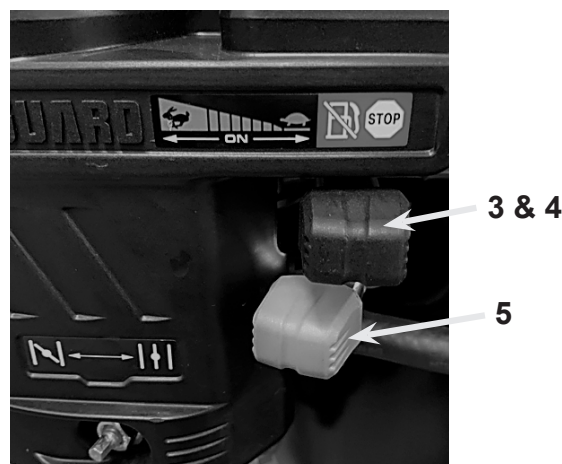

6. Put engine switch to the ON position. The Honda GX200 will have a switch on the side of the engine. The Honda GX390 and Powerase engine will have a keyed ignition that will need to be turned to the ON position. The Vanguard is in the ON position when it is set to full throttle.

· HONDA GX200



· HONDA GX390  
· POWEREASE 420



7. With one hand, squeeze the trigger of the spray gun trigger so the water is flowing. Brace yourself, then with the other hand, grip the recoil handle and slowly pull it out until you feel resistance. Pull briskly on the recoil. You may have to pull it several times before it starts running.
8. Once the engine has warmed up, disengage the choke lever by moving the lever to the right to smooth out the engine. If it stalls, then it needs to get warmer before the choke is turned off. Restart the engine, let it warm up, and then try turning the choke off again.

**Important Note:** The pressure washer has been designed to run at full throttle. If you lower the throttle then the load-to-power ratio between the engine and pump will be incorrect. This will cause undue strain on the system while pressure washing, causing parts to wear quicker and may lead to unsafe operating conditions.

## HOT WATER BURNER START/STOP PROCEDURE

### ELECTRIC START

For units that are equipped with an electric start engine.

1. Follow all the set ups already described up to the point of pulling the recoil.
2. Connect the battery cable (battery must be connected and charged to use electric start).
3. With one hand, squeeze the trigger of the spray gun so the water is flowing. With the other hand, turn the engine key to the 'ON' position to start the engine.
4. Once the engine starts, release the key.

· HONDA GX390



· VANGUARD



### HOT WATER BURNER START/STOP PROCEDURE

1. Fill the black fuel tank with Diesel or Kerosene (No.1 or No.2 grade)
2. The battery must be plugged in and fully charged to start the heater.
3. Once the engine is running, push the burner toggle switch to the ON position and adjust the thermostat to the desired temperature.

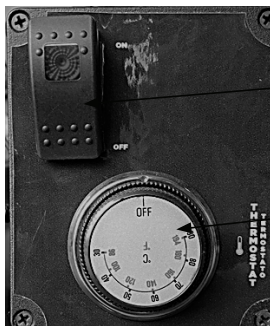

ON/OFF  
Toggle Switch

Thermostat



TACH/HOUR Meter

ON/OFF  
Toggle Switch

### NOTICE

Once the heater has been started, the water will begin heating up in about 20 seconds. It will reach maximum temperature within 2.5 minutes of continuous spraying through the gun. The burner will not fire when the trigger is released.

### ⚠ WARNING

The water temperature can become extremely hot during operation. Use caution when operating the spray gun.

### HOT WATER BURNER STOP PROCEDURE

1. To turn off, push the burner toggle switch to the OFF position.
2. Once the heater is off, squeeze the trigger and spray the water for three minutes to cool the heater coil and high pressure hose. Insufficient cool-down periods for the high pressure hose will cause excessive wear and eventual rupture of the hose.

### HOT WATER BURNER RESTART PROCEDURE

1. Follow the Stop / Start Procedures above to restart the machine.
2. If problem persists, consult troubleshooting guide or technical support.

# OPERATING INSTRUCTIONS

---

## GAS ENGINE STOP PROCEDURE

### ENGINE STOP PROCEDURE

1. Throttle down the engine.
2. While holding the spray gun trigger, turn off the engine.
  - The Honda GX200 will be a switch on the side of the engine.
  - The Honda GX390 and Powerease will need to have the key turned left to the OFF position.
  - The Vanguard engine off switch is built into the throttle. Move the lever all the way to the RIGHT to turn off the engine.
3. Turn the fuel valve to the OFF position.

**Emergency Stop:** Switch the engine to the OFF position immediately. This will stop the engine right away, but may trap pressure in the system, which may prevent restarts or the ability to remove the hose or spray gun.

1. Turn off the water source, and squeeze the trigger again to release pressure and water before disconnecting the hoses.
2. Drain the water out of the hoses before putting into storage.

· HONDA GX200



· HONDA GX390  
· POWEREASE



· VANGUARD



**CLEANING WITH DETERGENTS****NOTICE**

This feature is designed for use with mild detergents only. Since the cleaning solution travels through the heat exchanger coil, **DO NOT** use corrosives as they will cause extensive damage as well as pose a considerable safety hazard.

1. The black soaper nozzle must be installed on the spray wand. It is the only nozzle that will draw detergent through the pressure washer system.
2. Prepare detergent solution according to label directions. Never pump acids, alkaline, abrasive fluids or solvents through the unit. Due to the unknown and often corrosive characteristics of many detergents commonly used in the pressure washer cleaning industry, it is recommended to use only mild detergents with this unit.
3. Connect the detergent pick-up tube (and assembly) to the pump.
4. Fully immerse the detergent strainer end of the pick-up tube into the detergent solution.
5. To apply solution, squeeze trigger and begin spraying. You will be able to see the detergent move through the pick-up tube and then spray out the nozzle. It will take a few minutes for the detergent to work through the system before it is noticed coming out the spray nozzle.
6. Start spraying the lower portion of the surface being cleaned and move up, using long overlapping strokes. Applying from the bottom up helps avoid streaking and gives the detergent a chance to soak in and begin to breakdown the dirt.
7. Be careful to not let the detergent solution to dry on the surface. This may result in damaged surfaces. Avoid working on hot surfaces or in direct sunlight.
8. To rinse, release the spray gun trigger, then remove the black nozzle and replace with the green or white nozzle. It will take about 30 seconds to purge all the detergent from the system. For best rinsing results, start at the top and work down.
9. When done with the detergent system, always flush the system by siphoning clean water through the detergent pick-up tube while spraying for at least one minute. This helps prevent detergent from building up or causing corrosion and causing mechanical problems.

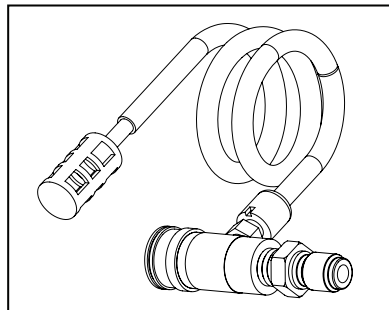

# OPERATING INSTRUCTIONS

## GENERAL OPERATION

### GENERAL PRESSURE WASHER OPERATION TECHNIQUES

1. Always follow safety practices as outlined.
2. Always begin spraying at a safe distance from the intended surface and move closer until the desired cleaning effect can be observed.
3. Generally, do not use a 90° spray angle. Instead, it is usually more effective to use a shallower angle so that the reflecting spray can be directed in a safe and controlled direction.
4. Holding down the trigger, move the wand side-to-side to clean the surface. Once you get a feel for how the cleaning performance behaves you will naturally find your rhythm.
5. Always be aware of what you are spraying and take greater care on fragile surfaces such as wood or glass to prevent damage.
6. Always remember to squeeze the trigger once every 30 seconds to flush the pump with cool water to prevent overheating.
7. If you have to stop washing for more than a few minutes, you should turn off the machine.
8. Do not tamper with the preset settings of the machine; understand user-operated controls before adjusting.

### PRESSURE WASHER PUMP & COIL SAVER TOOL

This tool utilizes compressed air to clear any remaining water from the pump and hot water coil in your pressure washer. To use the Pump & Coil Saver Tool, ensure your air compressor's regulator is set to a maximum of 60 PSI. Leave your hose and gun connected to your pressure washer, but remove the nozzle from the end of the wand. For hot water pressure washers, it is recommended that all water be removed from the pump and coil after every use. This will prolong their life and prevent possible freezing damage in cold weather. Follow the steps below to use the Pump and Coil Saver Tool:

1. Thread the blow out tool into the inlet of the pump.
2. Ensure the air compressor regulator is set to 60 PSI or less.
3. Connect air line from air compressor to blow out tool.
4. Hold trigger of pressure washer gun open.
5. (If applicable) squeeze bypass hose several times to help remove water from the unloader bypass system.
6. Once there is no more water coming out of the tip of the gun, disconnect the airline from the blow out tool, squeeze trigger of the pressure washer gun to relieve any remaining air pressure.

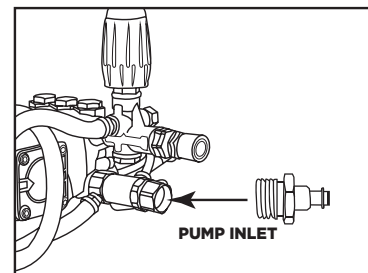

### ACCESSORIES

The machine typically comes with:

- 5 quick connect nozzles (0°, 15°, 25°, 40°, Soaper)
- a high pressure hose
- a high pressure gun/lance

These accessories are intended to be used with the machine. See page 5 for list of warnings and risks when using these accessories. See hang tag of machine for additional accessories intended for use with the machine.



**GASOLINE ENGINE**

Refer to the engine manual that came with your pressure washer for details. Routinely check:

1. Oil level and condition
2. Air filter
3. Spark plug
4. Watch for leaks

<b>ENGINE MAINTENANCE SCHEDULE</b>		
Engine Oil	Check	Every Use
	Replace	After the first 20 hours of operation. Then every 100 hours of use, or every 12 months, or if inspection shows oil is dirty, whichever comes first.
Air Filter	Check	Every Use
	Replace	When dirty or damaged.
Fuel Lines	Check	Every Use
	Replace	When damaged/leaking fuel.
Fuel Cap Filter	Check	Every Use.
	Replace	When unable to clean or if damaged.
Spark Arrestor (if applicable)	Check	Every 25 hours.
	Replace	When unable to clean or if damaged.
Spark Plug	Check	Every 100 hours.
	Replace	When unable to clean or adjust
Valve Clearance	Check	Every 300 hours.*
Idling RPM	Check	Every 300 hours.*
*Have serviced at an authorized service center.		

# MAINTENANCE

## PUMP MAINTENANCE

**PUMP:** Change the pump oil after the first 50 hours of operation. After the initial change, every 3 months or 250 hour intervals are recommended. If oil appears dirty or milky, changes may be required in greater frequency. **Use SAE 30 non-detergent pump oil** and fill only to the center of the oil sight glass.  
DO NOT overfill.

PUMP MAINTENANCE SCHEDULE	
Oil Condition	Inspect before every use
First oil change	25 hours
Then Change after	Every 250 hours of use, or every 12 months, or if inspection shows oil is dirty, whichever comes first.

If oil is milky in color, then water has leaked into the crankcase. Further inspections and repairs will be needed. This will include pump seals and ceramic plungers.

**NOZZLE:** Water flow through the spray nozzle will erode the orifice over time, making it larger. This will result in a reduction of pressure. Nozzles should be replaced whenever pressure is less than 85% of the maximum. The frequency of replacement will depend upon such variables as mineral content in the water and number of hours the nozzle is used. Every 3-6 months tends to be a standard interval for replacement.

**HEATER COIL:** After every use flush with cold water to cool the coils down. Then flush out all the water with the coil saver tool as described on Page 16. This will minimize scale build up.

Scale build-up in the coil results when the water is 'hard', which means it has calcium, magnesium and other dissolved minerals. The heating and cooling process will cause these minerals to solidify and bind to the inside of the coils. Left too long, the minerals will turn to scale and restrict water flow. Excessive scale build up will need to be removed with a coil cleaner solution.

Do not expose to rain or excessive moisture.

**HOSES AND SPRAY WAND:** Drain out water after every use. Store in a safe, dry location.

**FITTINGS:** Inspect for leaks and damage. Replace parts as needed.

### WATER INLET FILTER ON PUMP

1. Inspect before every use
2. Rinse clean when dirty
3. Replace when damaged or leaking

### DIESEL TANK DRAIN PROCESS

1. Shut off fuel valve
2. Disconnect fuel filter from supply fuel line
3. Run flexible fuel line into drainage container
4. Turn on fuel valve and allow to drain
5. If additional cleaning is required, unbolt fuel tank, remove, and clean with hot water & mild detergent
6. Once all residual water has dried, reinstall diesel tank and supply lines



**MAINTENANCE SCHEDULE**

<b>PROCEDURE</b>		<b>EACH USE</b>	<b>3 MONTHS</b>	<b>6 MONTHS</b>	<b>9 MONTHS</b>	<b>12 MONTHS</b>
Check engine oil level		X				
Change engine oil	*****		X	X	X	X
Check pump oil level		X				
Change pump oil	**		X	X	X	X
Oil leak inspection		X				
Fuel leak inspection		X				
Water leak inspection		X				
Hose inspection		X				
Water inlet screen inspection		X				
Check fuel filter			X	X	X	X
Replace fuel filter				X		
Inspect belts			X	X	X	X
Replace high pressure nozzle	***		X	X	X	X
Inspect fuel pump filter	*					X
Replace fuel nozzle	*					X
Check burner air adjustment			X	X	X	X
Check burner electrodes	*					X
Test water pressure	*		X	X	X	X
Test fuel pressure	*		X	X	X	X
Test water temperature	*		X	X	X	X
Descale coil	****					X
Drain diesel tank						X

- \* Must be performed by an authorized service technician.
- \*\* The pump oil must be changed after the first 50 hours of operation and then every 250 hours, 12 months, or when the oil is dirty on inspection. Whichever comes first.
- \*\*\* High pressure nozzle should be replaced whenever pressure drops to less than 85%.
- \*\*\*\* Scale build-up will vary with mineral content in the water and amount of usage. Descaling can range from weekly to yearly maintenance.
- \*\*\*\*\* The engine oil must be changed after the first 20 hours of operation and then every 100 hours or when the oil is dirty on inspection. Whichever comes first.

## STORAGE

---

Improper storage of the pressure washer may lead to failures that are not covered by warranty.

In general, cover the pressure washer and store it in a clean and dry location. Wipe off any dirt or water.

### **⚠ WARNING - RISK OF FIRE**

Do not put machine away while still hot, allow for sufficient cooling time.

### **⚠ WATER – FREEZING WARNING**

Leaving water in the pump, coil or accessories can result in damage if the water freezes. Water will expand when it turns to ice. The resulting force will cause ruptures and crack brass fittings, valves, and seals requiring complete replacements (not warrantable).

Using the coil saver tool as described on page 16 will remove the water from the system and is a highly recommended first step. Further steps include:

1. Drain all the hoses and spray gun assembly.
2. If the unit is going to be stored for a extended period, or if there is any chance the pressure washer will be exposed to freezing temperatures, then plumbing/RV anti-freeze must be cycled through the pumps water ways.
3. We recommend using BE Power Equipment Pump Saver Anti-Freeze. It has a specially designed cap to thread right onto the garden hose fitting of the pump. (Part number 85.490.046, contact your local dealer).
4. To apply, first ensure the engine and fuel valve are in the OFF position.
5. Remove the seal under the bottle cap. Thread the bottle onto the garden hose fitting on the pump and open the valve on the cap. Squeeze the bottle to force the anti-freeze into the pump. You can also pull the recoil to cycle the anti-freeze solution through the pump. Continue until it comes out of the high-pressure hose fitting. At this point, anti-freeze is protecting all the internal water chambers of the pump.
6. The best defense against freezing is to store the pressure washer in a warm location that will not be exposed to freezing temperatures.

### **⚠ GASOLINE ENGINE FUEL SYSTEM WARNING**

Gasoline degrades overtime and will leave solid residues if it dries out in your fuel system. This will clog the fuel system and result in failure to start the machine (not warrantable).

1. Fuel degrades quicker the more it is exposed to air, and the greater the ethanol percentage blend.
2. Fuel stabilizer is strongly recommended to slow down the degradation process of fuel. Best practice is to mix the fuel stabilizer in the fuel storage container.
3. If the unit will not be used within 30 days, then drain all the fuel from the tank and carburetor.
  - 3.1 Use fuel stabilizer in the tank to mix with the fuel.
  - 3.2 To drain the fuel, have a container ready to catch the fuel.
  - 3.3 Use a wrench to loosen the bottom bolt of the carburetor and let all the fuel pour into the container. Once it stops, tighten the bolt. The fuel stabilizer that was put in the tank earlier will help prevent any residue fuel from drying into a hard residue.
  - 3.4 Open the fuel valve of the engine.
  - 3.5 When storing gasoline, always use an airtight jerry can and fuel stabilizer for best results. The best practice is to store fuel for no more than a year before using it.

SYMPTOM	PROBABLE CAUSE	REMEDY
Engine will not start	Various engine problems	Refer to the Engine Manual accompanying your unit.
	Unit components are frozen.	Allow to thaw. If any part of the unit becomes frozen; excessive pressure may build up in the unit. This can cause the unit to burst, resulting in possible serious injury to the operator or bystanders.
No discharge at nozzle when trigger mechanism is squeezed.	Inadequate water supply.	Ensure hose is 3/4" diameter and incoming water supply is turned on. Ensure the water is turned all the way on.
Low or fluctuating pressure.	Kink in water inlet hose.	Remove kink.
	Water inlet screen obstructed.	Remove screen, clean, or replace.
	Pump sucking air. (Prime eliminated)	Tighten all water intake connections Eliminate leaks in intake line.
	Incorrect nozzle installed on gun.	Insert high pressure nozzle.
	Obstructed or worn spray nozzle.	Remove, clean or replace.
	Damaged or obstructed valve assy. on pump.	Remove, clean or replace.
	Pump packings worn.	Replace packings.
	Unloader/bypass valve not operating correctly.	Repair or replace.
Water is leaking at safety relief valve.	Unloader malfunction.	Detect and correct unloader problem.
	Pressure switch malfunction.	Detect and correct pressure switch problem.
	Safety relief valve is defective.	Replace safety relief valve. NEVER run unit without safety relief valve. Doing so can cause an explosion!
Oil appears milky or foamy.	Water got into the oil through cracked pistons or worn oil seal.	Drain old oil. Replace pistons or oil seal as needed. Fill with new oil.
Oil leaking from unit.	Worn seals or o-rings.	Consult customer service.
Detergent will not siphon	Detergent strainer is not completely submerged in detergent solution.	Check, submerge if necessary.
	Detergent strainer obstructed.	Inspect, clean, or replace.
	Detergent hose cut, obstructed or kinked.	Inspect, clean, or replace.
	Detergent adjusting knob turned to closed position.	Open adjusting knob. Refer to "Cleaning with Detergents".
	Nozzle assembly is plugged.	Clean or replace.
Water flows back into detergent container.	Ball & spring in Venturi reversed, missing, or corroded.	Remove, clean, or replace.
Water flows from the nozzle when the trigger gun is locked in the "OFF" position	Trigger gun is malfunctioning.	Replace.
Blower motor will not run. (Burner will not ignite without blower running)	Burner/Blower motor malfunction.	Repair or replace.
	Belt broken or slipping on generator.	Adjust or replace as necessary.

# TROUBLESHOOTING

Blower runs, but burner will not ignite.	Switch is not in "Burner" position.	Check switch position.
	Thermostat knob is OFF.	Check thermostat knob position.
	Out of fuel.	Refuel.
	Gun trigger is closed/not pressed.	Press down on gun trigger.
	Detergent valve is open, but detergent hose is not completely submerged in solution. (This causes safety devices to shut down burner.)	Close valve, or completely submerge clear vinyl hose into detergent solution.
	Pressure switch override.	Pressure should be over 375 PSI
	No voltage.	Consult Service Department.
	Fuel pump sucking air.	Tighten all fuel intake connections. Eliminate leaks in intake line.
	Poor or improper fuel supply.	Check fuel to ensure it is correct. Drain tank and filter if necessary and refill with proper fuel.
Blower runs, but burner will not ignite.	Dirty or clogged fuel filter or fuel water separator.	Drain or replace as necessary.
	Low fuel pump pressure.	Check fuel pump pressure, adjust or replace as necessary.
	Fuel pump inoperative.	Check pressure, replace if necessary.
	Flexible coupler broken.	Replace.
	Fuel solenoid valve failure.	Replace.
	Dirty or clogged fuel nozzle.	Replace fuel nozzle.
	Improper burner air adjustment.	Adjust.
	Faulty ignition module.	Repair or replace. Consult Customer Service.
Burner runs erratically.	Water in the fuel.	Drain fuel filter/water separator. Drain fuel tank, and replace with clean fuel.
	Dirty fuel nozzle.	Replace.
	Fuel pump malfunctioning.	Replace.
Blower runs, burner ignites but will not heat.	Thermostat knob is OFF.	Check thermostat knob position.
	Detergent valve is open, but detergent hose is not completely submerged in solution. (This causes safety devices to shut down burner.)	Close valve, or completely submerge vinyl hose into detergent solution.
	Poor or improper fuel supply.	Check fuel to ensure it is correct. Drain tank and replace filter if necessary and refill with proper fuel.
	Dirty or clogged fuel filter or fuel water separator.	Drain or replace as necessary.
	Low fuel pump pressure.	Check fuel pump pressure, adjust or replace if needed.
Blower runs, burner ignites but will not heat.	Dirty or clogged fuel nozzle.	Replace fuel nozzle.
	Improper burner air adjustment setting.	Adjust the setting.
Blower runs, burner ignites but will not heat.	Scale build up in heat exchanger coil.	Consult Customer Service.
	Low on fuel.	Refuel. If white smoke persists, consult Customer Service.
Burner discharges white smoke.	Excessive air supply.	Adjust air flow.
	Insufficient air supply.	Adjust to ensure air flow is sufficient.
Burner discharges black smoke.		



BE Power Equipment Inc. warrants to the original retail purchaser that our new products are free from defects in material and workmanship for the time-frames set forth. If a defect is found in a BE Power Equipment product within the limitations outlined in this warranty statement, BE Power Equipment, at its sole discretion, will repair, replace, or credit the product.

The warranty coverage begins on the date of the retail purchase by the end-user. Valid proof of purchase must be presented with the warranty claim.

This warranty is limited to defects that occurred during regular operational use. It does not cover failures due to lack of maintenance, negligence, abuse, misuse, including, but not limited to, freezing damage, alterations, chemical deterioration, scale buildup, rust, thermal shock, thermal expansion, transportation damage, oil changes, valve adjustments, fuel system maintenance, or the use of incorrect parts. Furthermore, using the wrong fuel, water, or power supply is considered a form of misuse.

This warranty does not cover normal wearing items such as O-rings, valves, seals, filters, spark plugs, or packings. These are normal wearing items and should be factored into your regular maintenance schedule.

The warranty herein is in lieu of all other warranties, express or implied, including any implied warranty of fitness for a particular purpose. BE Power Equipment does not authorize any of its dealers, service centers, agents, employees, or any other party to expand, extend, or modify the scope of this warranty in any manner on behalf of BE Power Equipment.

BE Power Equipment expressly disclaims liability for injuries to persons or property, or for incidental damages, rental loss, time loss, transportation costs, or consequential damages. It is the buyer's responsibility to ensure the correct installation, application, and use of the product purchased.

## **HONDA ENGINE WARRANTY**

Honda requires their warranty claims to be evaluated and processed at their respective authorized service centers. Locations can be found on their respective website.

## **REGISTERED PRODUCT EXTENDED WARRANTY**

BE offers an extended warranty on its products upon registration on the website. To qualify for the extended warranty, products must be registered within 90 days of purchase. This extended warranty does not apply to Honda engines; it is your responsibility to follow and adhere to the Honda warranty processes and procedures. BE retains sole discretion in determining whether the failure results from a manufacturing defect or workmanship and is the cause of premature failure.

## **PRODUCT REGISTRATION**

Product registration form can be found at: [bepowerequipment.com/product-registration](http://bepowerequipment.com/product-registration)

## **WARRANTY PROCEDURE**

Contact the BE Technical Service department at 1-866-850-6662 or EMAIL us ([servicecenter@bepressure.com](mailto:servicecenter@bepressure.com)) with the following information:

- Model/part number
- Serial number (if applicable)
- Copy of the original purchase receipt
- Detailed description of the failure
- Any additional relevant details or photos pertinent to the situation

## **AUTHORIZED "BE" SERVICE CENTERS**

Authorized BE service centers can be found at: [bepowerequipment.com/service-centers](http://bepowerequipment.com/service-centers)



# WARRANTY

## WARRANTY TIMELINES COMPREHENSIVE BUMPER TO BUMPER WARRANTY

ENGINES AND MOTORS	STANDARD WARRANTY	REGISTERED EXTENDED WARRANTY
HONDA GX	3 YRS Through Honda	N/A
VANGUARD	3 YRS	5 YRS
KOHLER	3 YRS	5 YRS
POWEREASE GAS ENGINES	3 YRS	5 YRS
POWEREASE ELECTRIC MOTORS	1 YR	5 YRS
BALDOR ELECTRIC MOTORS	3 YRS	5 YRS
TECHTOP ELECTRIC MOTORS	3 YRS	5 YRS

PRESSURE WASHERS	STANDARD WARRANTY	REGISTERED EXTENDED WARRANTY
WORKSHOP SERIES	1 YR	5 YRS
COMMERCIAL SERIES	3 YRS	5 YRS **Excluding Honda Engines
INDUSTRIAL SERIES	3 YRS	5 YRS **Excluding Honda Engines

ACCESSORIES	STANDARD WARRANTY	REGISTERED EXTENDED WARRANTY
ALL ACCESSORIES	1 YR	N/A

# BE

**POWER EQUIPMENT**

IF YOU NEED ASSISTANCE WITH THE ASSEMBLY OR OPERATION OF  
YOUR PRESSURE WASHER, PLEASE CALL 1-866-850-6662  
OR VISIT OUR WEBSITE:

**BEPOWEREQUIPMENT**

**.COM**