

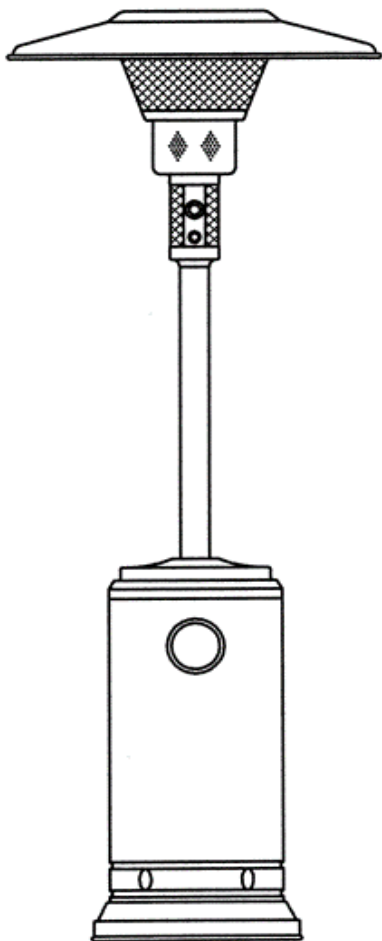

OUTDOOR COMMERCIAL PATIO HEATER

BURN-2400-BRZ
BURN-2400-BLK
BURN-2650-SS





DANGER

If you smell gas:
1. Shut off gas to the appliance.
2. Extinguish any open flame.
3. If odor continues, keep away from the appliance and immediately call your gas supplier or fire department.

WARNING

Do not store or use gasoline or other flammable vapors and liquids in the vicinity of this or any other appliance. An LP-cylinder not connected for use shall not be stored in the vicinity of this or any other appliance.

WARNING: For Outdoor Use Only

 DANGER	CARBON MONOXIDE HAZARD This appliance can produce carbon monoxide which has no odor. Using it in an enclosed space can kill you. Never use this appliance in an enclosed space such as a camper, tent, car or home.
	

WARNING

Improper installation, adjustment, alteration, service or maintenance can cause property damage, injury or death. Read the installation, operation and maintenance instructions thoroughly before installing or servicing this equipment.

Precaution!

The Powder Coating paint process has become the most common widely used application in the outdoor furniture category. Unfortunately powder coating is extremely sensitive to Humidity and Moisture. A simple process to protect your furniture, especially flat surfaces is to apply a simple coat of good quality car wax prior to using. If this process is done every few months it will protect your furniture for years to come.

ANS Z83.26:2020 Ed.3 • CSA 2.37:2020 Ed.3 Gas-Fired Outdoor Infrared Patio Heaters

ATTACH YOUR RECEIPT HERE

Serial Number _____ Purchase Date _____





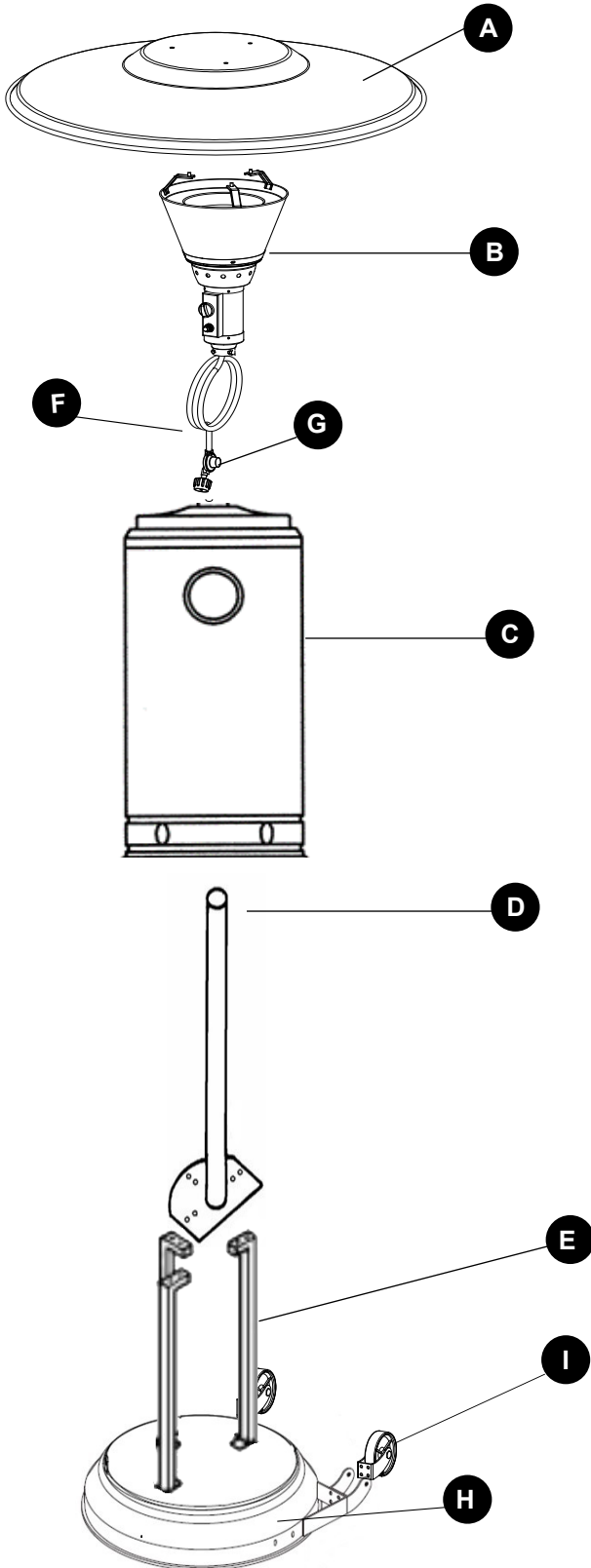

Questions, problems, missing parts? For small parts please call 1-888-775-1330 for assistance , 8 a.m. - 4 p.m., MST, Monday - Friday.. For damaged product, you may have to return to the retailer.

PACKAGE CONTENTS

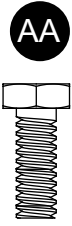

PART	DESCRIPTION	QUANTITY
A	Reflector Panel	1
B	Burner Head Assembly	1
C	Cylinder Housing	1
D	Post	1
E	Support Brackets	3
F	Gas Hose	1
G	Regulator	1
H	Base with Weighted Plate	1
I	Wheel Kit	2

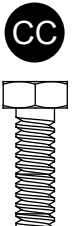
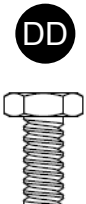
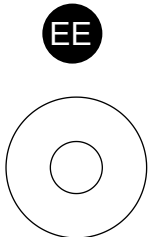
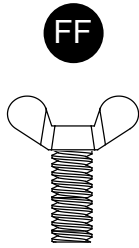
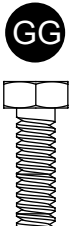
HARDWARE CONTENTS

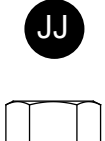
 M8 x 15 mm Bolts Qty. 3	 M6 Nut Qty. 16	 M6 x 35mm Bolts Qty. 6	 Stainless Steel Bolt Qty. 4	 Φ8 Washer Qty. 6	 M6x12mm Screws Qty. 3	 M6 x 15 mm Bolts Qty. 16
 M6 Flange Nut Qty. 6	 M8 x 45mm Bolt Qty. 2	 M8 Nut Qty. 2				

SAFETY INFORMATION

Please read and understand this entire manual before attempting to assemble, operate or install the product.

This manual contains important information about the assembly, operation and maintenance of this patio heater. General safety information is presented in these first few pages and is also located throughout the manual. Keep this manual for future reference and to educate new users of this product. This manual should be read in conjunction with the labeling on the product. Safety precautions are essential when any mechanical or propane-fueled equipment is involved. These precautions are necessary when using, storing, and servicing this item. Using this equipment with the respect and caution demanded will reduce the possibilities of personal injury or property damage. The following symbols shown below are used extensively throughout this manual. Always heed these precautions, as they are essential when using any mechanical or fueled equipment.

DANGER

Failure to comply with the precautions and instructions provided with this heater can result in death, serious bodily injury and property loss or damage from hazards of fire, explosion, burn, asphyxiation, and/or carbon monoxide poisoning. Only persons who can understand and follow the instructions should use or service this heater.

DANGER

FOR YOUR SAFETY

If you smell gas:

1. Shut off gas to the appliance.
2. Extinguish any open flame.
3. If odor continues, keep away from the appliance and immediately call your gas supplier or fire department.

 **SAFETY INFORMATION**

 **DANGER**

- **EXPLOSION - FIRE HAZARD**
- Keep solid combustibles, such as building materials, paper or cardboard, a safe distance away from the heater as recommended by the instructions.
- Provide adequate clearances around air openings into the combustion chamber.
- Never use the heater in spaces that do or may contain volatile or airborne combustibles, or products such as gasoline, solvents, paint thinner, dust particles or unknown chemicals.
- During operation, this product can be a source of ignition. Keep heater area clear and free from combustible materials, gasoline, paint thinner, cleaning solvents and other flammable vapors and liquids. Do not use heater in areas with high dust content. Minimum heater clearances from combustible materials: three (3) feet from the sides and two (2) feet from the top.

 **DANGER**

- **CARBON MONOXIDE HAZARD**
- This heater is a combustion appliance. All combustion appliances produce carbon monoxide (CO) during the combustion process. This product is designed to produce extremely minute, non-hazardous amounts of CO if used and maintained in accordance with all warnings and instructions. Do not block air flow into or out of the heater.
- Carbon Monoxide (CO) poisoning produces flu-like symptoms, watery eyes, headaches, dizziness, fatigue and possibly death. You can't see it and you can't smell it. It's an invisible killer. If these symptoms are present during operation of this product get fresh air immediately!
- For outdoor use only.
- Never use inside house, or other unventilated or enclosed areas.
- This heater consumes air (oxygen). Do not use in unventilated or enclosed areas to avoid endangering your life.

 **DANGER**

- **EXPLOSION - FIRE HAZARD**
- Never store propane near high heat, open flames, pilot lights, direct sunlight, other ignition sources or where temperatures exceed 120°F.
- Propane vapors are heavier than air and can accumulate in low places. If you smell gas, leave the area immediately.
- Never install or remove propane cylinder while heater is lighted, near flame, pilot lights, other ignition sources or while heater is hot to touch.
- This heater is red hot during use and can ignite flammables too close to the burner. Keep flammables at least 3 feet from sides and 2 feet from top. Keep gasoline and other flammable liquids and vapors well away from heater.
- Store the propane cylinder outdoors in a well ventilated space out of reach of children. Never store the propane cylinder in an enclosed area (house, garage, etc.). If heater is to be stored indoors, disconnect the propane cylinder for outdoor storage.

 **SAFETY INFORMATION**

 **WARNING**

We cannot foresee every use that may be made of our heaters.
Check with your local fire safety authority if you have questions about heater use.
Other standards govern the use of fuel gases and heat producing products for specific uses. Your local authorities can advise you about these.
If no local codes exist, follow National Fuel Gas Code, ANS Z223.1. In Canada, installation must conform to local codes. If no local codes exist, follow the current National standards of CANADA CAN/CGA-B 149.2.

 **WARNING**

California Proposition 65
Combustion by-products produced when using this product contain chemicals known to the state of California to cause cancer, birth defects, and other reproductive harm.

 **WARNING**

BURN HAZARD

- Never leave heater unattended when hot or in use.
- Keep out of reach of children.

 **WARNING**

Do not store or use gasoline or other flammable vapors and liquids in the vicinity of this or any other appliance. An LP-cylinder not connected for use shall not be stored in the vicinity of this or any other appliance.

 **WARNING**

Improper installation, adjustment, alteration, service or maintenance can cause property damage, injury or death. Read the installation, operation and maintenance instructions thoroughly before installing or servicing this equipment.

 **WARNING**

Certain materials or items, when stored under the heater, will be subjected to radiant heat and could be seriously damaged.

SAFETY INFORMATION

WARNING

- This product is fueled by propane gas. Propane gas is invisible, odorless, and flammable. An odorant is normally added to help detect leaks and can be described as a “rotten egg” smell. The odorant can fade over time so leaking gas is not always detectable by smell alone.
- Propane gas is heavier than air and leaking propane will sink to the lowest level possible. It can ignite by ignition sources including matches, lighters, sparks or open flames of any kind many feet away from the original leak. Use only propane gas set up for vapor withdrawal.
- Store or use propane gas in compliance with local ordinances and codes or with ANS/NFPA 58. Turn off propane when not in use.

CAUTION

SERVICE SAFETY

- Keep all connections and fittings clean. Make sure propane cylinder valve outlet is clean.
- During set up, check all connections and fittings for leaks using soapy water. Never use a flame.
- Use as a heating appliance only. Never alter in any way or use with any device.

WARNING

- Alert children and adults to the hazards of high surface temperatures. Stay away from these surfaces to avoid burning skin or igniting clothing.
- Carefully supervise young children when in the vicinity of the heater.
- Do not hang clothing or any other flammable materials from the heater, or place on or near the heater.
- Replace any guard or protective device removed for servicing the appliance prior to placing back in service.
- Installation and repair should be done by a qualified service person. The heater should be inspected before use and annually by a qualified service person. More frequent cleaning may be required as necessary. It is imperative that the control compartment, burners, and circulating air passageway of the appliance be kept clean.

PREPARATION

Before beginning assembly of product, make sure all parts are present. Compare parts with package contents list and hardware contents above. If any part is missing or damaged, do not attempt to assemble the product. Contact customer service for replacement parts.

Estimated Assembly Time: 60 minutes

Tools Required for Assembly (not included): Phillips Screwdriver and Leak Detection Solution.

ASSEMBLY INSTRUCTIONS

STEP 1

1.A) Assemble both wheel brackets to the base with 8pcs M6X15 bolt (GG) and 8pcs M6 Nut (BB)

1.B) Assemble the wheels to the brackets with 1pc M8X45 bolt (II), and M8 Nut (JJ) (see step 2). Assemble the other wheel in the same way.

Wheel assembly completed as shown in figure 1.

Hardware Used

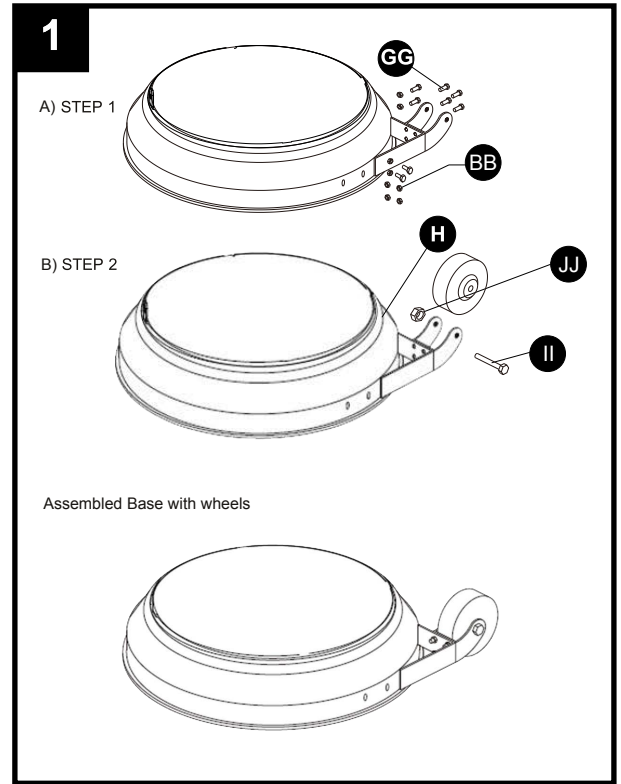
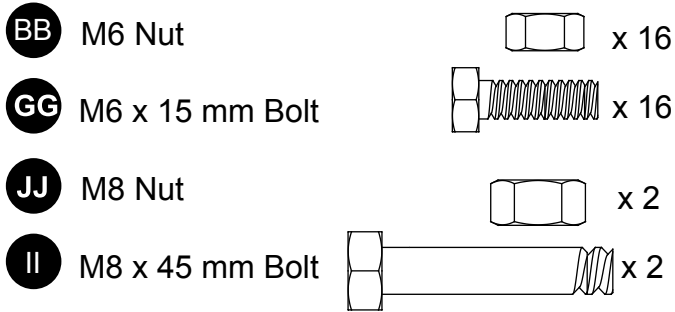

STEP 2

Attach the 3 vertical support brackets(E) to the base(H) using 3 bolts M8 X 15(AA) + 3Φ8 washers

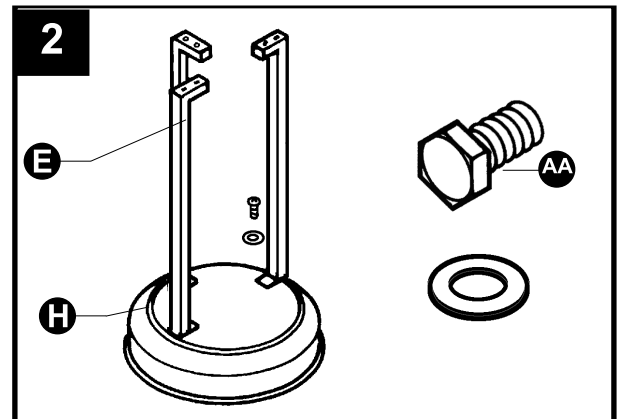

STEP 3

Fasten post(D) to the vertical support brackets(E) with 6 M6 X 35(CC) bolts and 6 M6 Flange nuts(HH)

STEP 4

Slide cylinder housing(C) on post(D)

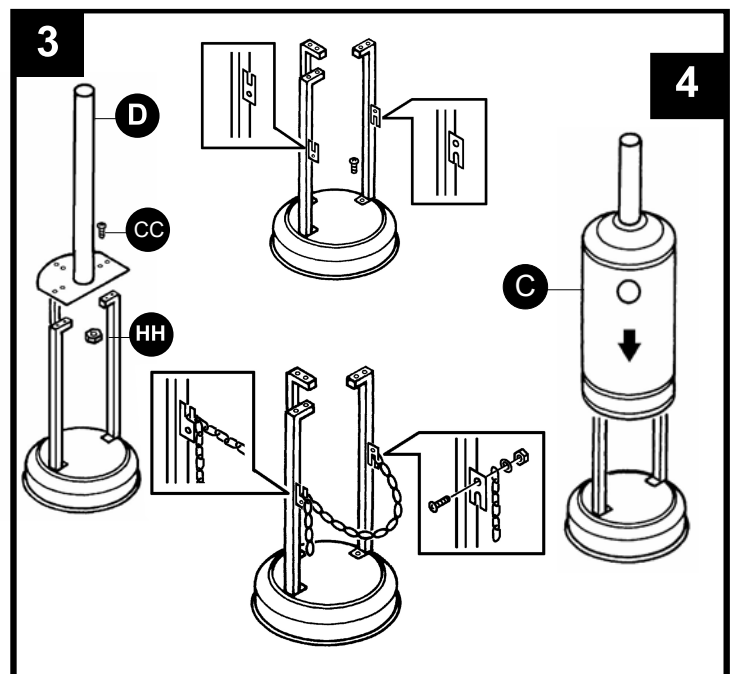

ASSEMBLY INSTRUCTIONS

STEP 5

Remove the 4 stainless steel bolts(DD) from the coupler of the burner head assembly(B)

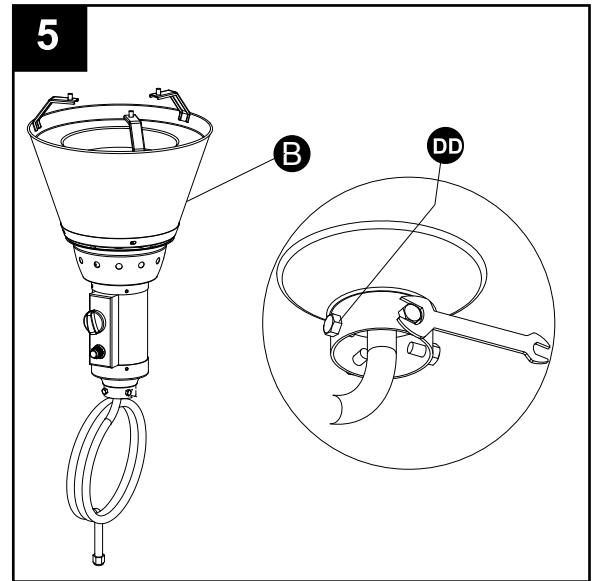

STEP 6

Run the hose(F) and regulator(G) down the post(D) and sit the burner head assembly(B) on the post.

Once lined up, use the 4 stainless steel bolts(DD) to attach the burner head(B) to the post(D)

Note: The control knob on head assembly (B) should be above the decal on post (E).

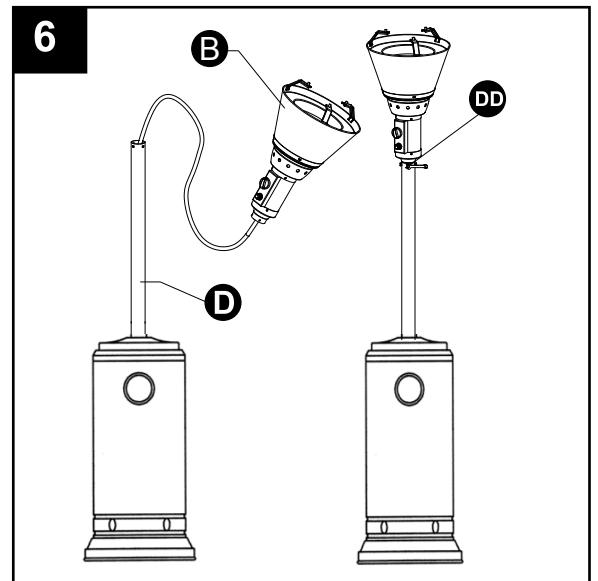

STEP 7

Place 3 washers(EE) on top of the burner reflector brackets.

Line up the 1 piece reflector panel(A) with the 3 burner reflector brackets and tighten using the 3 winged bolts(FF)

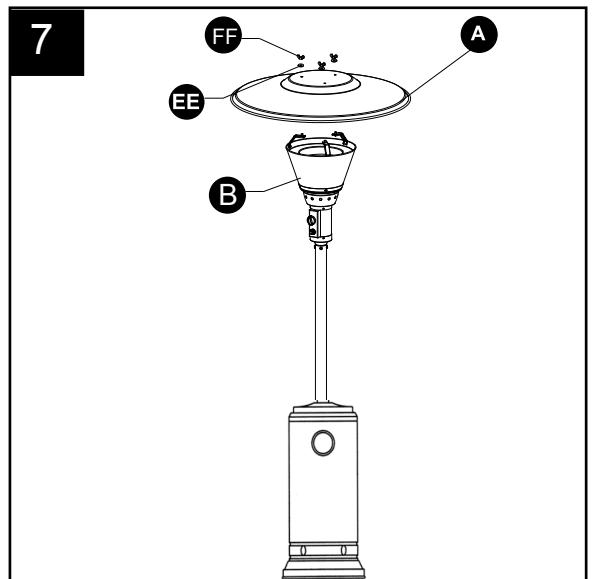

ASSEMBLY INSTRUCTIONS

STEP 8

Slide cylinder housing upwards.

Screw gas hose (F) and regulator (G) onto propane cylinder (not included). Do not cross-thread.

Turn on the propane cylinder tank.

Place the propane cylinder onto the base(H) and slide the cylinder housing (C) down.



WARNING: Use a standard 20 lb. propane cylinder only. Use this heater only with a propane vapor withdrawal supply system. See chapter 5 of the standard for storage and handling of liquefied petroleum gas, ANS/NFPA 58. Your local library or fire department should have this book.

A minimum supply pressure of 0.4 P.S.I. is required for the purpose of input adjustment for propane gas. Storage of an appliance indoors is permissible only if the cylinder is disconnected and removed from the appliance. A cylinder must be stored outdoors in a well-ventilated area out of the reach of children. A disconnected cylinder must have dust caps tightly installed and must not be stored in a building, garage or any other enclosed area. The minimum permissible gas supply pressure of 10 W.C. is required for purpose of input adjustment. A minimum of 17,000 BTUs per hour is the required input rating for a heater with a rating less than full.

The pressure regulator and hose assembly supplied with the appliance must be used.

The installation must conform with local codes, or in the absence of local codes, with national fuel gas code, ANS Z223.1/NFPA54, natural gas and propane Installation Code, CSA B149.1, or propane storage and handling code, B149.2.

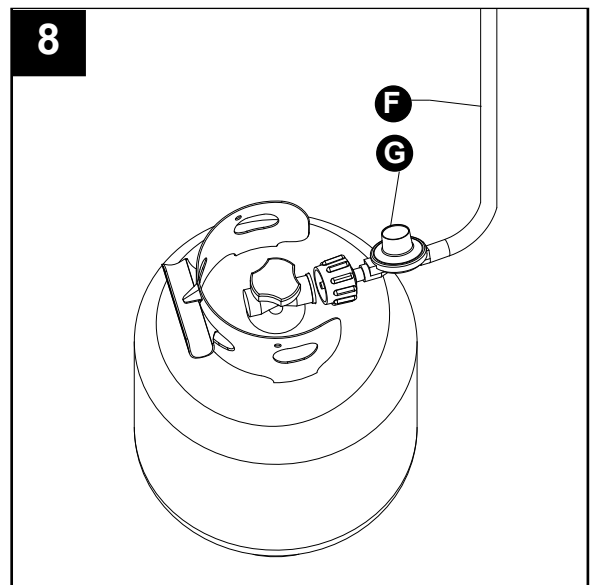
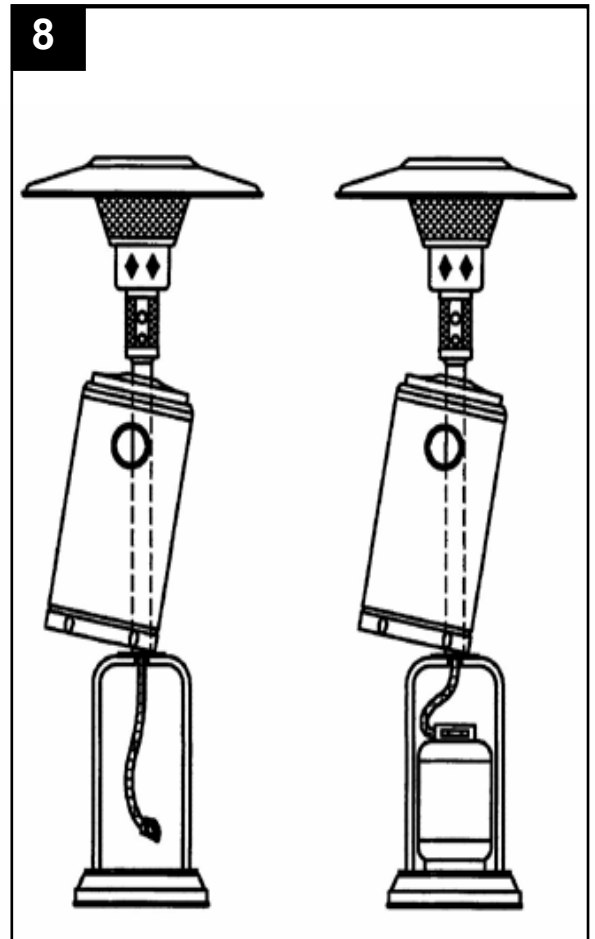

ASSEMBLY INSTRUCTIONS

A dented, rusted or damaged propane cylinder may be hazardous and should be checked by your cylinder supplier. Never use a propane cylinder with a damaged valve connection.

The propane cylinder must be constructed and marked in accordance with the specifications for LP gas cylinders of the U.S. Department of Transportation (DOT) or the standard for cylinders, spheres and tubes for transportation of dangerous goods and commission, CAN/CSA-B339.

The cylinder must have a listed overfilling prevention device.

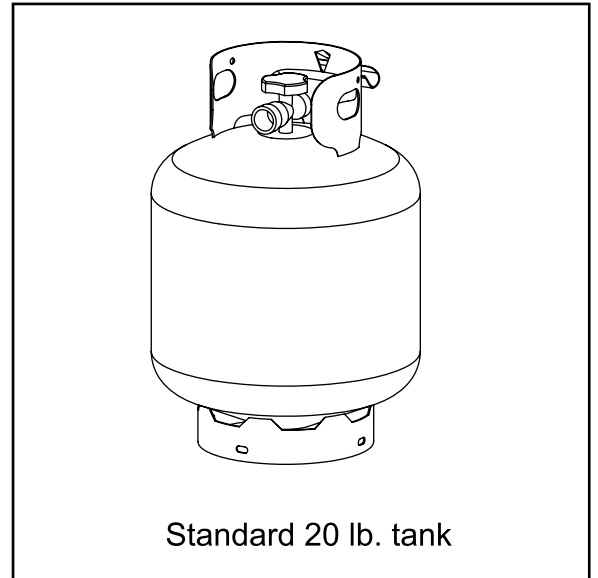

The cylinder must have a connection device compatible with the connection for the appliance.

The cylinder used must include a collar to protect the cylinder valve.

Never connect an unregulated propane cylinder to the heater.

- Do not store a spare LP-gas cylinder under or near this appliance.
- Never fill the cylinder beyond 80 percent full.
- Place the dust cap on the cylinder valve outlet whenever the cylinder is not in use. Only install the type of dust cap on the cylinder valve that is provided with the cylinder valve. Other type of caps or plugs may result in leakage of propane.

OPERATION INSTRUCTIONS

To check for a leak:

1. Make 2-3 oz. leak check solution (one part liquid dishwashing detergent and three parts water).
2. Apply several drops of solution where regulator connects to cylinder and to all hose and valve connections
3. Make sure all patio heater and light valves are OFF.
4. Turn cylinder valve ON.

If bubbles appear at any connection, there is a leak.

1. Turn cylinder valve OFF.
2. If leak is at regulator/cylinder valve connection: Disconnect, reconnect, and perform another leak check. Apply the soapy solution to all hose and valve connections. If you continue to see bubbles after several attempts, cylinder valve is defective and should be returned to cylinder's place of purchase.
3. If leak is at hose/regulator connection: This part is defective and you should contact the customer service department for replacement.

If NO bubbles appear at any connection, the connections are secure.

NOTE: Whenever gas connections are loosened or removed, you must perform a complete leak test.

WARNING

- Perform all leak tests outdoors.
- Extinguish all open flames.
- NEVER leak test when smoking.
- Do not use the heater until all connections have been leak tested and do not leak.

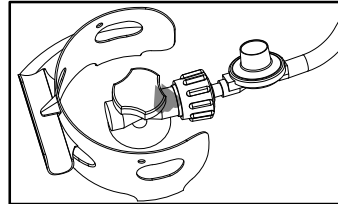

Regulator / Cylinder
connection

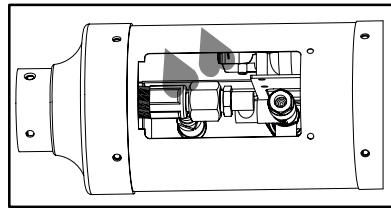

OPERATION INSTRUCTIONS

DANGER

- CARBON MONOXIDE HAZARD
- For outdoor use only. Never use inside house, or other unventilated or enclosed areas. This heater consumes air (oxygen). Do not use in unventilated or enclosed areas to avoid endangering your life.

Caution: Do not attempt to operate until you have read and understand all General Safety Information in this manual and all assembly is complete and leak checks have been performed.

Before Turning Gas Supply ON:

1. Your heater was designed and approved for outdoor use only. Do NOT use it inside a building, garage, or any other enclosed area.
2. Make sure surrounding areas are free of combustible materials, gasoline, and other flammable vapors or liquids.
3. Ensure that there is no obstruction to air ventilation. Be sure all gas connections are tight and there are no leaks.
4. Be sure the cylinder cover is clear of debris. Be sure any component removed during assembly or servicing is replaced and fastened prior to starting.

Before Lighting:

1. Heater should be thoroughly inspected before each use, and by a qualified service person at least annually. If relighting a hot heater, always wait at least 5 minutes.
2. Inspect the hose assembly for evidence of excessive abrasion, cuts, or wear. Suspected areas should be leak tested. If the hose leaks, it must be replaced prior to operation. Only use the replacement hose assembly specified by manufacturer.

CLEARANCES FROM COMBUSTIBLES:

Respect clearances as shown:

- Sides of reflector : 24 inches
- Above reflector : 18 inches

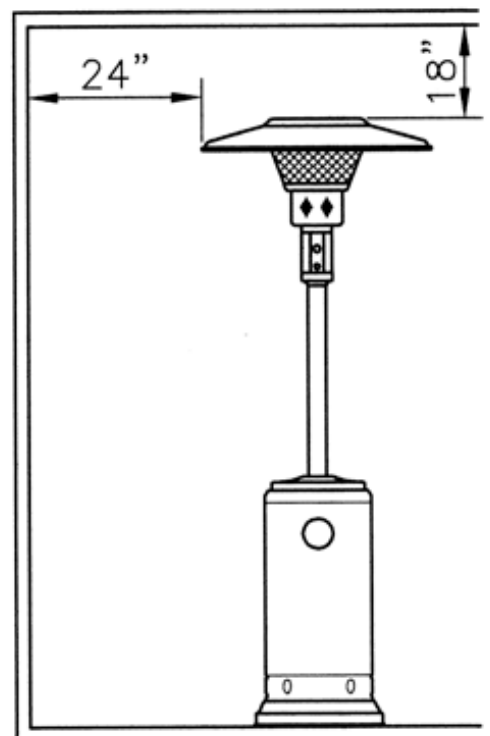

OPERATION INSTRUCTIONS

Lighting:

1. Turn on the valve on the gas cylinder.
2. Press and turn the control knob to HIGH (maximum) position (anti-clockwise 90°). (Figure 1)
3. Holding down the control knob, press the igniter button several times until the main flame is ignited. Release the control knob 10 seconds after the ignition.
4. Turn the control knob to LOW (minimum) and leave it there for 5 minutes or more before turning the knob to the desired temperature setting. (Figure 2)
5. If the burner flame goes out, turn off the heater and wait at least 5 minutes or more to let the gas dissipate before re-lighting to avoid gas explosion. Repeat steps 2 to 4.

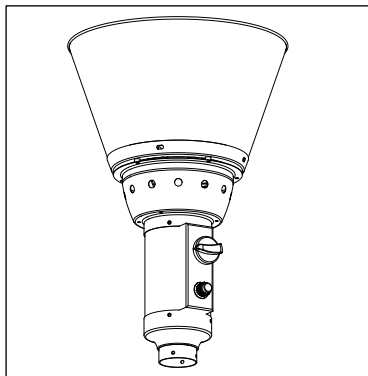

Figure 1

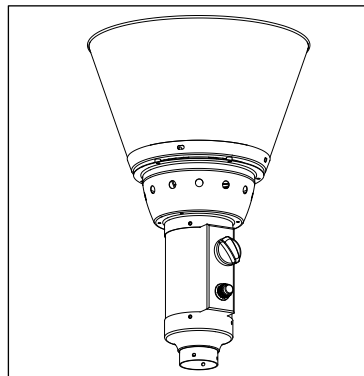
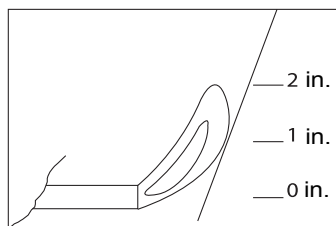

Figure 2

If you experience any ignition problem please consult “Troubleshooting” on page 17.

Caution: *Avoid inhaling fumes emitted from the heater’s first use. Smoke and odor from the burning of oils used in manufacturing will appear. Both smoke and odor will dissipate after approximately 30 minutes. The heater should NOT produce thick black smoke.*

Note: *The burner may be noisy when initially turned on. Turn the knob to the level of heat desired.*



Normal

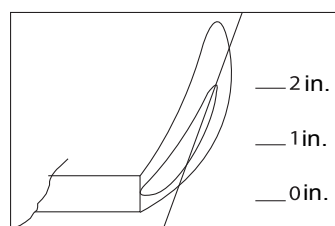

Abnormal

OPERATION INSTRUCTIONS

WARNING

FOR YOUR SAFETY

Be careful when attempting to manually ignite this heater. Holding in the control knob for more than 10 seconds before igniting the gas will cause a ball of flame upon ignition.

When Heater is ON:

Emitter screen will become bright red due to intense heat. The color is more visible at night. Burner will display tongues of blue and yellow flame. These flames should not be yellow or produce thick black smoke, indicating an obstruction of airflow through the burners. The flame should be blue with straight yellow tops. If excessive yellow flame is detected, turn off heater and consult “Troubleshooting” on page 17.

Re-lighting:

1. Turn control knob to OFF.
2. Repeat the “Lighting” steps on prior page.

WARNING

FOR YOUR SAFETY

Heater will be hot after use. Handle with extreme care.

Shut Down:

Turn cylinder valve clockwise to OFF and disconnect regulator when heater is not in use.

Note: After use, some discoloration of the emitter screen is normal.

OPERATION CHECKLIST

Perform this check before each use.

Before Operating:

- I am familiar with entire owner’s manual and understand all precautions noted.
- All components are properly assembled, intact and operable.
- No alterations have been made.
- All gas connections are secure and do not leak.
- Wind velocity is below 10 mph.
- Unit will operate at reduced efficiency below 40°F.
- Heater is outdoors (outside any enclosure).
- There is adequate fresh air ventilation.

OPERATION INSTRUCTIONS

- Heater is away from gasoline or other flammable liquids or vapors.
- Heater is away from windows, air intake openings, sprinklers and other water sources.
- Heater is at least 24 in. on top and at least 36 in. on sides from combustible materials.
- Heater is on a hard and level surface.
- There are no signs of spider or insect nests.
- All burner passages are clear.
- All air circulation passages are clear.
- Children and adults should be alerted to the hazards of high surface temperatures and should stay away to avoid burns or clothing ignition.**
- Young children should be carefully supervised when they are in the area of the fire pit. Clothing or other protective material should not be hung from the fire pit, or placed on or near the fire pit.**
- Any guard or other protective device removed for servicing the fire pit must be replaced prior to operating the fire pit.**
- Installation and repair should be done by a qualified service person. The fire pit should be inspected before use and at least annually by a qualified service person.**
- More frequent cleaning may be required as necessary. It is imperative that control compartment, burner and circulating air passageways of the fire pit be kept clean.**

After Operation

1. Gas control is in OFF position.
2. Gas tank valve is OFF.
3. Disconnect gas line.

CARE AND MAINTENANCE

WARNING

FOR YOUR SAFETY:

- Do NOT touch or move heater for at least 45 minutes after use.
- Reflector is hot to the touch.
- Allow reflector to cool before touching.

To enjoy years of outstanding performance from your heater, make sure you perform the following maintenance activities on a regular basis:

Keep exterior surfaces clean.

1. Use warm soapy water for cleaning. Never use flammable or corrosive cleaning agents.
2. While cleaning your unit, be sure to keep the area around the burner and pilot assembly dry at all times. Do not submerge the control valve assembly. If the gas control is submerged in water, do NOT use it. It must be replaced.
 - a. Keep the appliance area clear and free from combustible materials, gasoline and other flammable vapors and liquids.
 - b. Do not obstruct the flow of combustion and ventilation air.
 - c. Keep the ventilation opening(s) of the cylinder enclosure free and clear from debris.
3. Air flow must be unobstructed. Keep controls, burner, and circulating air passageways clean. Signs of possible blockage include:

CARE AND MAINTENANCE

- Gas odor with extreme yellow tipping of flame.
- Heater does NOT reach the desired temperature.
- Heater glow is excessively uneven.
- Heater makes popping noises.
- Spiders and insects can nest in burner or orifices. This dangerous condition can damage heater and render it unsafe for use. Clean burner holes by using a heavy-duty pipe cleaner. Compressed air may help clear away smaller particles.
- Carbon deposits may create a fire hazard. Clean dome and burner screen with warm soapy water if any carbon deposits develop.



Note: In a salt-air environment (such as near an ocean), corrosion occurs more quickly than normal. Frequently check for corroded areas and repair them promptly.

TIP:

Use high-quality automobile wax to help maintain the appearance of your heater. Apply to exterior surfaces from the pole down. Do not apply to emitter screen or domes.

Storage

Between uses:

- Turn Control Knob OFF.
- Disconnect LP source.
- Store heater upright in an area sheltered from direct contact with inclement weather (such as rain, sleet, hail, snow, dust and debris).
- If desired, cover heater to protect exterior surfaces and to help prevent build-up in air passages.

Note: Wait until heater is cool before covering.

During periods of extended inactivity or when transporting:

- Turn Control Knob OFF.
- Disconnect LP source and move to a secure, well-ventilated location outdoors.
- Store heater upright in an area sheltered from direct contact with inclement weather (such as rain, sleet, hail, snow, dust and debris).
- If desired, cover heater to protect exterior surfaces and to help prevent build-up in air passages. Never leave LP cylinder exposed to direct sunlight or excessive heat.

Note: Wait until heater is cool before covering.

Service

Only a qualified service person should repair gas passages and associated components.

Caution: Always allow heater to cool before attempting service.

TROUBLESHOOTING

PROBLEM	POSSIBLE CAUSE	CORRECTIVE ACTION
Burner won't light	<ol style="list-style-type: none"> 1. Propane cylinder is frosted over 2. Blockage in orifice 3. Control knob is not in ON position 	<ol style="list-style-type: none"> 1. Wait until the propane cylinder warms up and becomes unfrosted 2. Clear blockage 3. Turn control knob to ON
Burner flame is low	<ol style="list-style-type: none"> 1. Gas pressure is low 2. Outdoor temperature is less than 40°F and tank is less than 1/4 full 3. Control knob fully ON 4. Spiders and insects nest in burner or orifices 	<ol style="list-style-type: none"> 1. Turn cylinder valve OFF and replace cylinder 2. Use a full cylinder 3. Check burner and orifices for blockage 4. Clean burner and orifices
Thick black smoke	<ol style="list-style-type: none"> 1. Blockage in burner 	<ol style="list-style-type: none"> 1. Remove blockage and clean burner inside and outside
Gas odor with extreme yellow tipping of flame.	<ol style="list-style-type: none"> 1. Spiders and insects nest in burner or orifices 	<ol style="list-style-type: none"> 1. Clean burner and orifices
Heater glow is excessively uneven.	<ol style="list-style-type: none"> 1. Spiders and insects nest in burner or orifices 	<ol style="list-style-type: none"> 1. Clean burner and orifices
Heater makes popping noises.	<ol style="list-style-type: none"> 1. Spiders and insects nest in burner or orifices 	<ol style="list-style-type: none"> 1. Clean burner and orifices
Carbon build-up	<ol style="list-style-type: none"> 1. Dirt or film on reflector and burner screen 	<ol style="list-style-type: none"> 1. Clean reflector and burner screen

ONE-YEAR LIMITED WARRANTY

CUSTOMERS IN USA

For small parts please call 1-888-775-1330 for assistance. For damaged product, you may have to return to the retailer.

CUSTOMERS IN CANADA

Only return this product to the store if it was purchased within 90 days. If you have problems after 90 days of purchase, please CALL **1-888-775-1330**. DATED PROOF OF PURCHASE REQUIRED FOR WARRANTY SERVICE.

This product is inspected, tested and carefully packaged to minimize the chance of damage during shipment. If a part (excluding light bulbs and fuses*) within one year from the date of purchase proves to be defective in material or fabrication under normal use, the part will be repaired or replaced. The Company's obligation under the warranty is to replace or repair defective parts at our discretion. Any expenses or damage resulting from the installation, removal or transportation of the product will be the responsibility of the owner and are not covered by this warranty. The owner assumes all other risks arising out from the use or misuse of the product. The warranty will be void if the product damage or failure is deemed by the Company to be caused by accident, alteration, misuse, abuse, incorrect installation or removal, or connection to an incorrect power source by the owner. The Company neither assumes, nor authorizes any person or entity to assume for it any obligation or liability associated with its products.

* Light bulbs and fuses are not covered under this warranty.

If you have any questions regarding the warranty or service, please call our toll free number: **1-888-775-1330**.

Distributed by:

AZ Patio Heaters, LLC

Toll Free Number **1-888-775-1330**

Sales Service and Repair

www.azpatioheaters.com

REPLACEMENT PARTS LIST

For replacement parts, call our customer service department at **1-888-775-1330**,
8 a.m. - 4 p.m., MST, Monday - Friday.

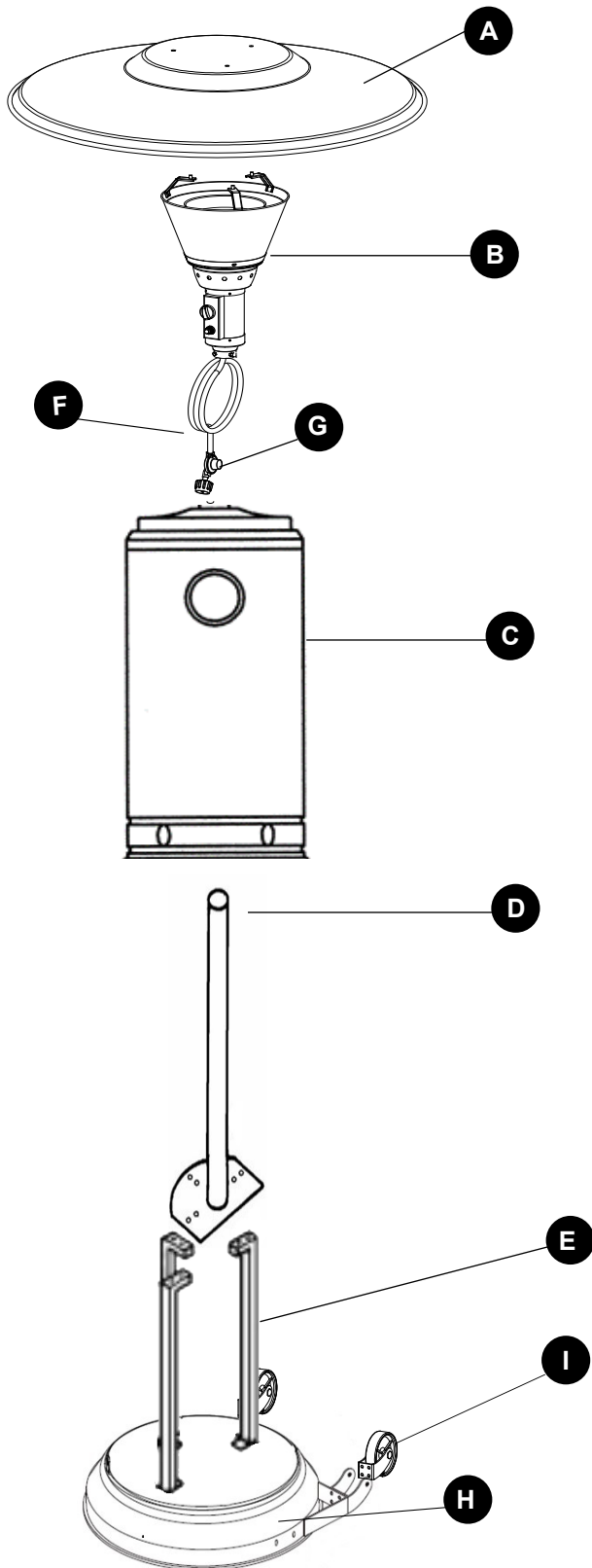

PART	DESCRIPTION	QUANTITY
A	Reflector Panel	1
B	Burner Head Assembly	1
C	Cylinder Housing	1
D	Post	1
E	Support Brackets	3
F	Gas Hose	1
G	Regulator	1
H	Base with Weighted Plate	1
I	Wheel Kit	2

Printed in Taiwan