

AXOR

EN /Installation / User Instructions / Warranty
FR /Instructions de montage / Mode d'emploi / Garantie
ES /Instrucciones de montaje / Manejo / Garantía

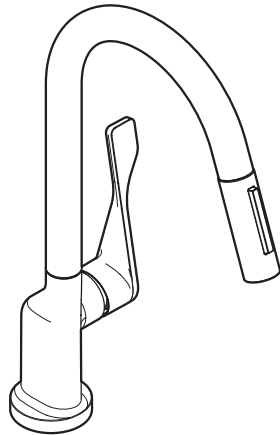

AXOR Citterio
39835xx1
39836xx1

INSTALLATION

ENGLISH

TECHNICAL INFORMATION

Water pressure	
Recommended	15 - 75 PSI (0.1 - 0.5 MPa)
Maximum	145 PSI (1 MPa)
Hot water temp.	
Recommended	120°-140° F (48° - 60° C)*
Maximum	158°F (70° C)*
Max. flow rate	1.75 GPM (6.6 L/min)
Hole size in mounting surface	1 1/2" (38 mm)
Max. depth of mounting surface	2 3/4" (70 mm)

* Please know and follow all applicable local plumbing codes when setting the temperature on the water heater.

INSTALLATION CONSIDERATIONS

- / For best results, Hansgrohe recommends that this unit be installed by a licensed, professional plumber.
- / Please read over these instructions thoroughly before beginning installation. Make sure that you have all tools and supplies needed to complete the installation.
- / Protection against backflow is provided by two check valves in the sprayhead.
- / Keep this booklet and the receipt (or other proof of date and place of purchase) for this product in a safe place. The receipt is required should it be necessary to request warranty parts.

FRANÇAIS

DONNÉES TECHNIQUES

Pression d'eau	
recommandée	15 - 75 PSI (0.1 - 0.5 MPa)
maximum	145 PSI (1 MPa)
Température d'eau chaude	
recommandée	120°-140° F (48° - 60° C)*
maximum	158°F (70° C)*
Capacité nominale	1.75 GPM (6.6 L/min)
Dimension du trou dans la surface de montage	1 1/2 po (38 mm)
Profondeur maximale de la surface de montage	2 3/4 po (70 mm)

* Vous devez connaître et respecter tous les codes de plomberie locaux applicables pour le réglage de la température du chauffe-eau.

À PRENDRE EN CONSIDÉRATION POUR L'INSTALLATION

- / Pour de meilleurs résultats, Hansgrohe recommande que ce produit soit installé par un plombier professionnel licencié.
- / Veuillez lire attentivement ces instructions avant de procéder à l'installation. Assurez-vous de disposer de tous les outils et du matériel nécessaires pour l'installation.
- / La protection contre le retour d'eau est fournie par un clapet de non-retour double.
- / Conservez ce livret et le reçu (ou une autre preuve sur laquelle figurent la date et l'endroit de l'achat) pour ce produit dans un endroit sûr. Le reçu est requis si vous commandez des pièces sous garantie.

ESPAÑOL

DATOS TECNICOS

Presión en servicio	
recomendada	15 - 75 PSI (0.1 - 0.5 MPa)
max.	145 PSI (1 MPa)
Temperatura del agua caliente	
recomendada	120°-140° F (48° - 60° C)*
max.	158°F (70° C)*
Caudal máximo	1.75 GPM (6.6 L/min)
Tamaño del orificio en la superficie de montaje	1 1/2" (38 mm)
Profundidad máxima de la superficie de montaje	2 3/4" (70 mm)

* Debe conocer y cumplir todos los códigos locales aplicables para ajustar la temperatura del calentador de agua.

CONSIDERACIONES PARA LA INSTALACIÓN

- / Para obtener mejores resultados, la instalación debe estar a cargo de un plomero profesional matriculado.
- / Antes de comenzar la instalación, lea estas instrucciones detenidamente. Asegúrese de tener las herramientas y los insumos necesarios para completar la instalación.
- / La protección contra flujo inverso se proporciona mediante una válvula de retención doble.
- / Mantenga este folleto y el recibo (u otro comprobante del lugar y fecha de compra) de este producto en lugar seguro. El recibo se requiere en caso de ser necesario solicitar piezas bajo garantía.

TOOLS REQUIRED / OUTILES UTILES / HERRAMIENTAS ÚTILES

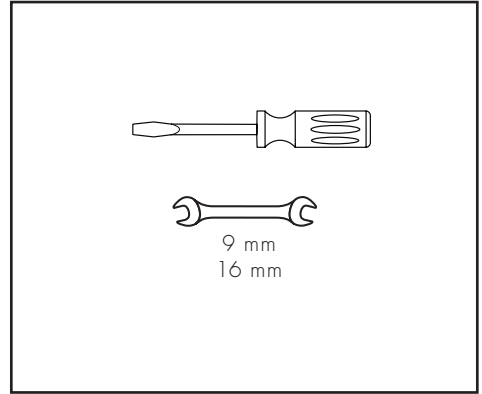

AXOR Citterio
39835xx1

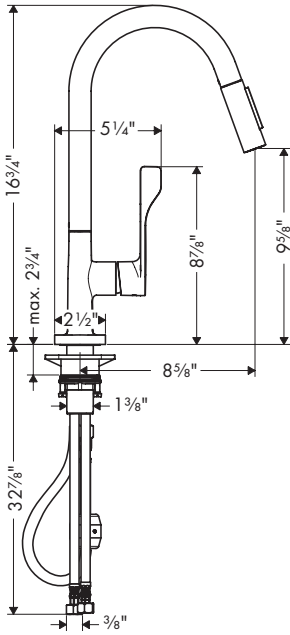

AXOR Citterio
39836xx1

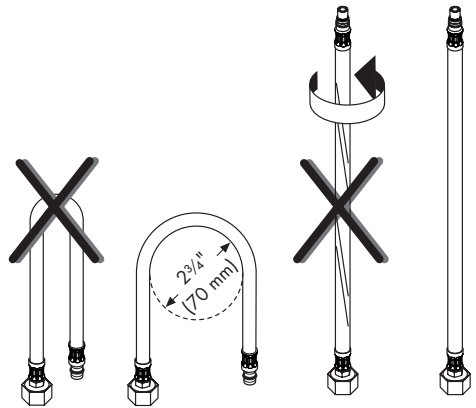
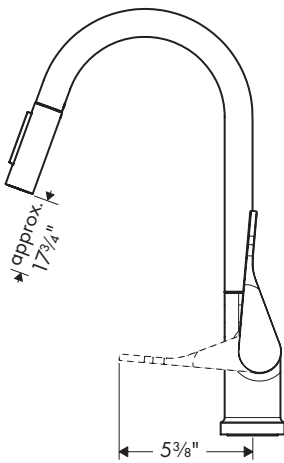
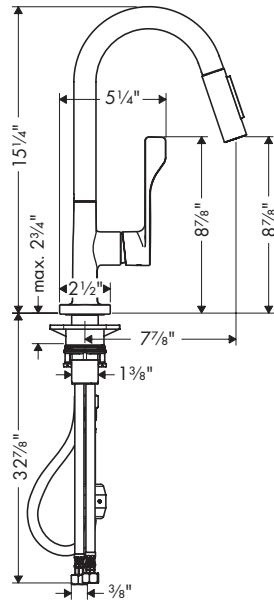

OPTIONAL: ADJUST THE SPOUT ROTATION / AJUSTEZ LA ROTACION
DU BEC / AJUSTE LA ROTACIÓN DEL SURTIDOR

39835XX1

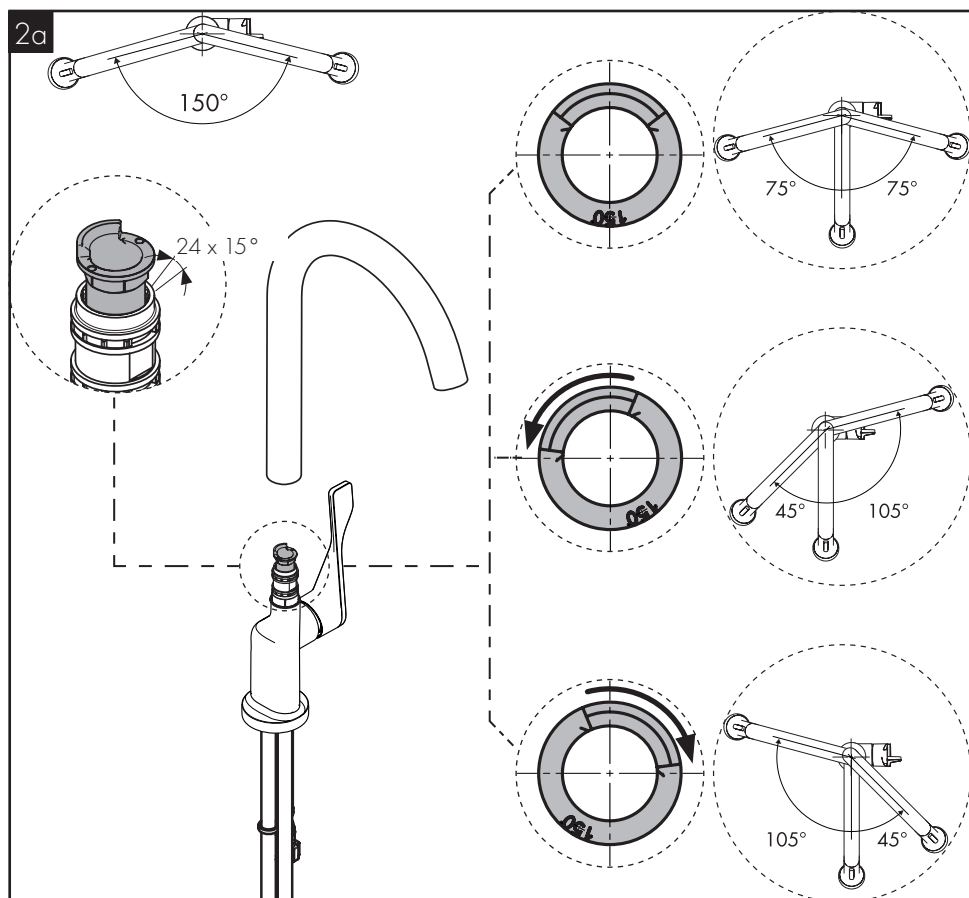
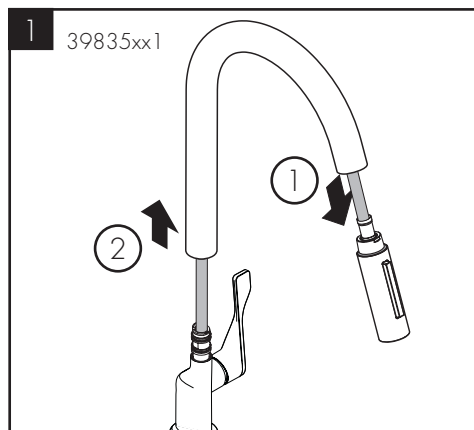

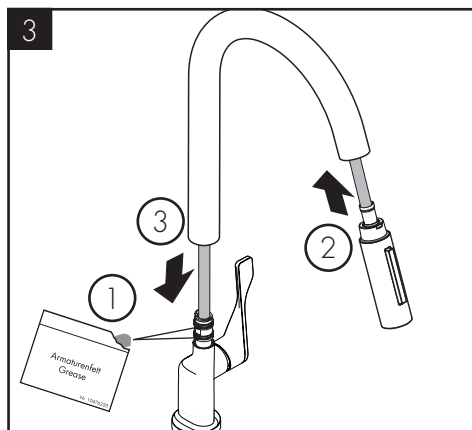
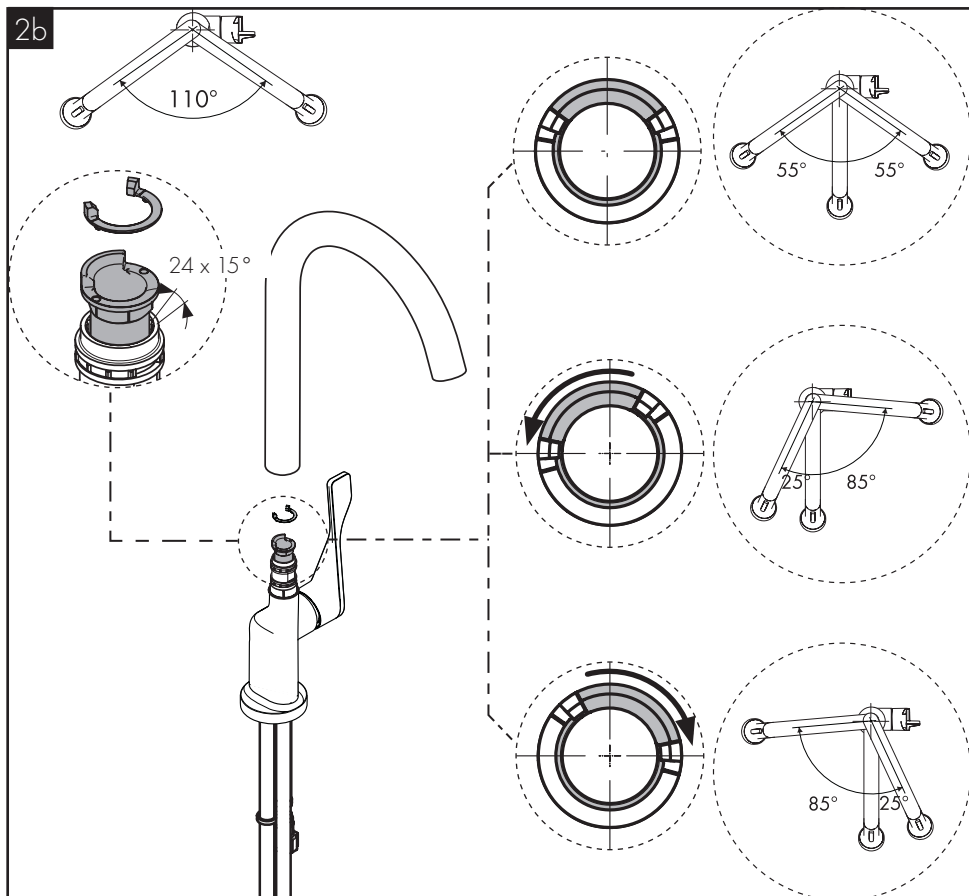

INSTALLATION / INSTALLATION / INSTALACIÓN

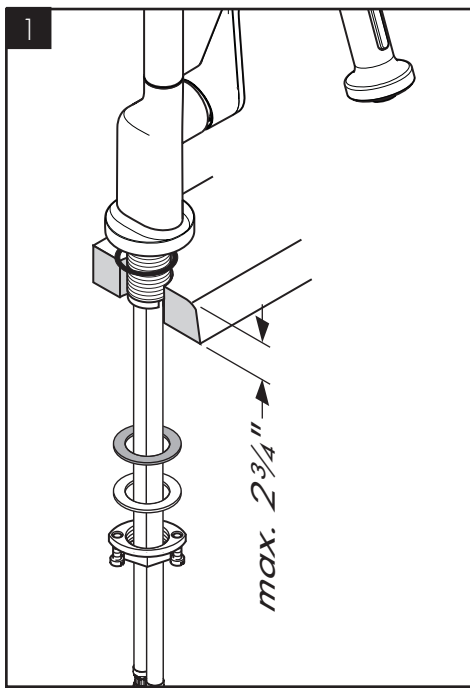

ENGLISH

Place the faucet and sealing ring on the mounting surface.

Install the friction washer, metal washer, and mounting nut.

Tighten the mounting nut.

Tighten the screws.

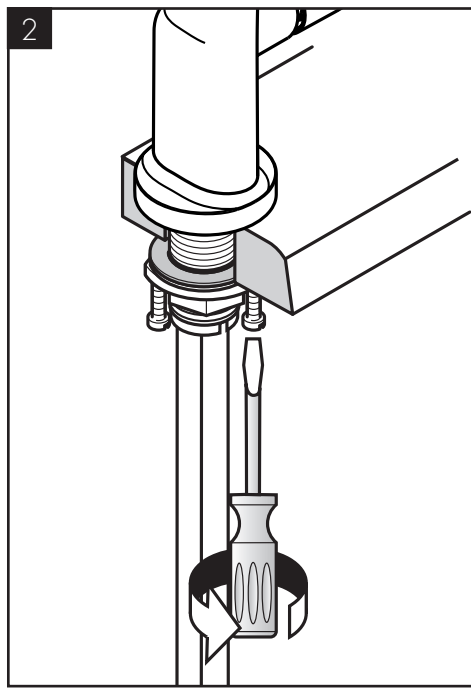

FRANÇAIS

Placez l'anneau d'étanchéité et le robinet sur la surface de montage.

Installez la rondelle en fibre, la rondelle de friction, et l'écrou de montage.

Serrez l'écrou de montage et les vis de serrage.

ESPAÑOL

Coloque el oro de sellado y el grifo sobre la superficie de montaje.

Instale la arandela de fibra, la arandela de fricción y la tuerca de fijación.

Apretete la tuerca de fijación y los tornillos.

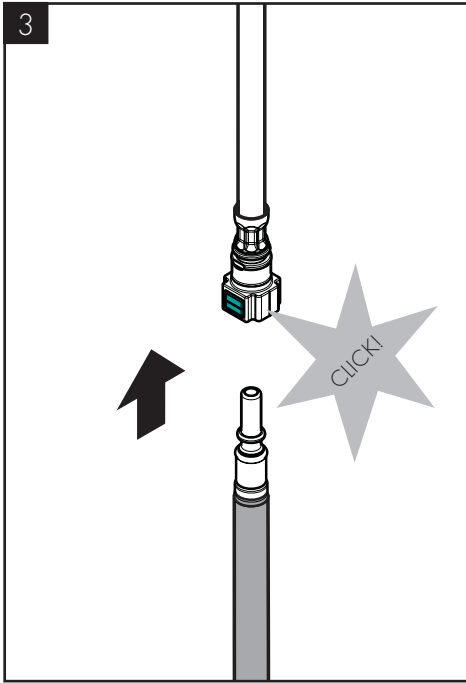

ENGLISH

Connect the handspray hose to the connection hose.

Install the hose weight.

Test the handspray hose. If it does not retract smoothly, reposition the weight.

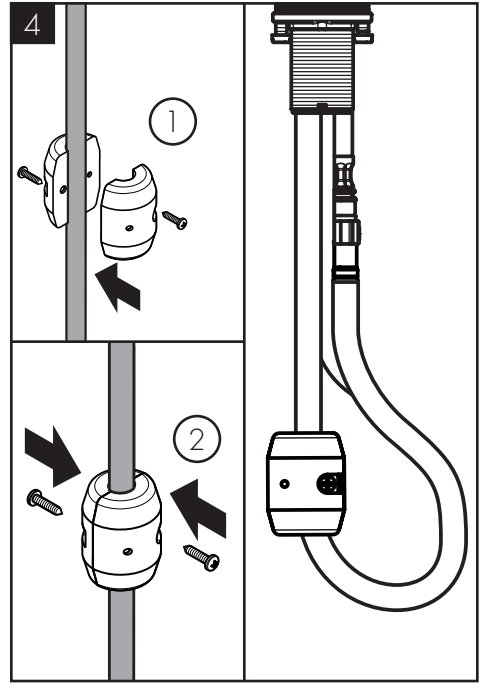

FRANÇAIS

Raccordez le tuyau de la douchette au tuyau d'arrivée de la douchette.

Installez le contrepoids sur le tuyau.

Tirez sur la douchette. Elle devrait coulisser facilement et se rétracter sans à-coups. Modifiez la position du contrepoids au besoin.

ESPAÑOL

Conecte la manguera de rociador de mano a la manguera de suministro.

Instale el contrapeso.

Tire del rociador de mano. Debe moverse con facilidad y retraerse suavemente. Reposicione el contrapeso según sea necesario.

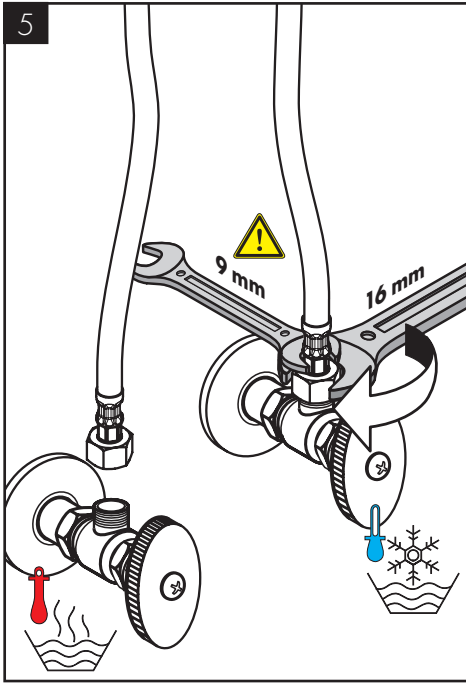

ENGLISH

Connect the hot and cold supply hoses to the stops.

Use two wrenches. Do not allow the supply hoses to twist.

Remove the sprayhead.

Remove the filter.

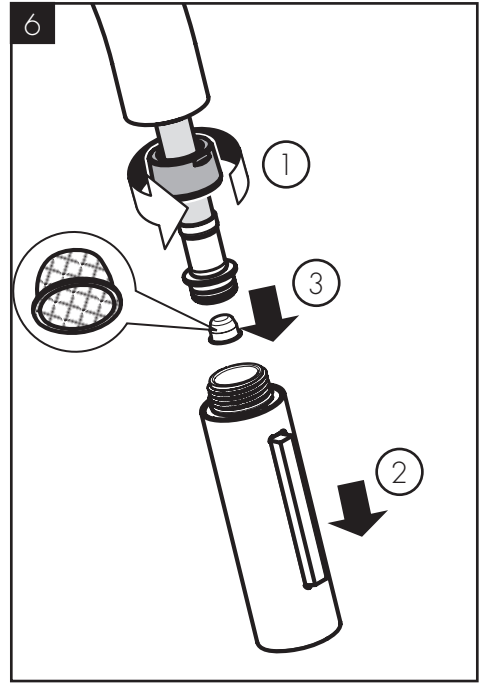

FRANÇAIS

Connectez les tuyaux d'arrivée d'eau chaude et d'eau froide aux tuyau d'alimentation.

Serrez fermement à l'aide de deux clés. Assurez-vous que les tuyaux n'sentortillent pas.

Retirez le douchette.

Retirez le filtre.

ESPAÑOL

Conecte las mangueras de suministro de agua caliente y fría a las alimentaciones de la red.

Use dos llaves, como se ilustra en el diagrama. No permita que ninguna de los mangueras se retuerza.

Retire la ducha.

Retire el filtro.

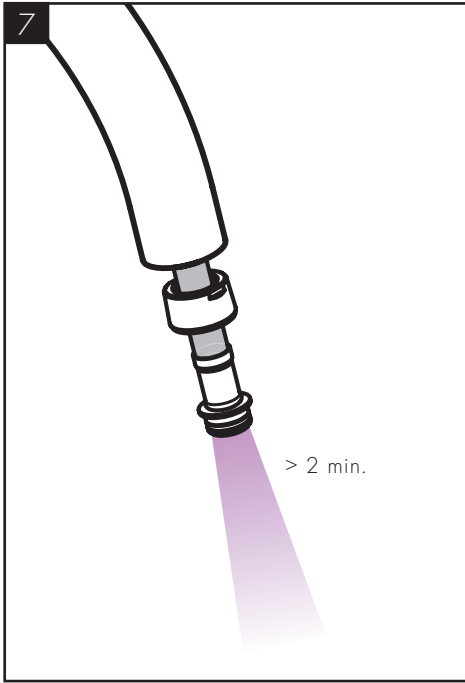

ENGLISH

Flush the hot and cold supplies for at least two minutes.

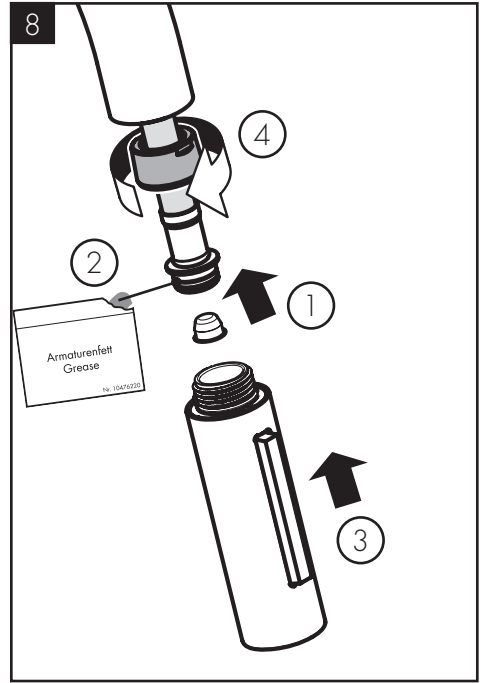

FRANÇAIS

Rincez les conduites d'alimentation de l'eau chaude et de l'eau froide.

ESPAÑOL

Lave los suministros de agua caliente y fría.

Install the filter in the handspray hose.

Lightly lubricate the hose o-ring.

Install the handspray. Tighten the hose nut.

Installez le filtre dans le tuyau flexible.

Lubrifiez le joint torique du tuyau.

Installez le douchette. Serrez l'écrou.

Instale el filtro en la manguera.

Lubrique ligeramente la junta tórica de la manguera.

Instale la ducha.

Apriete la tuerca de la manguera.

SET THE HIGH TEMPERATURE LIMIT STOP / RÉGLAGE DE LA BUTÉE
 LIMITE D'EAU CHAUDE / AJUSTE EL TOPE DE LÍMITE DE ALTA
 TEMPERATURA

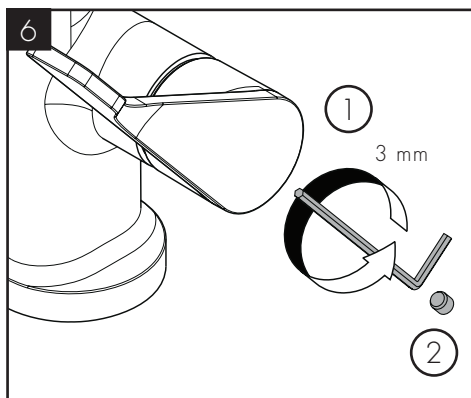
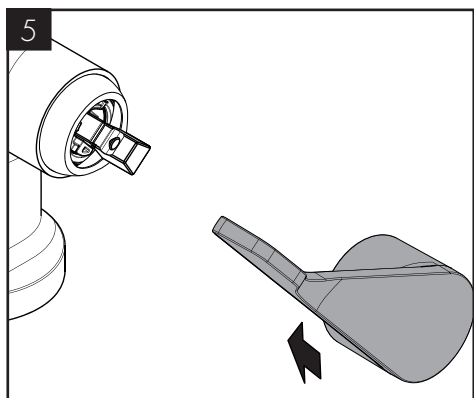
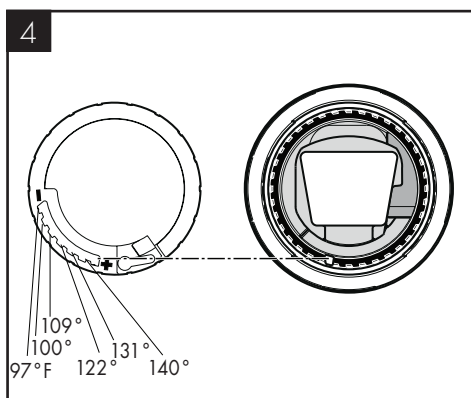
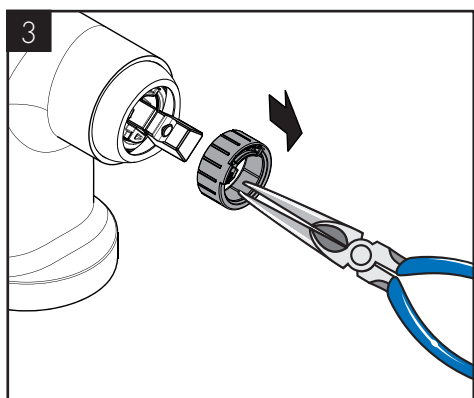
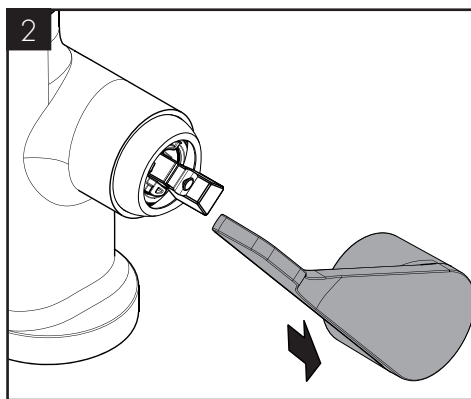
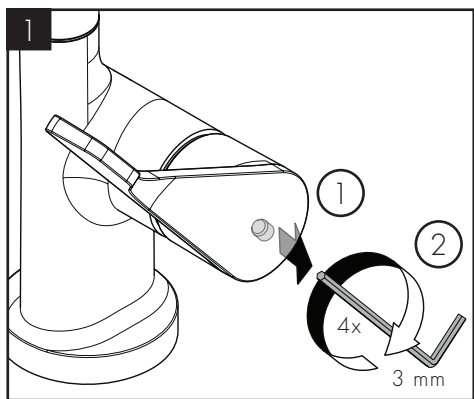

REPLACEMENT PARTS / PIÈCES DÉTACHÉES / REPUESTOS

AXOR Citterio
39835xx1

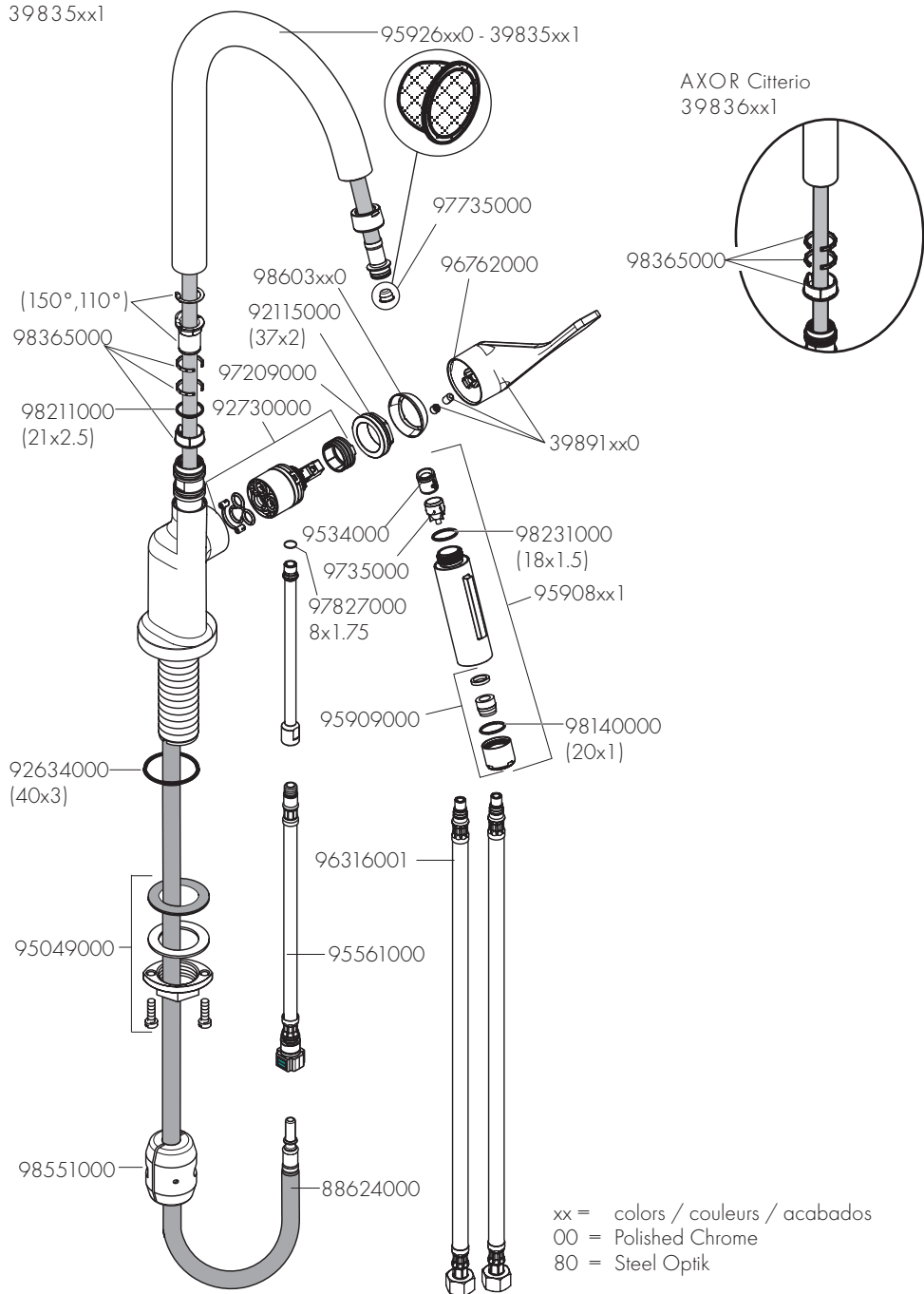

USER INSTRUCTIONS / INSTRUCTIONS DE SERVICE / MANEJO

off
fermé
cerrar

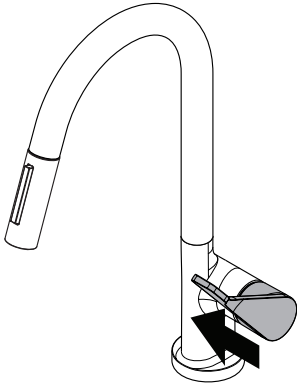

on
ouvert
abierto

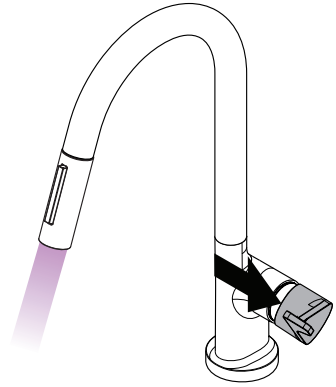

hot
chaud
caliente

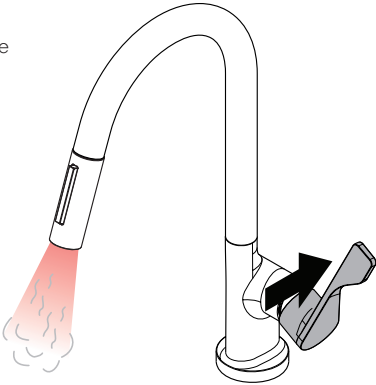

cold
froid
frio

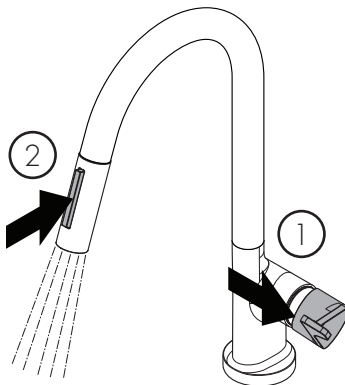
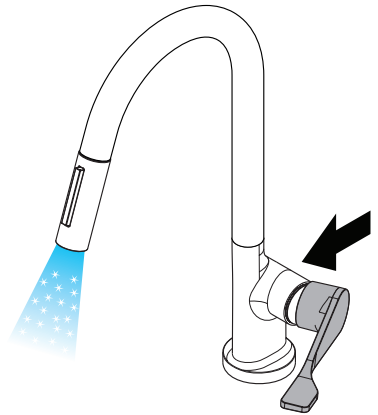

CLEANING / NETTOYAGE / LIMPIEZA

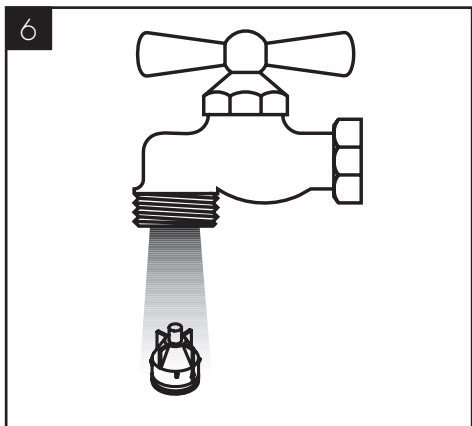
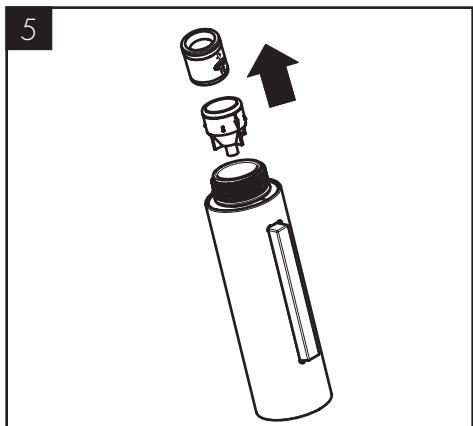
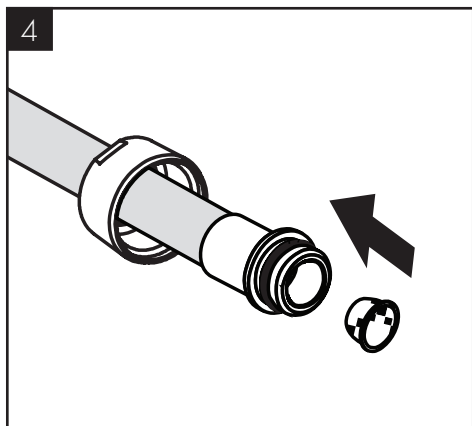
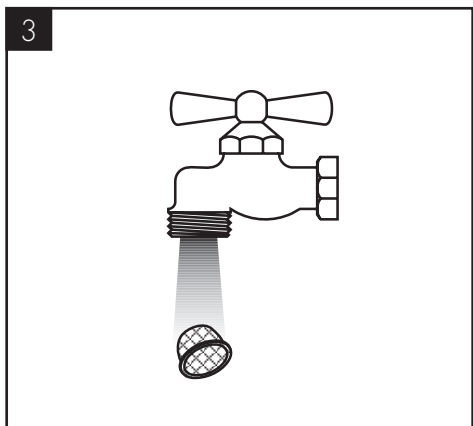
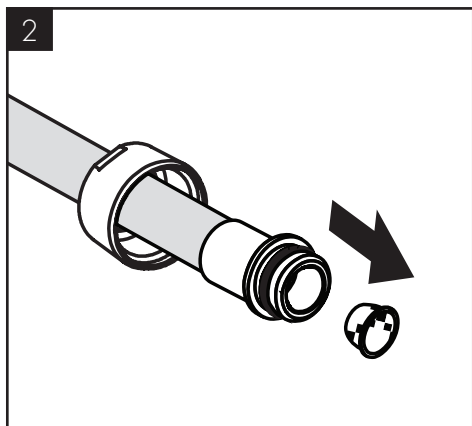
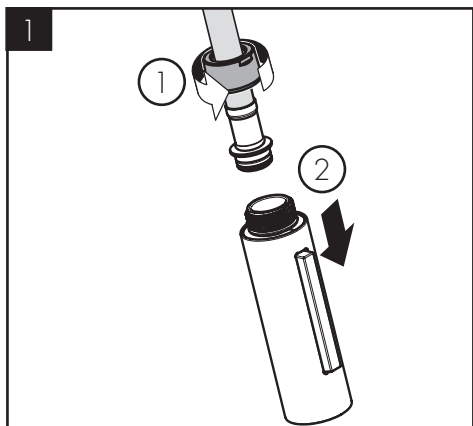

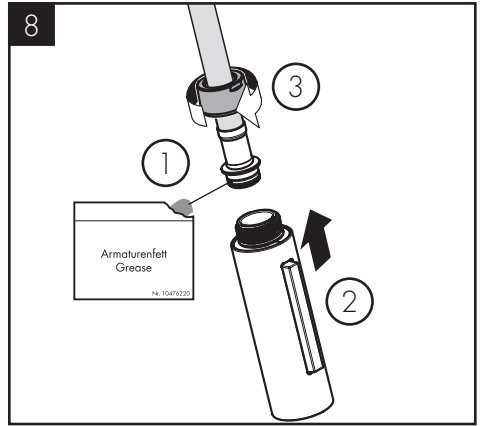
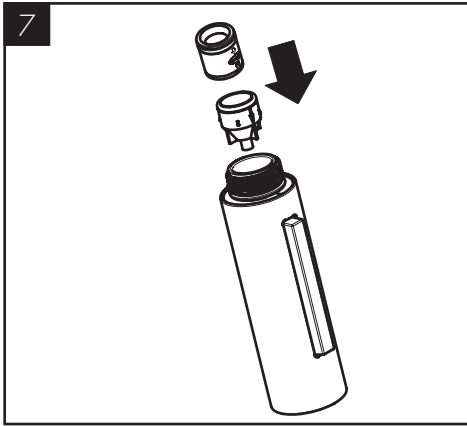

CLEANING RECOMMENDATION FOR HANSGROHE PRODUCTS

Modern bathroom faucets, kitchen faucets and shower products are made from different materials to comply with the needs of the market with regard to design and functionality. To avoid damage to the product, it is necessary to take proper care of it.

FOR BEST RESULTS:

- / Prevent the buildup of mineral scale and /or soap residue by cleaning your Hansgrohe product(s) when needed.
- / Select a cleaning agent specifically intended for the type of product.
- / DO NOT use these types of cleaners as they will cause damage to your Hansgrohe product:
 - Any cleaning agent containing hydrochloric acid, formic acid, lye, or acetic acid.
 - Abrasive cleaning powders, pads, or brushes.
 - Steam cleaners.
 - "No rinse" cleaning agents.
- / ALWAYS follow the instructions provided by the manufacturer of the cleaning agent.
- / DO NOT mix cleaning agents, unless directed by the manufacturer.
- / DO NOT spray cleaners directly onto the product as drops could enter openings and gaps and cause damage. When using spray cleaners, spray the cleaner onto a soft cloth or sponge.
- / ALWAYS rinse your Hansgrohe product thoroughly with clear water and polish dry with a soft cloth after cleaning.

IMPORTANT

- / Residue from soaps and shampoos can cause damage. Rinse the product with clean water after each use.
- / Residue from basin/tub/tile cleaner can cause damage to faucets and fittings. Immediately rinse any overspray from the Hansgrohe product.
- / Do not store any cleaning agents under your Hansgrohe product, such as in a vanity unit, as the fumes may damage the product.
- / DAMAGE TO THE PRODUCT CAUSED BY IMPROPER CARE OR THE USE OF IMPROPER CLEANING AGENTS IS NOT COVERED BY THE WARRANTY.
- / IF A COMPONENT OF THE PRODUCT IS DAMAGED, REINSTALL IT, AS THERE IS RISK OF INJURY.

CONSEIL DE NETTOYAGE POUR LES PRODUITS HANSGROHE

Les robinets pour les salles de bains et les cuisines modernes ainsi que les produits récents pour les douches se composent de matériaux différents afin de satisfaire aux besoins du marché en termes de conception et de fonctionnalité. Afin d'éviter d'endommager le produit, il est nécessaire d'en prendre soin.

POUR DE MEILLEURS RÉSULTATS :

- / Empêchez l'accumulation de tarte et/ou de résidu de savon en nettoyant votre produit Hansgrohe lorsque c'est nécessaire.
- / Sélectionnez un produit de nettoyage spécifiquement prévu pour ce type de produit.
- / N'UTILISEZ PAS ces types de nettoyeurs car ils peuvent endommager votre produit Hansgrohe :
 - Tout produit de nettoyage contenant de l'acide chlorhydrique, de l'acide formique, de la potasse ou de l'acide acétique.
 - Les poudres de nettoyage, les tampons ou les brosses abrasives.
 - Les nettoyeurs à vapeur.
 - Les produits de nettoyage « sans rinçage ».
- / NE MÉLANGEZ PAS les produits de nettoyage, à moins que cela soit indiqué par le fabricant.
- / NE PULVÉRISEZ PAS les nettoyeurs directement sur le produit car des gouttes pourraient entrer dans les ouvertures et les fentes et causer des dommages. Lorsque vous utilisez des nettoyeurs par pulvérisation, pulvérisez le nettoyant sur un chiffon ou une éponge douce.
- / Après le nettoyage rincer abondamment à l'eau claire pour éliminer intégralement les restes de détergent.

IMPORTANT

- / Les residus de produits pour le corps comme les savons liquides, shampooings, gels de douche, teintures pour cheveux, parfums, apres-rasage et vernis a ongles peuvent causer des deteriorations. Rincez le produit avec de l'eau propre après chaque utilisation.
- / Le résidu provenant des nettoyeurs pour cuvette/baignoire/carrelage peut endommager les robinets et les raccords de tuyauterie. Rincez immédiatement toute surpulvérisation sur le produit Hansgrohe.
- / De meme, il est interdit de stocker des detergents ou des produits chimiques sous les produits, par ex. dans un meuble sous lavabo, car les vapeurs qui s'en degagent risquent d'abimer les produits.
- / LES DOMMAGES AU PRODUIT CAUSÉS PAR UN MAUVAIS ENTRETIEN OU PAR L'UTILISATION DE PRODUITS DE NETTOYAGE INADÉQUATS NE SONT PAS COUVERTS PAR LA GARANTIE.
- / SI UN COMPOSANT DU PRODUIT EST ENDOMMAGÉ, REMPLACEZ-LE, CAR IL EXISTE UN RISQUE DE BLESSURE.

RECOMENDACIÓN DE LIMPIEZA PARA LOS PRODUCTOS DE HANSGROHE

Hoy en día, las griferías de baño y de cocina así como duchas modernas se componen de materiales muy distintos para satisfacer las exigencias del mercado respecto al diseño y la funcionalidad. Para evitar daños y reclamaciones hay que tener en cuenta ciertos aspectos tanto en el uso como en su limpieza.

PARA OBTENER MEJORES RESULTADOS:

- / Evite la acumulación de restos de jabón o sarro limpiando el producto Hansgrohe cuando sea necesario.
- / Seleccione un agente de limpieza diseñado específicamente para el tipo de producto.
- / NO USE estos tipos de limpiadores, ya que causarán daño a su producto Hansgrohe:
 - Agentes limpiadores que contengan ácido clorhídrico, fórmico, acético o lejía.
 - Polvos, paños o cepillos de limpieza abrasivos.
 - Limpiadores a vapor
 - Agentes de limpieza "sin enjuague".
- / SIEMPRE siga las instrucciones provistas por el fabricante del agente de limpieza.
- / NO MEZCLE los agentes de limpieza, a menos que esté indicado por el fabricante.
- / No rocíe limpiadores directamente sobre el producto, ya que podrían caer gotas sobre las aberturas y espacios y causar daños. Cuando use limpiadores en spray, rocíe el limpiador sobre un paño suave o esponja.
- / SIEMPRE enjuague su producto Hansgrohe con agua limpia y séquelo y lústrelo con un paño suave después de la limpieza.

IMPORTANTE

- / Los residuos de productos de aseo como jabon liquido, champus, gel de ducha, tintes de pelo, perfumes, lociones de afeitado y esmalte de unas pueden danar tambien los materiales. Enjuague el producto con agua limpia después de cada uso.
- / Los residuos de limpiadores para lavatorios, bañeras o azulejos pueden causar daño a los grifos y accesorios. Enjuague inmediatamente cualquier derrame que haya sobre el producto de Hansgrohe.
- / Tampoco pueden generarse depositos de productos de limpieza o quimicos debajo de los productos, p. ej. en un armario de lavabo. De lo contrario, los vapores generados pueden danar los productos.
- / LOS DAÑOS QUE RESULTEN DE UN CUIDADO INADECUADO O USO DE AGENTES DE LIMPIEZA INADECUADOS NO ESTÁN CUBIERTOS POR LA GARANTÍA.
- / SI SE DAÑA UN COMPONENTE DEL PRODUCTO, REEMPLÁCELO, YA QUE EXISTE RIESGO DE LESIÓN.

LIMITED CONSUMER WARRANTY

This warranty is limited to products manufactured by Hansgrohe, Inc. that are purchased by a consumer in the United States or Canada after March 1, 1996, and installed in either the United States or in Canada.

WHO IS COVERED BY THE WARRANTY

This limited warranty extends to the original purchaser only. This warranty is non-transferable. Hansgrohe, Inc. neither assumes nor authorizes any person to create for it any other obligation or liability in connection with this product.

LENGTH OF WARRANTY

If you are a consumer who purchased the product for use primarily for personal, family or household purposes, this limited warranty starts on the date of purchase and extends for as long as you own the product and the home in which the product is originally installed. If you purchased the product for use primarily for any other purpose, including, without limitation, a commercial purpose, this limited warranty starts on the date of purchase and extends (i) for 1 year, with respect to hansgrohe brand products and commercial products, and (ii) for 5 years, with respect to AXOR products. The Rubbed Bronze finish is subject to a 3-year limited warranty starting on the date of purchase.

WHAT IS COVERED BY THE WARRANTY

This limited warranty covers only your manufactured product. Hansgrohe, Inc. warrants this product against defects in material or workmanship as follows:

Hansgrohe, Inc. will replace at no charge for parts only or, at its option, replace any product or part of the product that proves defective because of improper workmanship and/or material, under normal installation, use, service and maintenance. If Hansgrohe, Inc. is unable to provide a replacement and repair is not practical or cannot be made in timely fashion, Hansgrohe, Inc. may elect to refund the purchase price in exchange for the return of the product. REPAIR OR REPLACEMENT (OR, IN LIMITED CIRCUMSTANCES, REFUND OF THE PURCHASE PRICE) AS PROVIDED UNDER THIS LIMITED WARRANTY IS THE EXCLUSIVE REMEDY OF THE PURCHASER.

WHAT IS NOT COVERED BY THE WARRANTY

- A. Conditions, malfunctions or damage not resulting from defects in material or workmanship.
- B. Conditions, malfunctions or damage resulting from (1) normal wear and tear, improper installation, improper maintenance, misuse, abuse, negligence, accident or alteration; (2) the use of abrasive or caustic cleaning agents or "no-rinse" cleaning products, or the use of the product in any manner contrary to the product instructions; or (3) conditions in the home such as excessive water pressure or corrosion.

- C. Labor and other expenses for disconnection, deinstallation, or return of the product for warranty service (including but not limited to proper packaging and shipping costs), or for installation or reinstallation of the product.
- D. Accessories, connected materials and products, or related products not manufactured by Hansgrohe, Inc.
- E. Any hansgrohe or AXOR product sold for display purposes.
- F. Custom products are non-returnable and cannot be cancelled upon receipt of order confirmation sent from Hansgrohe, Inc.

HANSGRÖHE, INC. SHALL NOT BE LIABLE TO PURCHASER OR ANY OTHER PERSON FOR ANY INCIDENTAL, SPECIAL OR CONSEQUENTIAL DAMAGES, ARISING OUT OF BREACH OF THIS LIMITED WARRANTY.

Some provinces and some states do not allow the exclusion or limitation of incidental or consequential damages, so the above limitation or exclusion may not apply to you.

TO OBTAIN WARRANTY PARTS OR INFORMATION

Contact your Hansgrohe retailer, or contact Technical Service at:

Hansgrohe, Inc.
1492 Bluegrass Lakes Parkway
Alpharetta, GA 30004
Toll-free 800-334-0455

In requesting warranty service, you will need to provide:

1. The sales receipt or other evidence of the date and place of purchase.
2. A description of the problem.
3. Delivery of the product or the defective part, postage prepaid and carefully packed and insured, to:

Hansgrohe, Inc.
1492 Bluegrass Lakes Parkway
Alpharetta, GA 30004
Toll-free 800-334-0455

When warranty service is completed, any repaired or replacement product or part will be returned to you postage prepaid. REVISED MAY 1, 2016.

PRODUCT INSTRUCTIONS AND QUESTIONS

Upon purchase or prior to installation, please carefully inspect your product for any damage or visible defect. Prior to installing, always carefully study the enclosed instructions on the proper installation and the care and maintenance of this product. If you have questions at any time about the use, installation or performance of your product, or the Limited Warranty, please write us or call us toll-free at 800-334-0455.

AXOR

AXOR / Hansgrohe, Inc.
1490 Bluegrass Lakes Parkway
Alpharetta, GA 30004

Tel. 800-334-0455
Fax 770-889-1783

axor-design.com