

AXOR[®]

hansgrohe

- EN** Installation / User Instructions / Warranty
FR Instructions de montage / Mode d'emploi / Garantie
ES Instrucciones de montaje / Manejo / Garantía

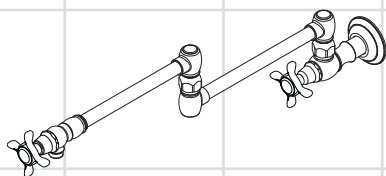

Montreux
16859xx0

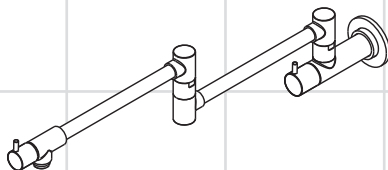

Starck
10859xx0

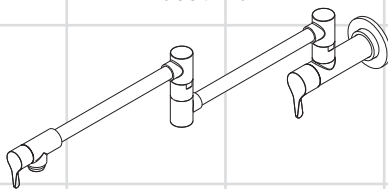

Citerio
39834xx0

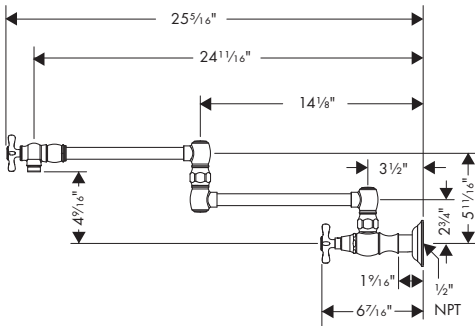

16859xx0

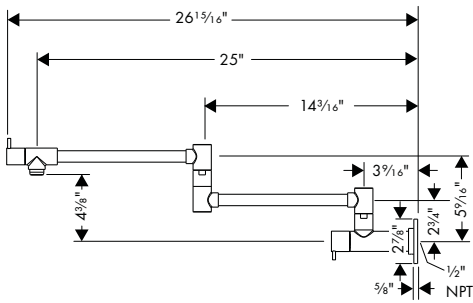

10859xx0

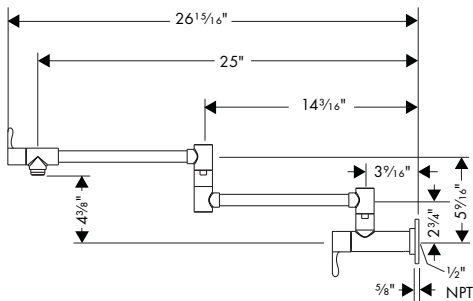

39834xx0

Technical Information

Recommended water pressure	15 - 75 PSI
Max. water pressure	145 PSI
Flow rate	2.2 GPM
Hole size in mounting surface	1 3/16"
Max. depth of mounting surface	1 1/2"

Installation Considerations

- For best results, Hansgrohe recommends that this unit be installed by a licensed, professional plumber.
- Please read over these instructions thoroughly before beginning installation. Make sure that you have all tools and supplies needed to complete the installation.



This faucet is for use with cold water only. Do not connect it to the hot water supply.

- This faucet requires a 1/2" male nipple, extending 1/2" outside the surface of the finished wall.
- The wall must be reinforced at the mounting point.
- Keep this booklet and the receipt (or other proof of date and place of purchase) for this product in a safe place. The receipt is required should it be necessary to request warranty parts.

Données techniques

Pression d'eau recommandée	15 - 75 PSI
Pression d'eau maximum	145 PSI
Capacité nominale	2.2 GPM
Dimension du trou dans la surface de montage	1 3/16 po
Profondeur maximale de la surface de montage	1 1/2 po

Datos tecnicos

Presión recomendada en servicio	15 - 75 PSI
Presión en servicio max.	145 PSI
Caudal máximo	1.5 GPM
Tamaño del orificio en la superficie de montaje	1 3/16"
Profundidad máxima de la superficie de montaje	1 1/2"

À prendre en considération pour l'installation

- Pour de meilleurs résultats, Hansgrohe recommande que ce produit soit installé par un plombier professionnel licencié.
- Veuillez lire attentivement ces instructions avant de procéder à l'installation. Assurez-vous de disposer de tous les outils et du matériel nécessaires pour l'installation.
- Ce robinet requiert un raccord mâle fileté NPT de 1/2 po dont une partie de 1/2 po doit dépasser de la surface du mur fini.
- Installez les supports de montant pour la bride de fixation.

! Ce robinet est conçu uniquement pour l'eau froide.

- Conservez ce livret et le reçu (ou une autre preuve sur laquelle figurent la date et l'endroit de l'achat) pour ce produit dans un endroit sûr. Le reçu est requis si vous commandez des pièces sous garantie.

Consideraciones para la instalación

- Para obtener mejores resultados, la instalación debe estar a cargo de un plomero profesional matriculado.
- Antes de comenzar la instalación, lea estas instrucciones detenidamente. Asegúrese de tener las herramientas y los insumos necesarios para completar la instalación.
- Este grifo requiere un niple macho NPT de 1/2", que se extienda 1/2" hacia afuera de la superficie de la pared terminada.
- Instale los soportes para espárragos para la brida de montaje.

! Este grifo es para usar únicamente con agua fría.

- Mantenga este folleto y el recibo (u otro comprobante del lugar y fecha de compra) de este producto en lugar seguro. El recibo se requiere en caso de ser necesario solicitar piezas bajo garantía.

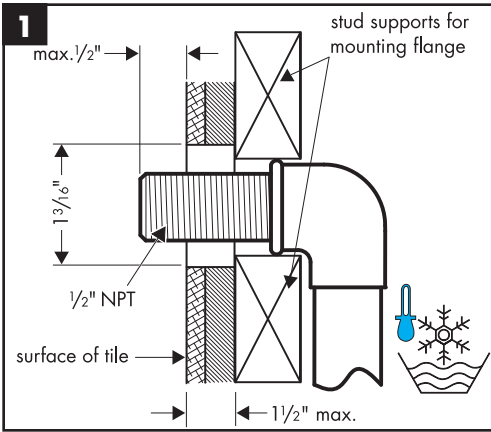

Roughing-in

This faucet requires a 1/2" NPT male nipple, extending 1/2" outside the surface of the finished wall.

Install stud supports for the mounting flange.

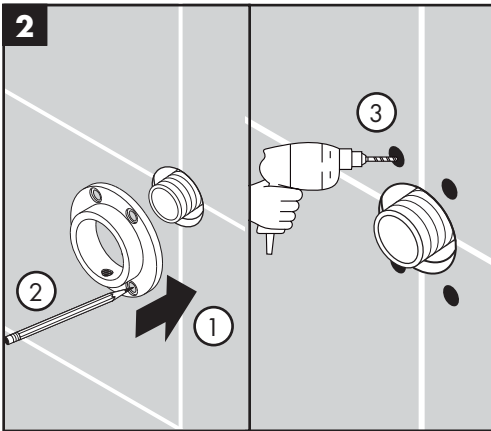

Installation

Position the mounting flange over the nipple.

Mark the positions of the screw holes.

Drill the screw holes.

! Do not drill into hidden electrical or plumbing lines.

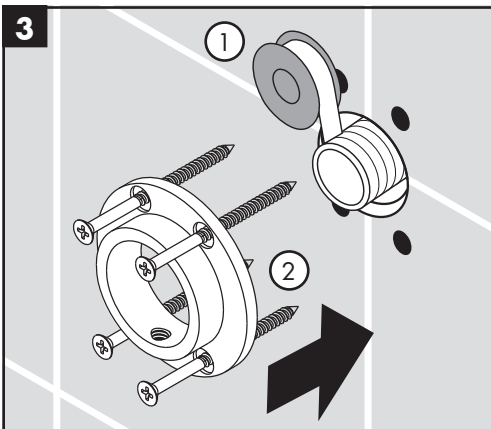

Wrap the threads on the nipple with Teflon tape.

Install the flange.

Pièce intérieure

Ce robinet requiert un raccord mâle fileté NPT de 1/2 po dont une partie de 1/2 po doit dépasser de la surface du mur fini.

Installez les supports de montant pour la bride de fixation.

Installation

Placez la bride de fixation sur le raccord fileté.

Marquez les positions des trous de vissage.

Percez les trous de vissage.



Assurez-vous de ne pas percer dans les câbles électriques ou conduits de plomberie dissimulés.

Enveloppez les filets sur le raccord fileté avec du ruban Téflon.

Installez la bride.

Piezas interiores

Este grifo requiere un niple macho NPT de 1/2", que se extienda 1/2" hacia afuera de la superficie de la pared terminada.

Instale los soportes para espárragos para la brida de montaje.

Instalación

Coloque la brida de montaje sobre el niple.

Marque las posiciones de los orificios para tornillos.

Perfore los orificios para los tornillos.



No perfore las tuberías eléctricas o de plomería escondidas.

Envuelva las roscas del niple con cinta de Teflon.

Instale la brida.

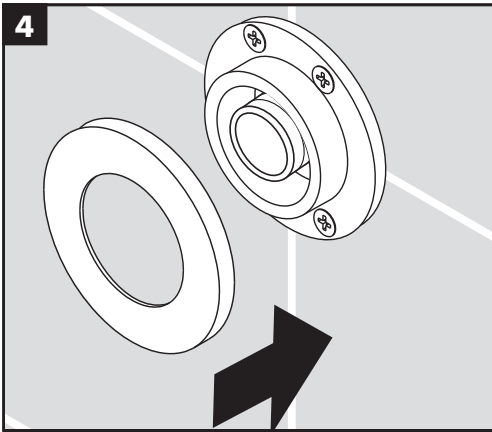

Install the escutcheon on the flange.

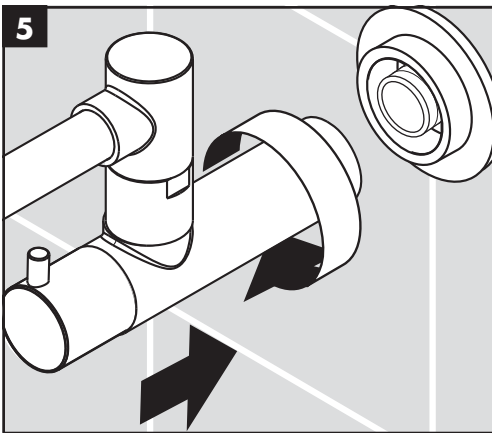

Install the faucet on the mounting nipple.

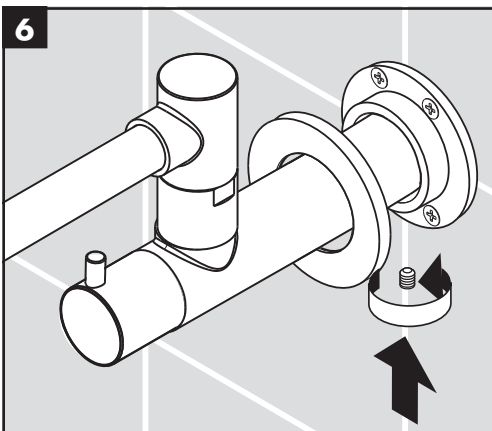

Push the escutcheon out of the way.

Tighten the screw.

Push the escutcheon against the wall.

If desired, seal the wall around the escutcheon using silicone sealant.



Do not use petroleum based putty.



ok!

Français

Installez l'écusson sur la bride.

Installez le robinet sur le raccord de fixation.

Déplacez l'écusson pour faire de l'espace.

Serrez la vis.

Poussez l'écusson contre le mur.

Si nécessaire, scellez le mur autour de l'écusson à l'aide d'un agent d'étanchéité à base de silicone.



N'utilisez pas de mastic à base de pétrole.

Español

Instale los escudos en la brida.

Instale el grifo en el niple de montaje.

Saque el escudo.

Apriete el tornillo.

Presione el escudo contra la pared.

Si lo desea, selle la pared alrededor del escudo con sellador de silicona.



No use masilla a base de petróleo.

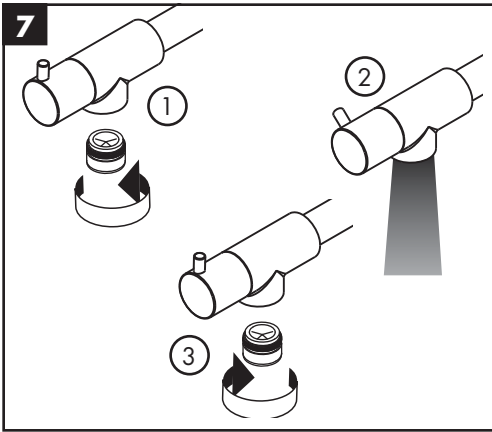

Remove the aerator.

Turn on the water.

Flush the faucet and check for leaks.

Turn the water off.

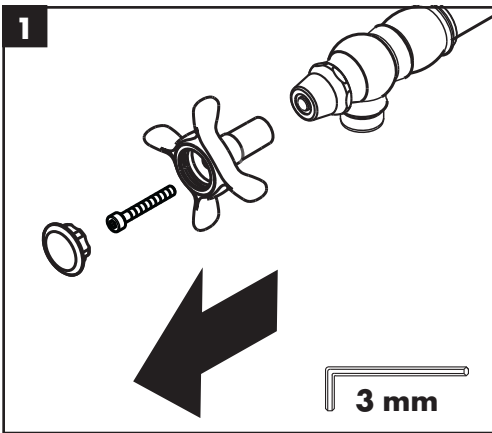

Change the handle (Optional - Montreux only)

Remove the screw cover, screw, and handle.

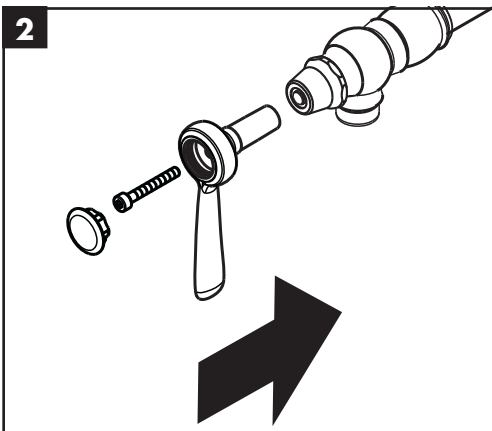

Install the new handle.

Install the handle screw and screw cover.

Français

Retirez l'aérateur.
Ouvrez l'eau.
Rincez le robinet et vérifiez s'il y a des fuites.
Fermez l'eau.

Español

Retire el aireador.
Abra el suministro de agua.
Lave el grifo y verifique para asegurarse de que no haya pérdidas.
Cierre el suministro de agua.

Changement de poignée (Étape optionnelle - Montreux uniquement)

Retirez le cache-vis, la vis et la poignée.

Installez la nouvelle poignée.
Installez la vis de poignée et le cache-vis.

Cambiar la manija (Opcional - sólo para Montreux)

Retire la tapa del tornillo, el tornillo y la manija.

Instale la manija nueva.
Instale el tornillo de la manija y la tapa del tornillo.

User Instructions / Instructions de service / Manejo

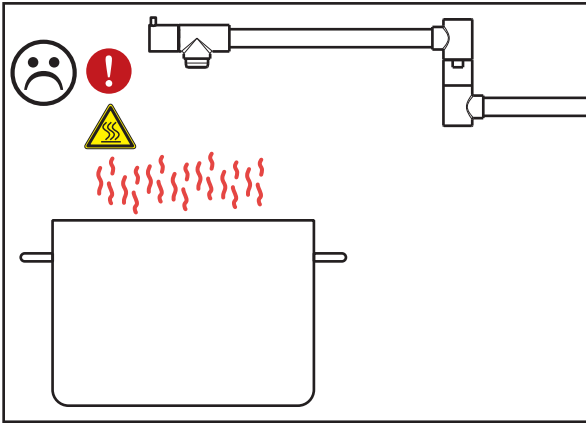
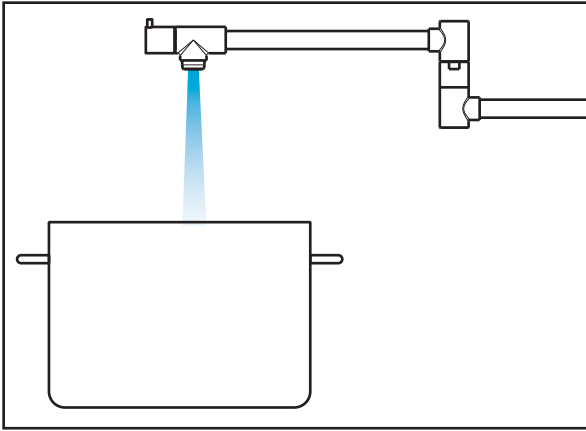

! Caution: Risk of Injury

The pot filler may become hot when the arm is positioned above a hot stove burner.

Always push the pot filler away from the burner after use.

! Attention : Risque de blessure

Le robinet remplisseur peut devenir chaud lorsque le bras est placé au-dessus d'un brûleur de cuisinière activé.

Éloignez toujours le robinet remplisseur du brûleur après l'utilisation.

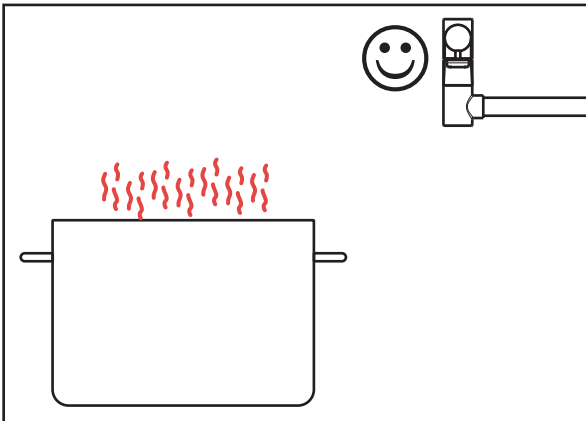

! Precaución: Riesgo de lesión

El grifo para cacerolas puede calentarse cuando el brazo se coloca sobre un quemador de cocina caliente.

Siempre aparte el grifo para cacerolas del quemador luego de usarlo.

Replacement Parts / Pièces détachées / Repuestos

Montreux

16859xx1

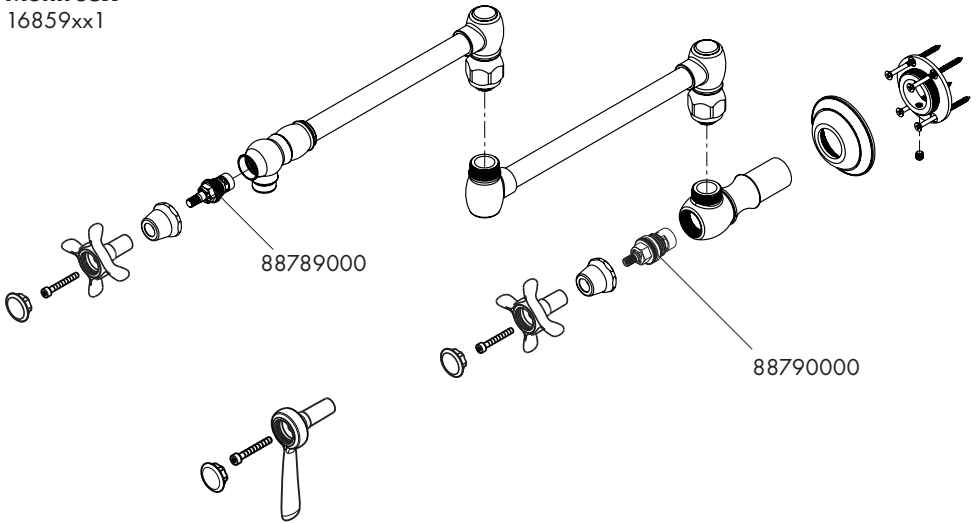

Starck

10859xx1

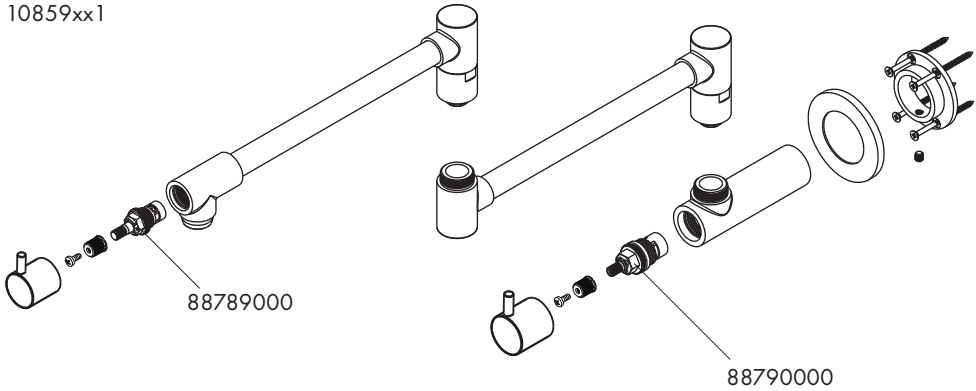

xx = Colors / Couleurs / Acabados

00 = Chrome

80 = Steel Optik

82 = Brushed Nickel

Citterio
39834xx1

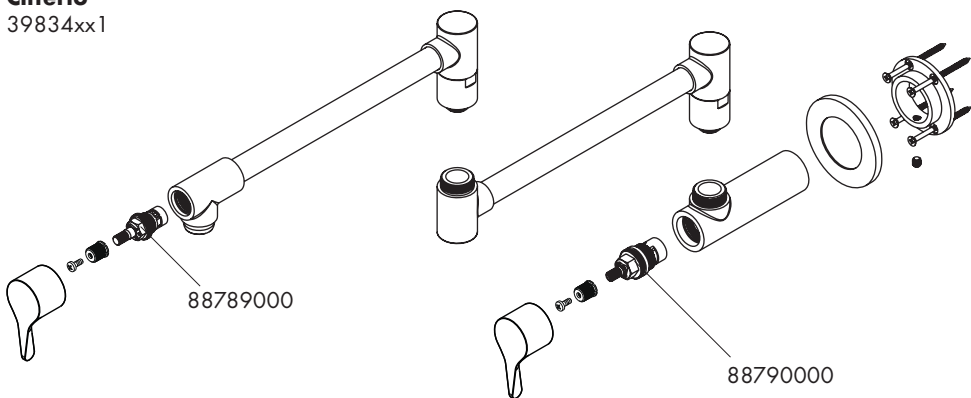

xx = Colors / Couleurs / Acabados

00 = Chrome

82 = Brushed Nickel

Cleaning Recommendation for Hansgrohe Products

Modern bathroom faucets, kitchen faucets and shower products are made from different materials to comply with the needs of the market with regard to design and functionality. To avoid damage to the product, it is necessary to take proper care of it.

For best results:

- Prevent the buildup of mineral scale and /or soap residue by cleaning your Hansgrohe product(s) when needed.
- Select a cleaning agent specifically intended for the type of product.
- **Do not** use these types of cleaners as they will cause damage to your Hansgrohe product:
 - ✘ Any cleaning agent containing hydrochloric acid, formic acid, lye, or acetic acid.
 - ✘ Abrasive cleaning powders, pads, or brushes.
 - ✘ Steam cleaners.
 - ✘ "No rinse" cleaning agents.
- **Always** follow the instructions provided by the manufacturer of the cleaning agent.
- **Do not** mix cleaning agents, unless directed by the manufacturer.
- **Do not** spray cleaners directly onto the product as drops could enter openings and gaps and cause damage. When using spray cleaners, spray the cleaner onto a soft cloth or sponge.
- **Always** rinse your Hansgrohe product thoroughly with clear water and polish dry with a soft cloth after cleaning.

Important

- Residue from soaps and shampoos can cause damage. Rinse the product with clean water after each use.
- Residue from basin/tub/tile cleaner can cause damage to faucets and fittings. Immediately rinse any overspray from the Hansgrohe product.
- **Damage to the product caused by improper care or the use of improper cleaning agents is not covered by the warranty.**
- **If a component of the product is damaged, replace it, as there is risk of injury.**

Conseil de nettoyage pour les produits Hansgrohe

De nos jours le sanitaire moderne, la robinetterie et les douchettes se composent de matériaux très différents pour satisfaire à la demande concernant le design et la fonctionnalité. Pour éviter les détériorations et les réclamations, aussi bien pour l'utilisation que pour le nettoyage prochain, certains critères seront à prendre en considération.

A prendre en considération lors de l'entretien de la robinetterie et de douchettes:

- On doit seulement utiliser les produits de nettoyage qui sont formellement prévus pour ce domaine.
- Aucun contact avec l'application de nettoyeurs contenant de l'acide chlorhydrique, de l'acide formique ou de l'acide acétique qui peuvent causer de considérables détériorations.
- Les nettoyeurs à base d'acide phosphorique, aussi, ne sont pas à utiliser sans réserves.
- Le mélange de nettoyeurs en général n'est pas autorisé.
- L'utilisation de produits de nettoyage récurants et des ustensiles comme des frottoirs, des éponges à récurer et des torchons microfibrés est exclue.
- Les conseils d'entretien des producteurs de nettoyeurs sont à suivre obligatoirement.
- Le nettoyage est à faire correspondre avec le dosage, le temps d'action, spécifique à l'objet et à la nécessité.
- Le dépôt de calcaire est évité par un nettoyage régulier.
- Pour le nettoyage avec produit vaporisé liquide, en aucun cas sur la robinetterie, mais au contraire aspergé sur

le chiffon (torchon, éponge) et effectuer comme cela le nettoyage, car les aérosols peuvent pénétrer dans les ouvertures et fentes de la robinetterie et peuvent provoquer des détériorations.

- Après le nettoyage rincez avec suffisamment d'eau claire pour éliminer les restes de produits attachés.
- L'utilisation d'appareil de nettoyage à vapeur n'est pas autorisée, car les températures importantes peuvent détériorer les produits.

Indications importantes

- Les produits pour le corps comme les savons liquides, les shampooings ou les gels de douche peuvent causer des détériorations.
- Ici aussi on doit: Après l'utilisation rincer soigneusement les restes avec de l'eau.

Conseil de nettoyage

- **Les deteriorations imputables à un mauvais entretien ne peuvent être pris en considération par notre garantie.**
- Par l'action d'un nettoyant sur les revêtements déjà endommagé il se produit une aggravation des dégâts.

Recomendación de limpieza para los productos de Hansgrohe

Hoy en día, las griferías de baño y de cocina así como duchas modernas se componen de materiales muy distintos para satisfacer las exigencias del mercado respecto al diseño y la funcionalidad. Para evitar daños y reclamaciones hay que tener en cuenta ciertos aspectos tanto en el uso como en su limpieza.

Para el cuidado de las griferías y las duchas en principio hay que seguir lo siguiente:

- Usar sólo detergentes previstos específicamente para este campo de aplicación.
- No aplicar detergentes que contengan ácido clorhídrico, fórmico o acético porque pueden causar daños importantes.
- Detergentes que contienen ácido fosfórico tampoco pueden ser aplicados ilimitadamente. Por regla general no se deben mezclar detergentes.
- Tampoco se deben utilizar utensilios abrasivos, como son polvos abrasivos, esponjas o paños de microfibra.
- Se tienen que seguir siempre las sugerencias de empleo de los fabricantes de los detergentes.
- La limpieza tiene que ser realizada según la dosificación y el tiempo de actuación, en función del objeto y ajustada a las necesidades específicas del mismo.
- Gracias a una limpieza periódica se pueden evitar los depósitos de cal.
- No conviene rociar el detergente en ningún caso sobre la grifería sino sobre los textiles y ejecutar la limpieza así, porque el líquido puede entrar en aperturas o hendiduras de la grifería y causar daños.
- Después de la limpieza hay que aclarar con suficiente agua para eliminar completamente el resto de detergente.
- La utilización de limpiadores a vapor no está permitida, las altas temperaturas pueden dañar los productos.

Indicaciones importantes

- Los residuos de productos de aseo como jabón líquido, champú y gel de ducha pueden dañar también los materiales.
- Por lo que también se deberá prestar atención a lo siguiente: aclarar con abundante agua después del uso.
- Con materiales ya dañados la acción de detergentes incrementará el desgaste de estos.
- **Los componentes con superficies dañadas deberán cambiarse, en otro caso se corre el peligro de lesionarse.**
- Los daños que resulten de un uso inadecuado no están incluidos en nuestra garantía.

Limited Consumer Warranty

This product has been manufactured and tested to the highest quality standards by Hansgrohe, Inc. (“Hansgrohe”). This warranty is limited to Hansgrohe products that are purchased by a consumer in the United States or Canada after March 1, 1996, and installed in either in the United States or in Canada.

WHO IS COVERED BY THE WARRANTY

This warranty extends to the original purchaser only. This warranty is non-transferable.

WHAT IS COVERED BY THE WARRANTY

The warranty covers only your Hansgrohe manufactured product. Hansgrohe warrants this product against defects in material or workmanship as follows:

Hansgrohe will replace at no charge for parts only or, at its option, replace any product or part of the product that proves defective because of improper workmanship and/or material, under normal installation, use, service and maintenance. If Hansgrohe is unable to provide a replacement and repair is not practical or cannot be made in timely fashion, Hansgrohe may elect to refund the purchase price in exchange for the return of the product.

LENGTH OF WARRANTY

Replacement or repaired parts of products will be covered for the term of this warranty, as stated in the following two sentences. If you are a consumer who purchased the product for use primarily for personal, family or household purposes, this warranty extends for as long as you own the product and the home in which the product is originally installed. If you purchased the product for use primarily for any other purpose, including, without limitation, a commercial purpose, this warranty extends only (i) for 1 year, with respect to Hansgrohe & Commercial products, and (ii) for 5 years, with respect to Axor products.

THIS WARRANTY DOES NOT COVER, AND HANSGROHE WILL NOT PAY FOR:

- A. Conditions, malfunctions or damage not resulting from defects in material or workmanship.
- B. Conditions, malfunctions or damage resulting from (1) normal wear and tear, improper installation, improper maintenance, misuse, abuse, negligence, accident or alteration; (2) the use of abrasive or caustic cleaning agents or “no-rinse” cleaning products, or the use of the product in any manner contrary to the product instructions; or (3) conditions in the home such as excessive water pressure or corrosion.
- C. Labor and other expenses for disconnection, deinstallation, or return of the product for warranty service (including but not limited to proper packaging and shipping costs), or for installation or reinstallation of the product.
- D. Accessories, connected materials and products, or related products not manufactured by Hansgrohe.
- E. Any Hansgrohe or Axor product sold for display purposes.
- F. Rubbed Bronze finish is subject to a 3-year limited warranty. Chrome and all PVD finishes are covered by the limited lifetime warranty.
- G. Hansgrohe Water Filtration System is subject to a 1-year limited warranty. Warranty does not include replacement filters.

TO OBTAIN WARRANTY PARTS OR INFORMATION

Contact your Hansgrohe retailer, or contact Technical Service at:

Hansgrohe, Inc.
1492 Bluegrass Lakes Parkway
Alpharetta, GA 30004
Toll-free 800-334-0455

In requesting warranty service, you will need to provide:

1. The sales receipt or other evidence of the date and place of purchase.
2. A description of the problem.
3. Delivery of the product or the defective part, postage prepaid and carefully packed and insured, to:
Hansgrohe, Inc.

1492 Bluegrass Lakes Parkway
Alpharetta, GA 30004
Toll-free 800-334-0455

When warranty service is completed, any repaired or replacement product or part will be returned to you postage prepaid.

EXCLUSIONS AND LIMITATIONS

REPAIR OR REPLACEMENT (OR, IN LIMITED CIRCUMSTANCES, REFUND OF THE PURCHASE PRICE) AS PROVIDED UNDER THIS WARRANTY IS THE EXCLUSIVE REMEDY OF THE PURCHASER. HANSGROHE NEITHER ASSUMES NOR AUTHORIZES ANY PERSON TO CREATE FOR IT ANY OTHER OBLIGATION OR LIABILITY IN CONNECTION WITH THIS PRODUCT. HANSGROHE SHALL NOT BE LIABLE TO PURCHASER OR ANY OTHER PERSON FOR ANY INCIDENTAL, SPECIAL OR CONSEQUENTIAL DAMAGES, ARISING OUT OF BREACH OF THIS WARRANTY OR ANY IMPLIED WARRANTY (INCLUDING BUT NOT LIMITED TO ANY IMPLIED WARRANTY OF MERCHANTABILITY).

Some States do not allow the exclusion or limitation of incidental or consequential damages, so the above limitation or exclusion may not apply to you. This warranty gives you specific legal rights, and you may also have other rights that vary from state to state.

TO THE EXTENT PERMITTED BY LAW, ANY IMPLIED WARRANTIES OF MERCHANTABILITY AND FITNESS FOR A PARTICULAR PURPOSE, ARE LIMITED TO THE DURATION OF THE EXPRESS WARRANTY.

Some states do not allow limitations on how long an implied warranty may last, so the above limitations may not apply to you. You may be required by law to give us a reasonable opportunity to correct or cure any failure to comply before you can bring any action in court against us under the Magnuson-Moss Warranty Act.

PRODUCT INSTRUCTIONS AND QUESTIONS

Upon purchase or prior to installation, please carefully inspect your Hansgrohe product for any damage or visible defect. Prior to installing, always carefully study the enclosed instructions on the proper installation and the care and maintenance of this product. If you have questions at any time about the use, installation or performance of your Hansgrohe product, or this warranty, please write us or call us toll-free at 800-334-0455.

hansgrohe

Hansgrohe, Inc. • 1490 Bluegrass Lakes Parkway • Alpharetta, GA 30004
Tel. 800-334-0455 • Fax 770-360-9887

www.hansgrohe-usa.com