

# AXOR<sup>®</sup>

**hansgrohe**

- EN** Installation / User Instructions / Warranty
- FR** Instructions de montage / Mode d'emploi / Garantie
- ES** Instrucciones de montaje / Manejo / Garantía

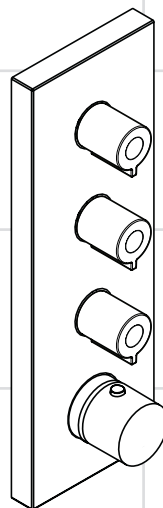

**Starck**  
10751xx1

## Technical Information

Recommended water pressure	15 - 75 PSI
Max. water pressure	145 PSI
Recommended hot water temp.	120° - 140° F*
Max. hot water temp	176° F*
Flow rate	max.14.5 GPM

\* Please know and follow all applicable local plumbing codes when setting the temperature on the water heater.

## Installation Considerations

- For best results, Hansgrohe recommends that this unit be installed by a licensed, professional plumber.
- Please read over these instructions thoroughly before beginning installation. Make sure that you have all tools and supplies needed to complete the installation.
- This trim is for use with rough valve 10750181 (not included).
- To prevent scald injury, the maximum output temperature of the shower mixing valve (not included) must be no higher than 120°F. In Massachusetts, the maximum output temperature can be no higher than 112° F.
- This product is for use with shower heads rated at 2.5 GPM (9.5 l/min) or higher.
- Keep this booklet and the receipt (or other proof of date and place of purchase) for this product in a safe place. The receipt is required should it be necessary to request warranty parts.

## Données techniques

Pression d'eau recommandée	15 - 75 PSI
Pression d'eau maximum	145 PSI
Température recommandée d'eau chaude	120° - 140° F*
Température maximum d'eau chaude	176° F*
Capacité nominale	14.5 GPM

\* Vous devez connaître et respecter tous les codes de plomberie locaux applicables pour le réglage de la température du chauffe-eau.

## À prendre en considération pour l'installation

- Pour de meilleurs résultats, Hansgrohe recommande que ce produit soit installé par un plombier professionnel licencié.
- Veuillez lire attentivement ces instructions avant de procéder à l'installation. Assurez-vous de disposer de tous les outils et du matériel nécessaires pour l'installation.
- Ce dispositif requiert une pièce intérieure 10750181.
- Pour empêcher des blessures par ébouillement, la température de sortie maximale du robinet de douche ne doit pas excéder 120°F. Au Massachusetts, la température de sortie maximale du robinet de douche ne doit pas excéder 112° F.
- Ce mitigeur thermostatique est à utiliser avec des pommes de douches ayant un débit de 9.5 L/min (2.5 GPM) ou supérieur.
- Conservez ce livret et le reçu (ou une autre preuve sur laquelle figurent la date et l'endroit de l'achat) pour ce produit dans un endroit sûr. Le reçu est requis si vous commandez des pièces sous garantie.



This unit meets or exceeds the following:

- ASME A112.18.1
- CSA B125.1
- Listed by IAPMO for use in the US and Canada

## Datos técnicos

Presión recomendada en servicio	15 - 75 PSI
Presión en servicio max.	145 PSI
Temperatura recomendada del agua caliente	120° - 140° F*
Temperatura del agua caliente max.	176° F*
Caudal máximo	14.5 GPM

\*Debe conocer y cumplir todos los códigos locales aplicables para ajustar la temperatura del calentador de agua.

## Consideraciones para la instalación

- Para obtener mejores resultados, la instalación debe estar a cargo de un plomero profesional matriculado.
- Antes de comenzar la instalación, lea estas instrucciones detenidamente. Asegúrese de tener las herramientas y los insumos necesarios para completar la instalación.
- La unidad requiere una pieza interior de válvula 10750181.
- Para evitar escaldaduras, la máxima temperatura de salida de la válvula de la ducha no debe exceder los 120° F. En Massachusetts, la máxima temperatura de salida de la válvula de la ducha no debe exceder los 112° F.
- El mezclador termostático está diseñado para uso con cabezales de ducha calificados a 9.5 L/min (2.5 GPM) o más.
- Mantenga este folleto y el recibo (u otro comprobante del lugar y fecha de compra) de este producto en lugar seguro. El recibo se requiere en caso de ser necesario solicitar piezas bajo garantía.

## Tools Required / Outils Utiles / Herramientas Utiles

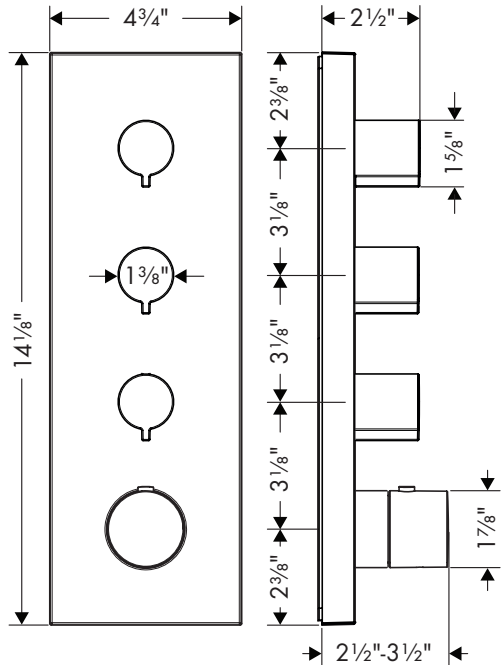
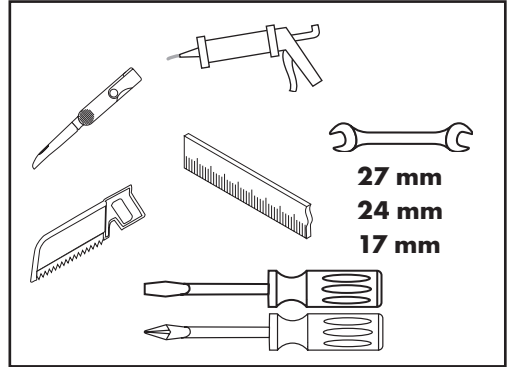

## Installation / Installation / Instalación

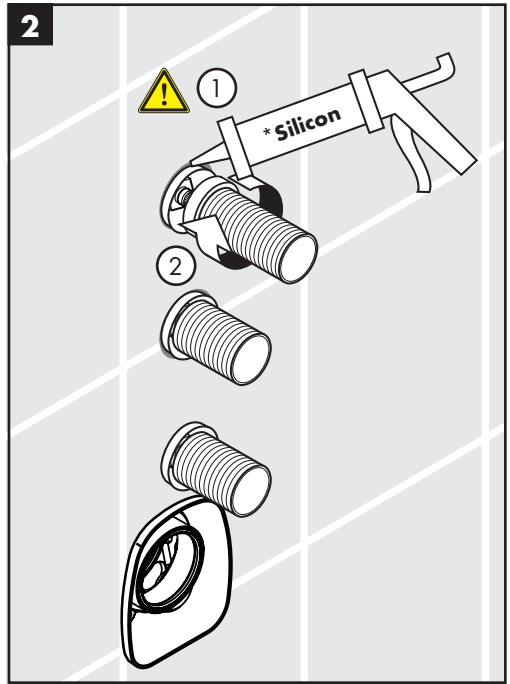
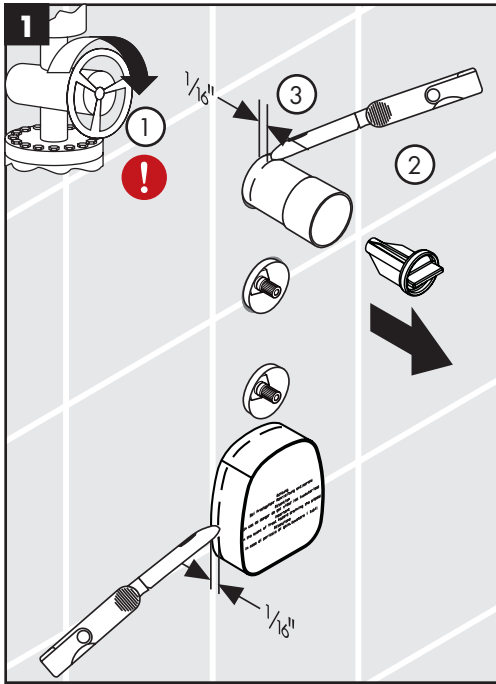

### English

**!** Turn the water off at the main.

Cut the plaster shields so that they extend 1/16" outside the surface of the finished wall.

Seal the wall around the plaster shields using waterproof sealant.

**!** Failure to seal the wall may lead to water damage.

Install the slip connectors.

### Français

**!** Fermez l'eau à la valve principale.

Coupez le protecteur de façon à ce qu'une partie de 1/16 po à 1/8 po soit à l'extérieur de la surface du mur fini.

Scellez le mur autour du protecteur à l'aide d'un agent d'étanchéité.

**!** Si le mur n'est pas scellé, l'eau pourrait éventuellement causer des dommages.

Installez les raccords à glissements.

### Español

**!** Cierre el paso del agua en la entrada del suministro.

Corte el protector de yeso de modo que sobresalga 1/16" de la superficie de la pared terminada.

Selle la pared alrededor del protector de yeso con un sellador impermeable.

**!** Si no se sella la pared, pueden producirse daños por acción del agua.

Instale el acoplamiento deslizante.

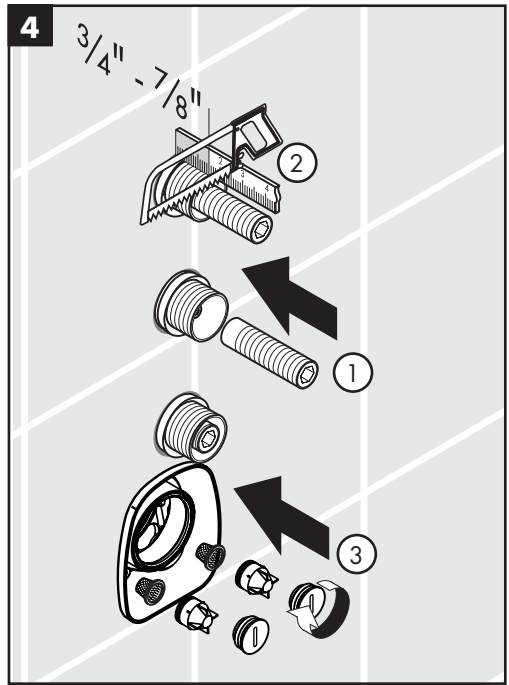
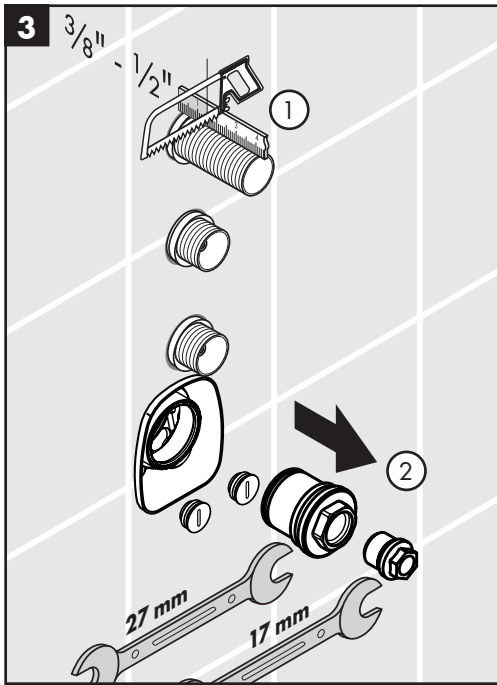

## English

Cut the slip connector so that it extends  $\frac{3}{8}$ " -  $\frac{1}{2}$ " outside the surface of the finished wall.

Remove the insert, plug, and check valve covers from the thermostatic mixer.

Install the extension spindles.

Cut the spindles so that they extend  $\frac{3}{4}$ " -  $\frac{7}{8}$ " outside the surface of the finished wall.

Install the check valves. Install the check valve covers.

## Français

Coupez les raccords à glissements de façon à ce qu'une partie de  $\frac{3}{8}$  -  $\frac{1}{2}$  po soit à l'extérieur de la surface du mur fini.

Retirez la pièce d'insertion, le bouchon, et les couvercles de les clapets de non-retours.

Installez les tiges d'extension.

Coupez les tiges d'extension de façon à ce qu'une partie de  $\frac{3}{4}$  -  $\frac{7}{8}$  po soit à l'extérieur de la surface du mur fini.

Installez les clapets de non-retours. Installez les couvercles.

## Español

Corte el acoplamiento deslizante de modo que sobresalga  $\frac{3}{8}$ " -  $\frac{1}{2}$ " de la superficie de la pared terminada.

Retire el inserto, el tapón, y las tapas de válvulas de retención.

Instale los husillos de extensión.

Corte los husillos de extensión de modo que sobresalga  $\frac{3}{4}$ " -  $\frac{7}{8}$ " de la superficie de la pared terminada.

Instale las válvulas de retención. Instale las tapas.

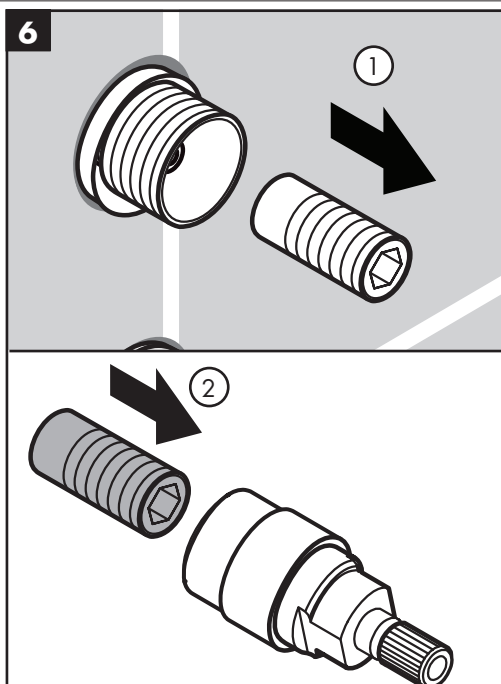
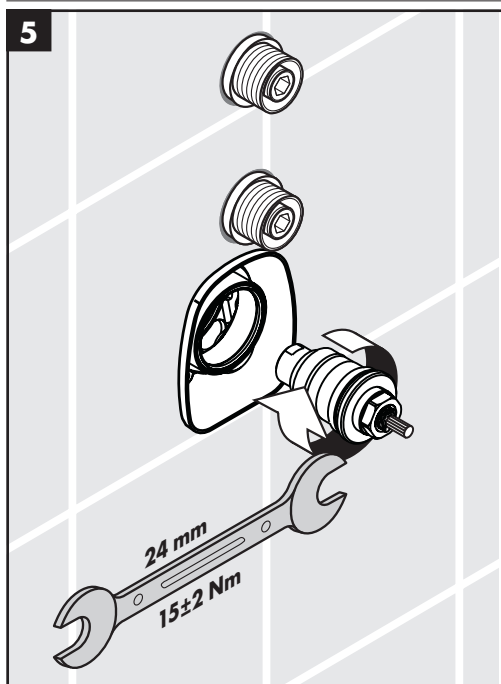

**English**

Install the thermostatic cartridge.

Push the extension spindles into the volume control sleeves.

**Français**

Installez la cartouche thermostatique.

Poussez le tige d'extension dans le manchon pour les réglages de débit.

**Español**

Instale el cartucho termostático.

Empuje el husillo de extensión en el manguito para la llave de paso.

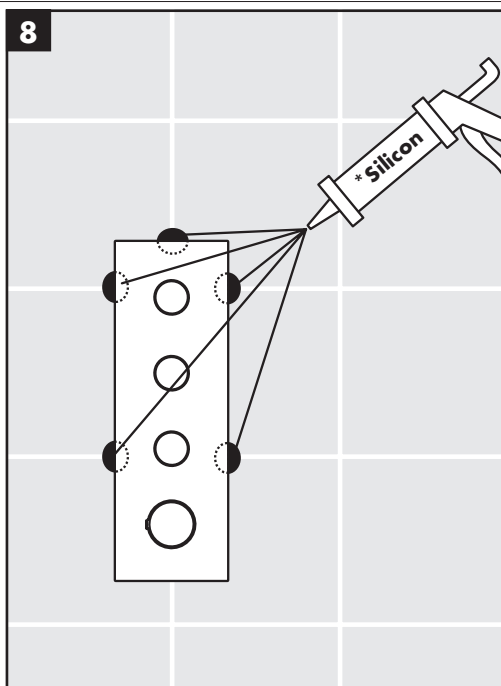
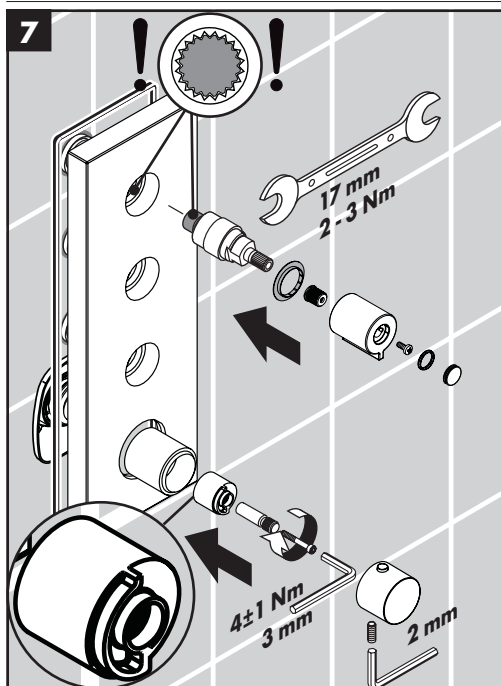

## English

Push the trim plate against the wall.

Install the volume control sleeves.

Install the snap connectors.

Install the handles. Tighten the screws. Install the o-rings and screw covers.

Install the thermostatic mixer sleeve, stop ring, and stem extension.

Install the thermostatic mixer handle.

Place a dab of waterproof sealant on the wall at the grout joints.

## Français

Poussez l'écusson contre le mur.

Installez les adaptateurs pour les poignées.

Installez les connecteurs à encliqueter.

Installez les poignées.

Installez les caches-vis.

Installez la douille pour la poignée thermostique, la bague de butée, et l'adaptateur pour poignée.

Installez la poignée thermostatique.

Appliquez une petite quantité d'un agent d'étanchéité aux joints de coulis sur le dessus et les côtés.

## Español

Presione el escudo contra la pared.

Instale los manguitos para las llaves de paso.

Instale los anclajes para las manijas.

Instale las manijas.

Instale los tapones.

Instale el manguito de la válvula termostática, el aro de tope, y el adaptador manija.

Instale la manija termostática.

Coloque un poco de sellador a prueba de agua en las uniones de la lechada de cemento.

Set the high temperature limit stop / Réglage de la butée limite d'eau chaude / Ajuste el tope de limite de alta temperatura

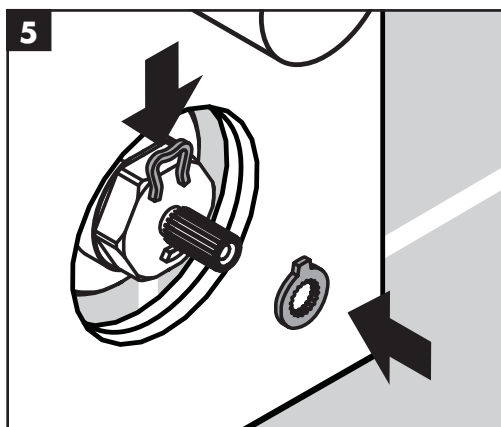
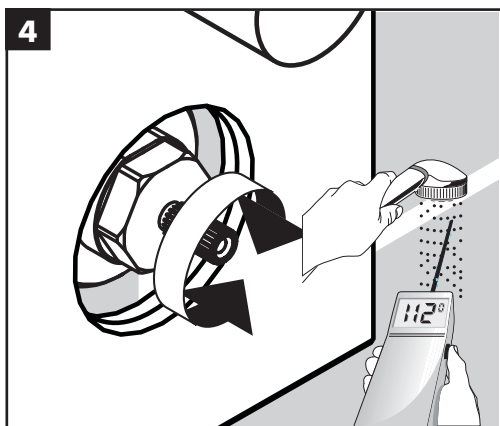
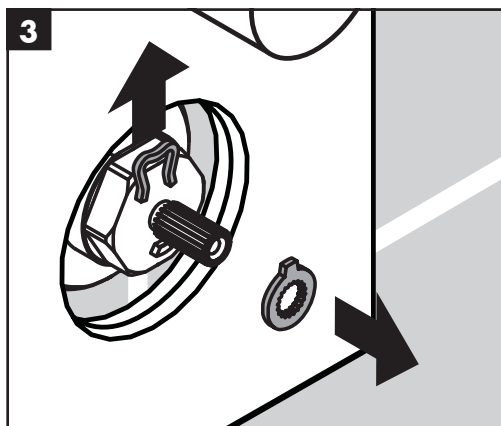
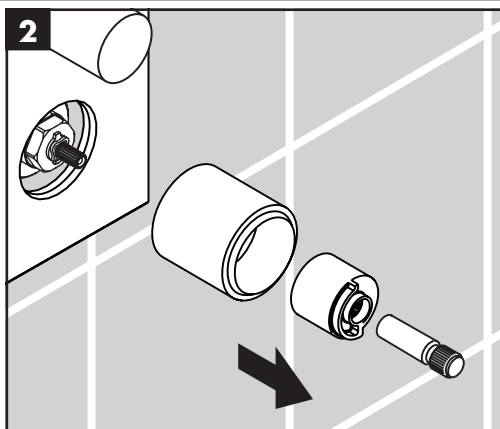
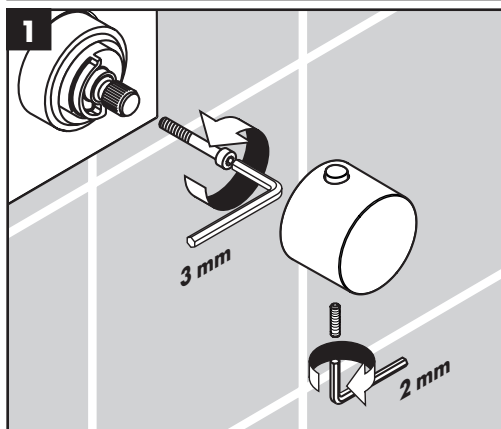



Justify the handle / Réglez la poignée / Ajuste la manija

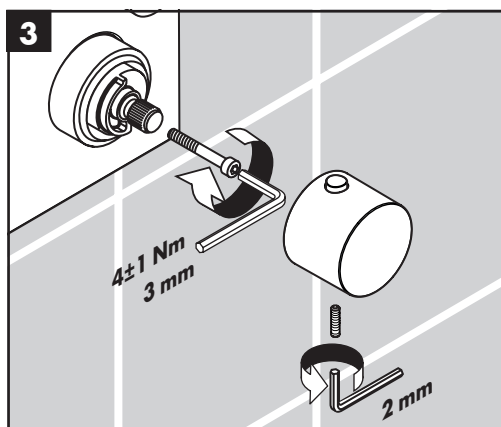
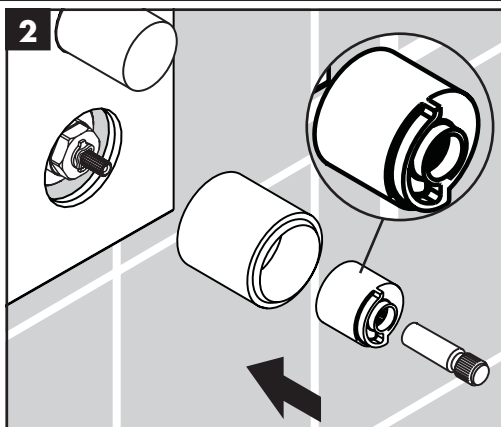
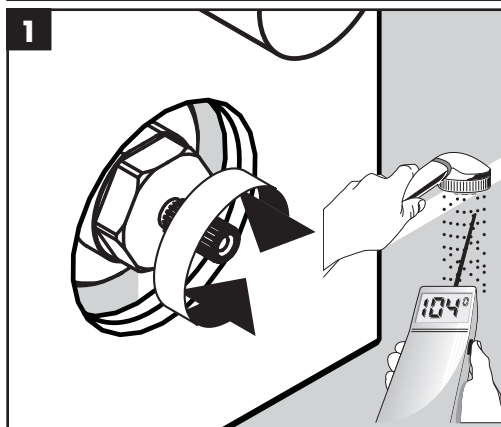

# Replacement Parts / Pièces détachées / Repuestos

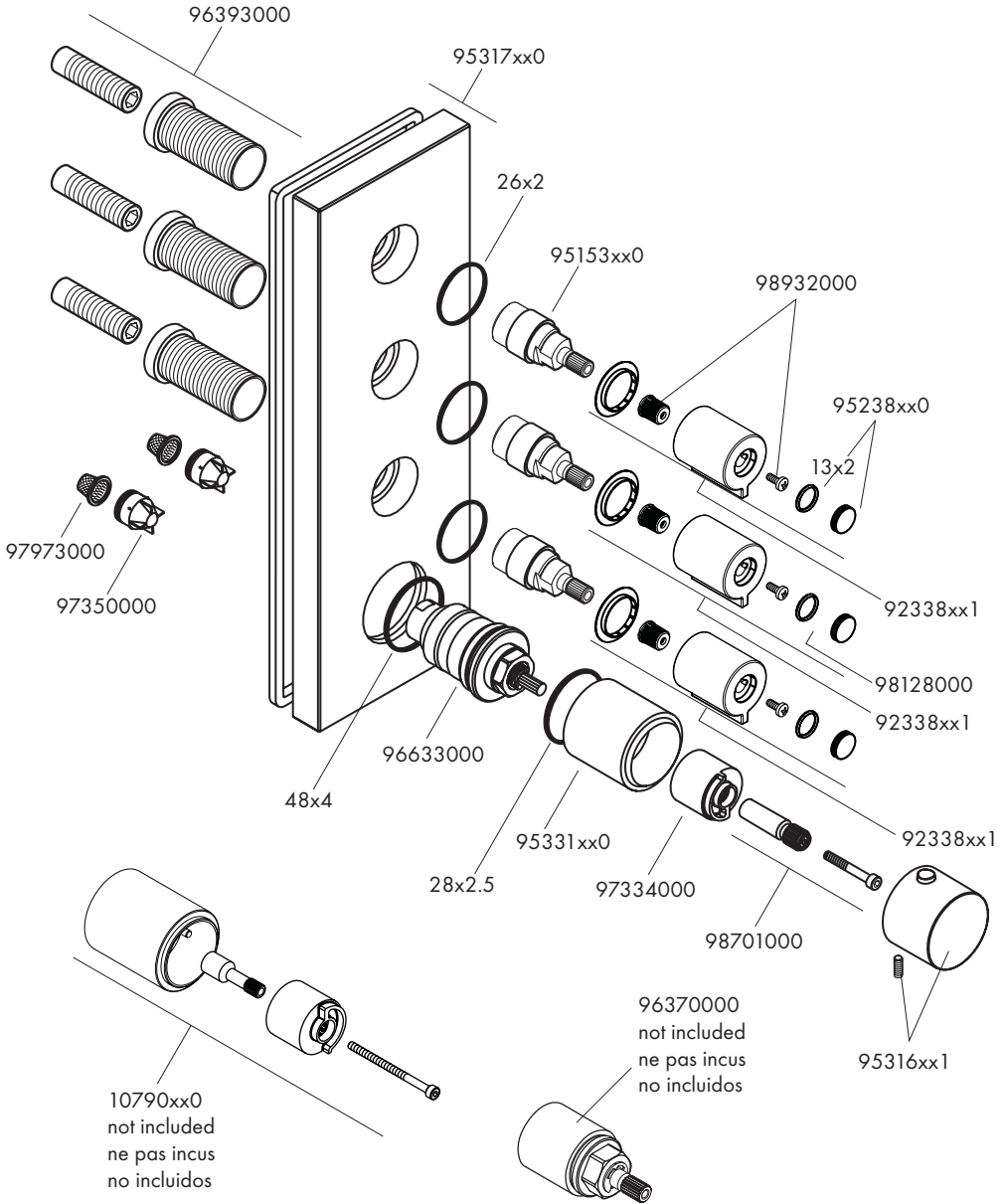

## xx = Colors / Couleurs / Acabados

00 = Chrome

82 = Brushed Nickel

Cleaning / Nettoyage / Limpieza

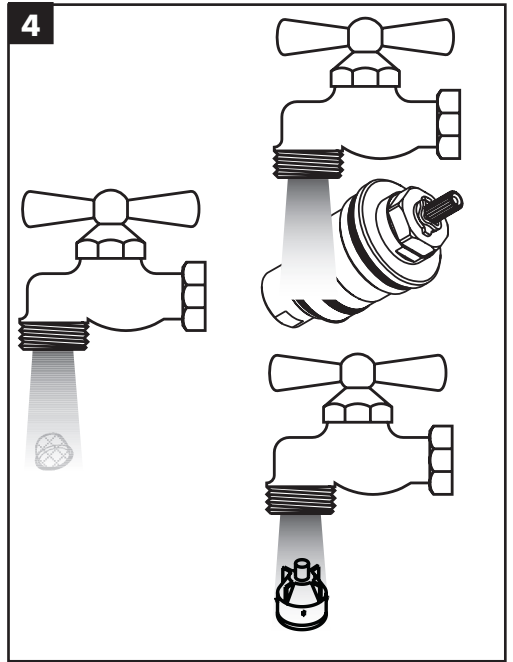
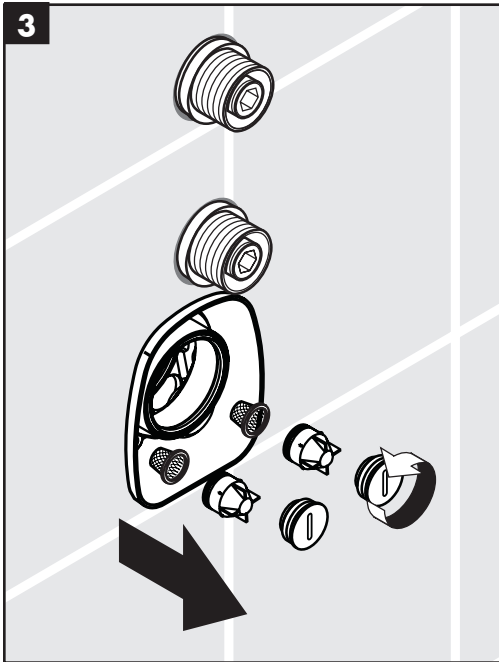
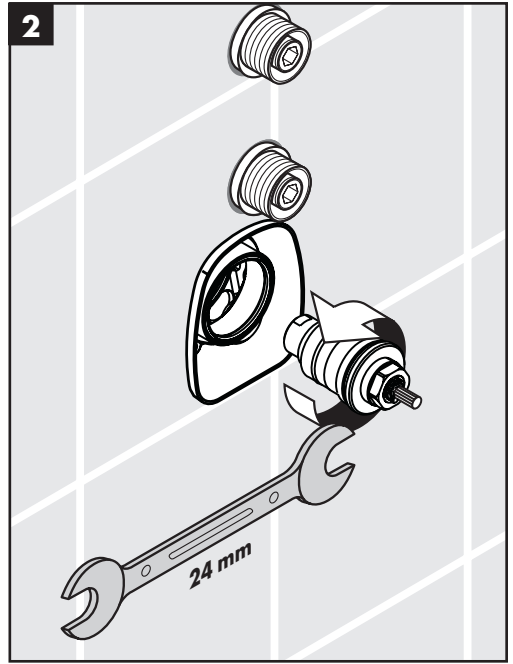
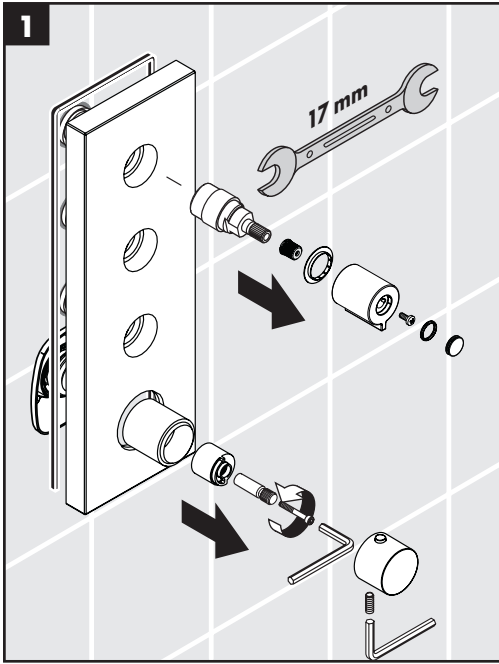

Cleaning / Nettoyage / Limpieza

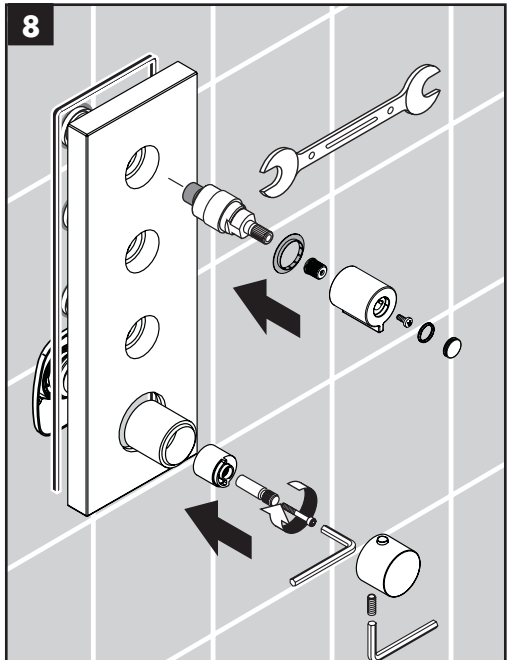
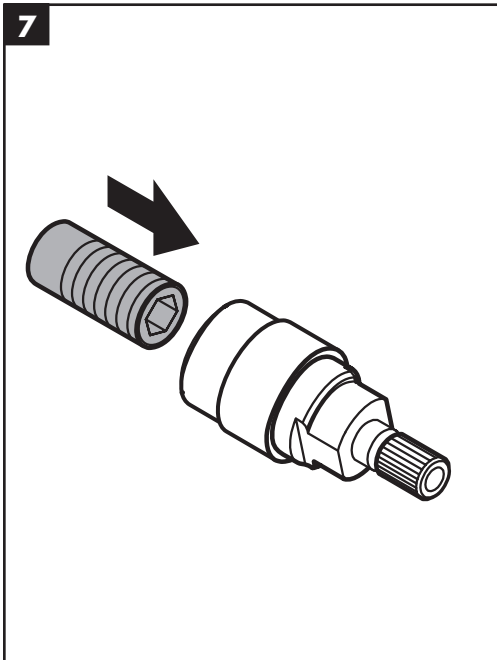
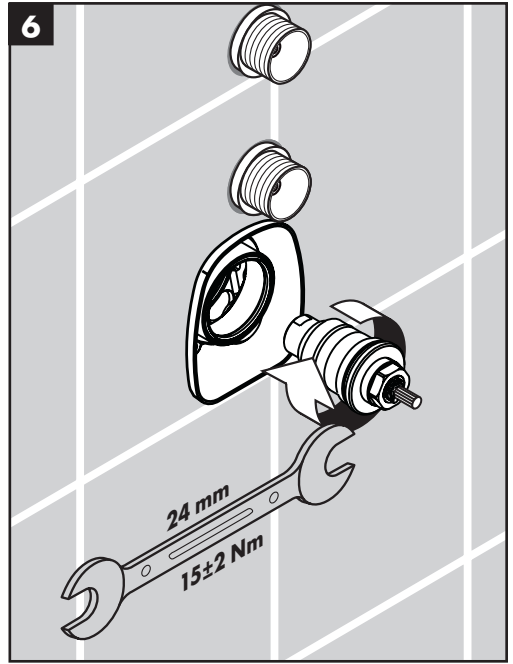
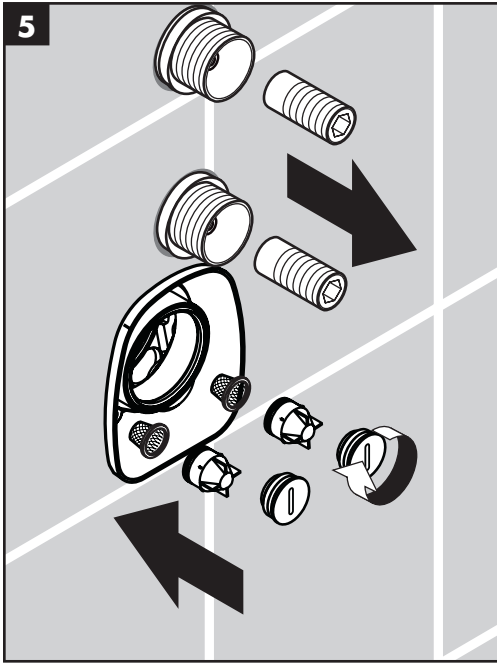

## Cleaning Recommendation for Hansgrohe Products

---

Modern bathroom faucets, kitchen faucets and shower products are made from different materials to comply with the needs of the market with regard to design and functionality. To avoid damage to the product, it is necessary to take proper care of it.

### For best results:

- Prevent the buildup of mineral scale and /or soap residue by cleaning your Hansgrohe product(s) when needed.
- Select a cleaning agent specifically intended for the type of product.
- **Do not** use these types of cleaners as they will cause damage to your Hansgrohe product:
  - ✗ Any cleaning agent containing hydrochloric acid, formic acid, lye, or acetic acid.
  - ✗ Abrasive cleaning powders, pads, or brushes.
  - ✗ Steam cleaners.
  - ✗ "No rinse" cleaning agents.
- **Always** follow the instructions provided by the manufacturer of the cleaning agent.
- **Do not** mix cleaning agents, unless directed by the manufacturer.
- **Do not** spray cleaners directly onto the product as drops could enter openings and gaps and cause damage. When using spray cleaners, spray the cleaner onto a soft cloth or sponge.
- **Always** rinse your Hansgrohe product thoroughly with clear water and polish dry with a soft cloth after cleaning.

### Important

- Residue from soaps, shampoos, hair dye, and other toiletries and cosmetics can cause damage. Rinse the product with clean water after each use.
- Residue from basin/tub/tile cleaner can cause damage to faucets and fittings. Immediately rinse any overspray from the Hansgrohe product.
- Do not store any cleaning agents under your Hansgrohe product, such as in a vanity unit, as the fumes may damage the product.
- **Damage to the product caused by improper care or the use of improper cleaning agents is not covered by the warranty.**
- **If a component of the product is damaged, replace it, as there is risk of injury.**

## Conseil de nettoyage pour les produits Hansgrohe

Les robinets pour les salles de bains et les cuisines modernes ainsi que les produits récents pour les douches se composent de matériaux différents afin de satisfaire aux besoins du marché en termes de conception et de fonctionnalité. Afin d'éviter d'endommager le produit, il est nécessaire d'en prendre soin.

### Pour de meilleurs résultats :

- Empêchez l'accumulation de tarte et/ou de résidu de savon en nettoyant votre produit Hansgrohe lorsque c'est nécessaire.
- Sélectionnez un produit de nettoyage spécifiquement prévu pour ce type de produit.
- **N'utilisez pas** ces types de nettoyeurs car ils peuvent endommager votre produit Hansgrohe :
  - ✗ Tout produit de nettoyage contenant de l'acide chlorhydrique, de l'acide formique, de la potasse ou de l'acide acétique.
  - ✗ Les poudres de nettoyage, les tampons ou les brosses abrasives.
  - ✗ Les nettoyeurs à vapeur.
  - ✗ Les produits de nettoyage « sans rinçage ».
- **Ne mélangez pas** les produits de nettoyage, à moins que cela soit indiqué par le fabricant.

- 
- **Ne pulvérisez pas** los nettoyants directement sur le produit car des gouttes pourraient entrer dans les ouvertures et les fentes et causer des dommages. Lorsque vous utilisez des nettoyants par pulvérisation, pulvérisez le nettoyant sur un chiffon ou une éponge douce.

### Important

- Les residus de produits pour le corps comme les savons liquides, shampoings, gels de douche, teintures pour cheveux, parfums, apres-rasage et vernis a ongles peuvent causer des deteriorations. Rincez le produit avec de l'eau propre après chaque utilisation.
- Le résidu provenant des nettoyants pour cuvette/baignoire/carrelage peut endommager les robinets et les raccords de tuyauterie. Rincez immédiatement toute surpulvérisation sur le produit Hansgrohe.
- De meme, il est interdit de stocker des detergents ou des produits chimiques sous les produits, par ex. dans un meuble sous lavabo, car les vapeurs qui s'en degagent risquent d'abimer les produits.
- **Les dommages au produit causés par un mauvais entretien ou par l'utilisation de produits de nettoyage inadéquats ne sont pas couverts par la garantie.**
- **Si un composant du produit est endommagé, remplacez-le, car il existe un risque de blessure.**

## Recomendación de limpieza para los productos de Hansgrohe

Hoy en día, las griferías de baño y de cocina así como duchas modernas se componen de materiales muy distintos para satisfacer las exigencias del mercado respecto al diseño y la funcionalidad. Para evitar daños y reclamaciones hay que tener en cuenta ciertos aspectos tanto en el uso como en su limpieza.

### Para obtener mejores resultados:

- Evite la acumulación de restos de jabón o sarro limpiando el producto Hansgrohe cuando sea necesario.
- Seleccione un agente de limpieza diseñado específicamente para el tipo de producto.
- **No** use estos tipos de limpiadores, ya que causarán daño a su producto Hansgrohe:
  - ✘ Agentes limpiadores que contengan ácido clorhídrico, fórmico, acético o lejía.
  - ✘ Polvos, paños o cepillos de limpieza abrasivos.
  - ✘ Limpiadores a vapor
  - ✘ Agentes de limpieza "sin enjuague".
- **Siempre** siga las instrucciones provistas por el fabricante del agente de limpieza.
- **No** mezcle los agentes de limpieza, a menos que esté indicado por el fabricante.
- **No** rocíe limpiadores directamente sobre el producto, ya que podrían caer gotas sobre las aberturas y espacios y causar daños. Cuando use limpiadores en spray, rocíe el limpiador sobre un paño suave o esponja.
- **Siempre** enjuague su producto Hansgrohe con agua limpia y séquelo y lístrelolo con un paño suave después de la limpieza.

### Importante

- Los residuos de productos de aseo como jabon liquido, champus, gel de ducha, tintes de pelo, perfumes, lociones de afeitado y esmalte de unas pueden danar tambien los materiales. Enjuague el producto con agua limpia después de cada uso.
- Los residuos de limpiadores para lavatorios, bañeras o azulejos pueden causar daño a los grifos y accesorios. Enjuague inmediatamente cualquier derrame que haya sobre el producto de Hansgrohe.
- Tampoco pueden generarse depositos de productos de limpieza o quimicos debajo de los productos, p. ej. En un armario de lavabo. De lo contrario, los vapores generados pueden danar los productos.
- **Los daños que resulten de un cuidado inadecuado o uso de agentes de limpieza inadecuados no están cubiertos por la garantía.**
- **Si se daña un componente del producto, reemplácelo, ya que existe riesgo de lesión.**

## Limited Consumer Warranty

This product has been manufactured and tested to the highest quality standards by Hansgrohe, Inc. ("Hansgrohe"). This warranty is limited to Hansgrohe products that are purchased by a consumer in the United States or Canada after March 1, 1996, and installed in either the United States or in Canada.

### WHO IS COVERED BY THE WARRANTY

This warranty extends to the original purchaser only. This warranty is non-transferable.

### WHAT IS COVERED BY THE WARRANTY

The warranty covers only your Hansgrohe manufactured product. Hansgrohe warrants this product against defects in material or workmanship as follows:

Hansgrohe will replace at no charge for parts only or, at its option, replace any product or part of the product that proves defective because of improper workmanship and/or material, under normal installation, use, service and maintenance. If Hansgrohe is unable to provide a replacement and repair is not practical or cannot be made in timely fashion, Hansgrohe may elect to refund the purchase price in exchange for the return of the product.

### LENGTH OF WARRANTY

Replacement or repaired parts of products will be covered for the term of this warranty, as stated in the following two sentences. If you are a consumer who purchased the product for use primarily for personal, family or household purposes, this warranty extends for as long as you own the product and the home in which the product is originally installed. If you purchased the product for use primarily for any other purpose, including, without limitation, a commercial purpose, this warranty extends only (i) for 1 year, with respect to Hansgrohe & Commercial products, and (ii) for 5 years, with respect to Axor products.

### THIS WARRANTY DOES NOT COVER, AND HANSGRÖHE WILL NOT PAY FOR:

- A. Conditions, malfunctions or damage not resulting from defects in material or workmanship.
- B. Conditions, malfunctions or damage resulting from normal wear and tear, improper installation, improper maintenance, misuse, abuse, negligence, accident or alteration; the use of abrasive or caustic cleaning agents or "no-rinse" cleaning products, or the use of the product in any manner contrary to the product instructions; or conditions in the home such as excessive water pressure or corrosion.
- C. Labor and other expenses for disconnection, deinstallation, or return of the product for warranty service (including but not limited to proper packaging and shipping costs), or for installation or reinstallation of the product.
- D. Accessories, connected materials and products, or related products not manufactured by Hansgrohe.
- E. Any Hansgrohe or Axor product sold for display purposes.
- F. Hansgrohe Water Filtration System is subject to a 1-year limited warranty. Warranty does not include replacement filters.

### TO OBTAIN WARRANTY PARTS OR INFORMATION

Contact your Hansgrohe retailer, or contact Technical Service at:

Hansgrohe, Inc.  
1492 Bluegrass Lakes Parkway  
Alpharetta, GA 30004  
Toll-free 800-334-0455

In requesting warranty service, you will need to provide:

- 1. The sales receipt or other evidence of the date and place of purchase.
- 2. A description of the problem.
- 3. Delivery of the product or the defective part, postage prepaid and carefully packed and insured, to:

Hansgrohe, Inc.  
1492 Bluegrass Lakes Parkway  
Alpharetta, GA 30004  
Toll-free 800-334-0455

When warranty service is completed, any repaired or replacement product or part will be returned to you postage prepaid.

## Exclusions and Limitations

**REPAIR OR REPLACEMENT (OR, IN LIMITED CIRCUMSTANCES, REFUND OF THE PURCHASE PRICE) AS PROVIDED UNDER THIS WARRANTY IS THE EXCLUSIVE REMEDY OF THE PURCHASER. HANSGROHE NEITHER ASSUMES NOR AUTHORIZES ANY PERSON TO CREATE FOR IT ANY OTHER OBLIGATION OR LIABILITY IN CONNECTION WITH THIS PRODUCT.**

**HANSGROHE SHALL NOT BE LIABLE TO PURCHASER OR ANY OTHER PERSON FOR ANY INCIDENTAL, SPECIAL OR CONSEQUENTIAL DAMAGES, ARISING OUT OF BREACH OF THIS WARRANTY OR ANY IMPLIED WARRANTY (INCLUDING BUT NOT LIMITED TO ANY IMPLIED WARRANTY OF MERCHANTABILITY).**

Some States do not allow the exclusion or limitation of incidental or consequential damages, so the above limitation or exclusion may not apply to you. This warranty gives you specific legal rights, and you may also have other rights that vary from state to state.

**TO THE EXTENT PERMITTED BY LAW, ANY IMPLIED WARRANTIES OF MERCHANTABILITY AND FITNESS FOR A PARTICULAR PURPOSE, ARE LIMITED TO THE DURATION OF THE EXPRESS WARRANTY.**

Some states do not allow limitations on how long an implied warranty may last, so the above limitations may not apply to you.

You may be required by law to give us a reasonable opportunity to correct or cure any failure to comply before you can bring any action in court against us under the Magnuson-Moss Warranty Act.

### PRODUCT INSTRUCTIONS AND QUESTIONS

Upon purchase or prior to installation, please carefully inspect your Hansgrohe product for any damage or visible defect. Prior to installing, always carefully study the enclosed instructions on the proper installation and the care and maintenance of this product. If you have questions at any time about the use, installation or performance of your Hansgrohe product, or this warranty, please write us or call us toll-free at 800-334-0455.

**hansgrohe**

Hansgrohe, Inc. • 1490 Bluegrass Lakes Parkway • Alpharetta, GA 30004  
Tel. 800-334-0455 • Fax 770-360-9887

[www.hansgrohe-usa.com](http://www.hansgrohe-usa.com)