



FWS1502CP / FWS1502BN
FWS1502ORB

Features

- Lead free brass body
- Ceramic cartridge
- Metal lever handle
- With plastic quick pop up drain
- Waters saving 1.2 gpm max flow rate (4.5 L/min)(ASME A112.18.1M)

Finishes

FWS1502CP	Chrome Finish
FWS1502BN	Brushed Nickel Finish
FWS1502ORB	Oil Rubbed Bronze Finish

Approvals:

Meets or exceeds the following:

- ASME A112.18.1M
- IAPMO/UPC



ADA

Nominal Dimension

Handle opened

- 296L x145D x 146H (mm)

Handle closed

- 152L x 145D x 146H (mm)

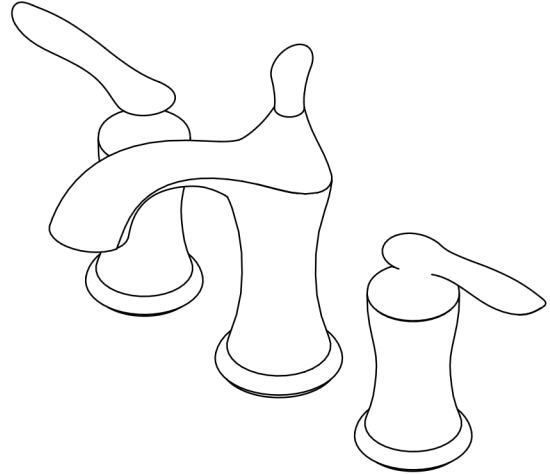

Product Diagrams

Front

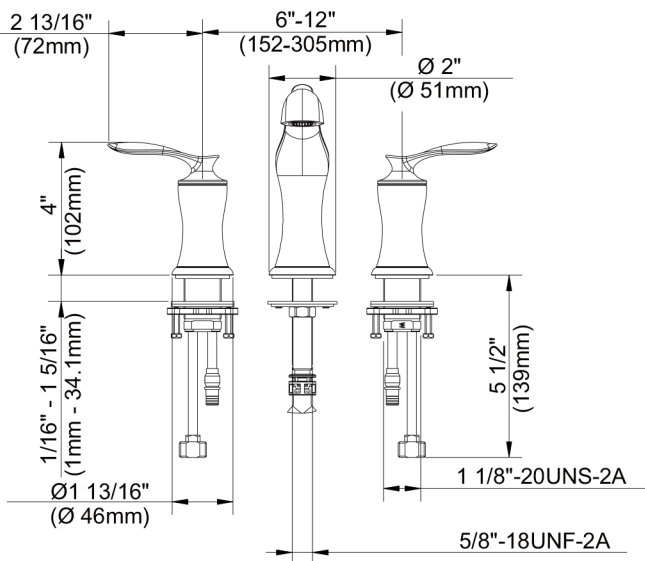

Side

