



Steel Seal™ Washing machine

W5XLW

5-series

Loading capacity: 24.3 lb

1400 rpm

Number of program: 28

ADA Compliant: Yes, standing on the ASKO pedestal drawer

Installation: Freestanding



Programs

- Programmes: Normal cotton, Time program, Mix/synthetic, Wool/hand wash, Jeans, Beddings / Towels, Shirts / Blouses, Down, Waterproofing, Outerwear, Colored laundry, White laundry, Universal wash, Delicates
- Special washing programs: Quick Pro, Steam refresh, Allergy program Synthetics, Allergy program Cotton, SportWash
- Special functions: Drum cleaning, Spin, Drain, Rinse
- Wi-Fi washing programs: Baby clothes, Textile trainers, Soft toys, Underwear, Swimwear
- Modes: Normal - No changes to the program, Green - Saves water and energy. Program time slightly longer, Speed mode - More water and energy used to ensure a clean laundry in shorter time, Intensive mode - Improved cleaning with more water and energy. Temperature is kept at high level for longer

Additional options

- Temperature range: 194 °F
- Spin speed setting: Adjustable
- Max spin speed: 1400 rpm
- Delayed start: Up to 24 hours
- Settings: Prewash, No spin, High water level, Super rinse, Small load option, Steam disinfection, Delayed Start, Add clothes

Construction and performance

- Door sealing: Steel Seal™ - Hygienic sealing without rubber bellow
- Quattro Construction™ : Yes, 2.0 Professional suspension with motorized door lock to minimize noise and vibrations
- Tub: Stainless Steel
- Inner drum: Stainless Steel
- Counter weight material: Cast iron
- Counterweight: 37.5 lb
- Active Drum™ - Ensure a gentle yet effective washing cycle: Yes
- Max +/- 1 °F temperature variation: Yes
- Drum volume: 2.8 Cubic ft
- Door hinge placement: Left
- Door opening diameter: 12 3/16 "
- Door maximum opening angle: 110 °
- Motor: Long life and quiet brushless motor
- Shortest program time: 20 min

Use and flexibility

- Easy Close door: Yes
- Easy door opening: Yes
- Door lock: Motorized
- Stop flap for Liquid detergent: Yes
- Automatic detergent drawer cleaning: Time remaining indicator
- Load Light™ - Illumination of the drum: Yes
- Automatic dosing system: Yes, with detergent and fabric conditioner
- Dose assist: Yes
- Wifi: Yes

- ConnectLife: Monitoring and control in the palm of your hand: ConnectLife
- Bluetooth: Yes
- Included accessory: Discharge hose bow

Interaction and control

- Remaining time indication: Yes
- Type of display: TFT - Full colour touch display (possible to interact with jog dial as well)
- Transparent door cover/Double glass door: No
- Number of program: 28
- Create own program: Yes
- Language settings: Chinese traditional, Chinese simplified, Swedish, Slovenian, Slovak, Russian, Polish, Norwegian, Dutch, Latvian, Lithuanian, Japanese, Italian, Croatian, French, Finnish, Estonian, Spanish, English, German, Danish, Czech, US English, Ukrainian, Serbian, Portuguese, AU English

Design and integration

- Main color of product: White
- Easy mounting of ASKO dryer on top of the washers: Yes
- Loading type: Front load
- Adjustable feet: 3/8 "

Safety and maintenance

- Waterproof bottom plate with leakage detection: Yes
- Maximized water inlet time: Yes
- Aqua safe system: Yes, with bottom sensor
- Water inlet hose: Aqua stop, shuts off water if it leaks
- Drain system: Anti Block™ - Self-cleaning drain pump
- Overflow protection: Yes
- Emergency door opening function: Yes
- Child lock on display: Yes
- Unbalance detection - Protects the washer against harmful vibrations: Yes
- Draining capacity: 5.3 gal/min
- Overheat protection: For motor and electronics

Technical data

- Loading capacity: 24.3 lb
- Plug type: USA
- Connected load: 2200 W
- Voltage (V): 208-240 V
- Number of phases: 1
- Fuse: 15 A
- Frequency: 60 Hz
- Heater power: 2000 W
- Net weight: 216.7 lb
- Water connection: Cold water
- ISO 14001 certified manufacturing: Yes

Dimensions

- Width: 23 7/16 "
- Height: 33 7/16 "
- Depth: 27 1/16 "
- Depth with door open: 44 7/16 "
- Length of electrical cord: 82 11/16 "
- Length inlet hose: 59 1/16 "
- Length outlet hose: 63 "

Logistic information

- Packaging width: 25 1/16 "
- Packaging height: 36 1/4 "
- Packaging depth: 30 9/16 "
- Gross weight: 224.2 lb
- Weight of packaging: 7.5 lb
- Product code: 746441

• EAN code: 3838783003621

Inches (millimetres)

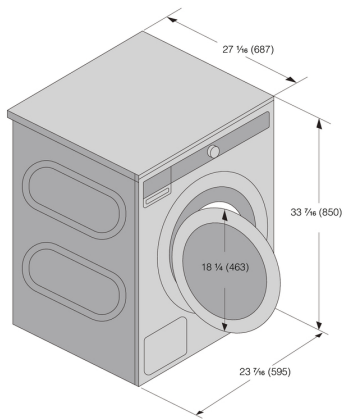

WMD7686 / XL / Cold / USA

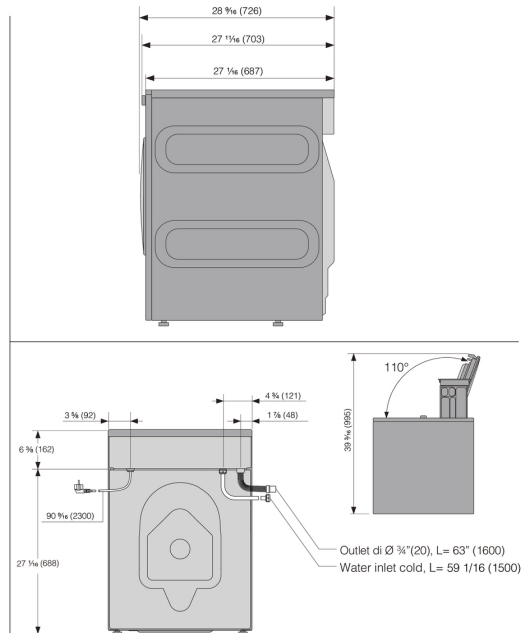



Steel Seal™ Washing machine

W5XLT

5-series

Loading capacity: 24.3 lb

1400 rpm

Number of program: 28

ADA Compliant: Yes, standing on the ASKO pedestal drawer

Installation: Freestanding



Programs

- Programmes: Normal cotton, Time program, Mix/synthetic, Wool/hand wash, Jeans, Waterproofing, Down, Beddings / Towels, Shirts / Blouses, Outerwear, Colored laundry, White laundry, Universal wash, Delicates
- Special washing programs: Quick Pro, Steam refresh, Allergy program Synthetics, Allergy program Cotton, SportWash
- Special functions: Drum cleaning, Spin, Drain, Rinse
- Wi-Fi washing programs: Baby clothes, Textile trainers, Soft toys, Underwear, Swimwear
- Modes: Normal - No changes to the program, Green - Saves water and energy. Program time slightly longer, Speed mode - More water and energy used to ensure a clean laundry in shorter time, Intensive mode - Improved cleaning with more water and energy. Temperature is kept at high level for longer

Additional options

- Temperature range: 194 °F
- Spin speed setting: Adjustable
- Max spin speed: 1400 rpm
- Delayed start: Up to 24 hours
- Settings: Prewash, No spin, High water level, Super rinse, Small load option, Steam disinfection, Add clothes, Pause

Construction and performance

- Door sealing: Steel Seal™ - Hygienic sealing without rubber bellow
- Quattro Construction™ : Yes, 2.0 Professional suspension with motorized door lock to minimize noise and vibrations
- Tub: Stainless Steel
- Inner drum: Stainless Steel
- Counter weight material: Cast iron
- Counterweight: 37.5 lb
- Active Drum™ - Ensure a gentle yet effective washing cycle: Yes
- Max +/- 1 °F temperature variation: Yes
- Drum volume: 2.8 Cubic ft
- Door hinge placement: Left
- Door opening diameter: 12 3/16 "
- Door maximum opening angle: 110 °
- Motor: Long life and quiet brushless motor
- Shortest program time: 20 min

Use and flexibility

- Easy Close door: Yes
- Easy door opening: Yes
- Door lock: Motorized
- Stop flap for Liquid detergent: Yes
- Automatic detergent drawer cleaning: Time remaining indicator
- Load Light™ - Illumination of the drum: Yes
- Automatic dosing system: Yes, with detergent and fabric conditioner
- Dose assist: Yes
- Wifi: Yes

- ConnectLife: Monitoring and control in the palm of your hand: ConnectLife
- Bluetooth: Yes
- Included accessory: Discharge hose bow

Interaction and control

- Remaining time indication: Yes
- Type of display: TFT - Full colour touch display (possible to interact with jog dial as well)
- Transparent door cover/Double glass door: No
- Number of program: 28
- Create own program: Yes
- Language settings: Chinese traditional, Chinese simplified, Swedish, Slovenian, Slovak, Russian, Polish, Norwegian, Dutch, Latvian, Lithuanian, Japanese, Italian, Croatian, French, Finnish, Estonian, Spanish, English, German, Danish, Czech, US English, Ukrainian, Serbian, Portuguese, AU English

Design and integration

- Main color of product: Titanium
- Easy mounting of ASKO dryer on top of the washers: Yes
- Loading type: Front load
- Adjustable feet: 3/8 "

Safety and maintenance

- Waterproof bottom plate with leakage detection: Yes
- Maximized water inlet time: Yes
- Aqua safe system: Yes, with bottom sensor
- Water inlet hose: Aqua stop, shuts off water if it leaks
- Drain system: Anti Block™ - Self-cleaning drain pump
- Overflow protection: Yes
- Emergency door opening function: Yes
- Child lock on display: Yes
- Unbalance detection - Protects the washer against harmful vibrations: Yes
- Draining capacity: 5.3 gal/min
- Overheat protection: For motor and electronics

Technical data

- Loading capacity: 24.3 lb
- Plug type: USA
- Connected load: 2200 W
- Voltage (V): 208-240 V
- Number of phases: 1
- Fuse: 15 A
- Frequency: 60 Hz
- Heater power: 2000 W
- Net weight: 218.3 lb
- Water connection: Cold water
- ISO 14001 certified manufacturing: Yes

Dimensions

- Width: 23 7/16 "
- Height: 33 7/16 "
- Depth: 27 1/16 "
- Depth with door open: 44 7/16 "
- Length of electrical cord: 82 11/16 "
- Length inlet hose: 59 1/16 "
- Length outlet hose: 63 "

Logistic information

- Packaging width: 25 1/16 "
- Packaging height: 36 1/4 "
- Packaging depth: 30 9/16 "
- Gross weight: 225.8 lb
- Weight of packaging: 7.5 lb
- Product code: 746337

• EAN code: 3838783001481

Inches (millimetres)

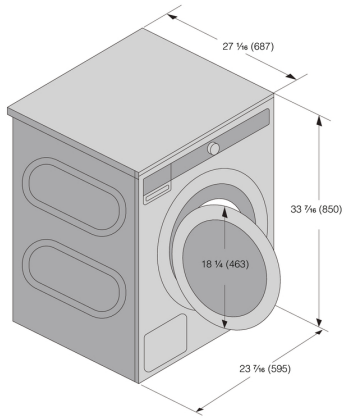

WMD7686 / XL / Cold / USA

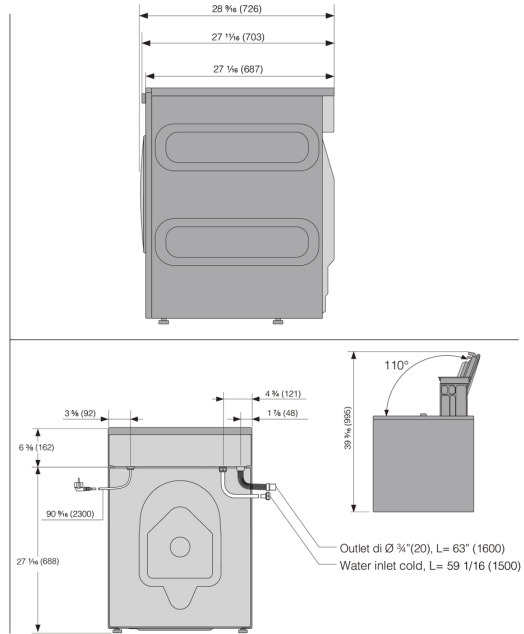



Steel Seal™ Washing machine

W5XLG

5-series

Loading capacity: 24.3 lb

1400 rpm

Number of program: 28

ADA Compliant: Yes, standing on the ASKO pedestal drawer

Installation: Freestanding



Programs

- Programmes: Normal cotton, Time program, Mix/synthetic, Wool/hand wash, Jeans, Beddings / Towels, Shirts / Blouses, Down, Waterproofing, Outerwear, Colored laundry, White laundry, Universal wash, Delicates
- Special washing programs: Quick Pro, Steam refresh, Allergy program Synthetics, Allergy program Cotton, SportWash
- Special functions: Drum cleaning, Spin, Drain, Rinse
- Wi-Fi washing programs: Baby clothes, Textile trainers, Soft toys, Underwear, Swimwear
- Modes: Normal - No changes to the program, Green - Saves water and energy. Program time slightly longer, Speed mode - More water and energy used to ensure a clean laundry in shorter time, Intensive mode - Improved cleaning with more water and energy. Temperature is kept at high level for longer

Additional options

- Temperature range: 194 °F
- Spin speed setting: Adjustable
- Max spin speed: 1400 rpm
- Delayed start: Up to 24 hours
- Settings: Prewash, No spin, High water level, Super rinse, Small load option, Steam disinfection, Delayed Start, Add clothes

Construction and performance

- Door sealing: Steel Seal™ - Hygienic sealing without rubber bellow
- Quattro Construction™ : Yes, 2.0 Professional suspension with motorized door lock to minimize noise and vibrations
- Tub: Stainless Steel
- Inner drum: Stainless Steel
- Counter weight material: Cast iron
- Counterweight: 37.5 lb
- Active Drum™ - Ensure a gentle yet effective washing cycle: Yes
- Max +/- 1 °F temperature variation: Yes
- Drum volume: 2.8 Cubic ft
- Door hinge placement: Left
- Door opening diameter: 12 3/16 "
- Door maximum opening angle: 110 °
- Motor: Long life and quiet brushless motor
- Shortest program time: 20 min

Use and flexibility

- Easy Close door: Yes
- Easy door opening: Yes
- Door lock: Motorized
- Stop flap for Liquid detergent: Yes
- Automatic detergent drawer cleaning: Time remaining indicator
- Load Light™ - Illumination of the drum: Yes
- Automatic dosing system: Yes, with detergent and fabric conditioner
- Dose assist: Yes
- Wifi: Yes

- ConnectLife: Monitoring and control in the palm of your hand: ConnectLife
- Bluetooth: Yes
- Included accessory: Discharge hose bow

Interaction and control

- Remaining time indication: Yes
- Type of display: TFT - Full colour touch display (possible to interact with jog dial as well)
- Transparent door cover/Double glass door: No
- Number of program: 28
- Create own program: Yes
- Language settings: Chinese traditional, Chinese simplified, Swedish, Slovenian, Slovak, Russian, Polish, Norwegian, Dutch, Latvian, Lithuanian, Japanese, Italian, Croatian, French, Finnish, Estonian, Spanish, English, German, Danish, Czech, US English, Ukrainian, Serbian, Portuguese, AU English

Design and integration

- Main color of product: Graphite black
- Easy mounting of ASKO dryer on top of the washers: Yes
- Loading type: Front load
- Adjustable feet: 3/8 "

Safety and maintenance

- Waterproof bottom plate with leakage detection: Yes
- Maximized water inlet time: Yes
- Aqua safe system: Yes, with bottom sensor
- Water inlet hose: Aqua stop, shuts off water if it leaks
- Drain system: Anti Block™ - Self-cleaning drain pump
- Overflow protection: Yes
- Emergency door opening function: Yes
- Child lock on display: Yes
- Unbalance detection - Protects the washer against harmful vibrations: Yes
- Draining capacity: 5.3 gal/min
- Overheat protection: For motor and electronics

Technical data

- Loading capacity: 24.3 lb
- Plug type: USA
- Connected load: 2200 W
- Voltage (V): 208-240 V
- Number of phases: 1
- Fuse: 15 A
- Frequency: 60 Hz
- Heater power: 2000 W
- Net weight: 218.7 lb
- Water connection: Cold water
- ISO 14001 certified manufacturing: Yes

Dimensions

- Width: 23 7/16 "
- Height: 33 7/16 "
- Depth: 27 1/16 "
- Depth with door open: 44 7/16 "
- Length of electrical cord: 82 11/16 "
- Length inlet hose: 59 1/16 "
- Length outlet hose: 63 "

Logistic information

- Packaging width: 25 1/16 "
- Packaging height: 36 1/4 "
- Packaging depth: 30 9/16 "
- Gross weight: 226.2 lb
- Weight of packaging: 7.5 lb
- Product code: 746442

• EAN code: 3838783003638

Inches (millimetres)

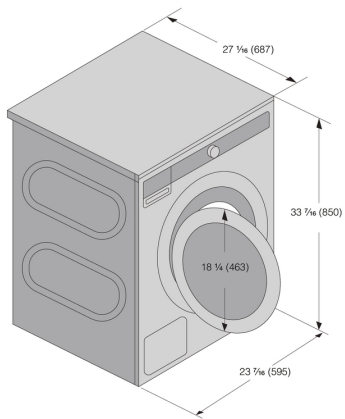

WMD7686 / XL / Cold / USA

