

**ROVAL™ BABY CHANGING STATION – STAINLESS STEEL SURFACE MOUNTED**

Baby Changing Stations

Roval

MasterFormat Section 10 28 13

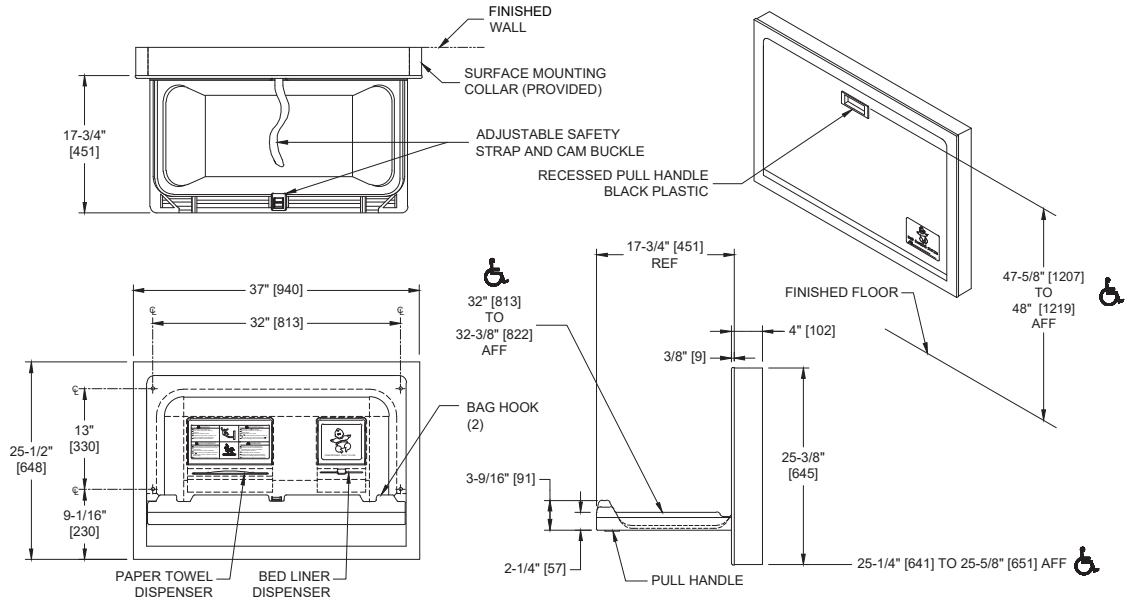

Scan for Information



**SUSTAINABILITY/LEED**

MR 4.1 (1) MR 6 (1) EQ 4.2 (1)  
MR 4.2 (1) EQ 4.1 (1) EQ 4.4 (1)

**NOTE:**  
ALL DIM'S INCH [MM]  
ILLUSTRATION FOR REF ONLY AND NTS

**PRODUCT OVERVIEW**

ADA-compliant unit features welded stainless steel for long and reliable use. Exposed surfaces are satin finish. Easy one-handed operation is assisted by a pull handle and concealed spring. The changing surface is high-impact-resistant plastic for easy cleaning. Its two part adjustable safety strap and 50 lbs (23 kg) load capacity assure child protection. Surface mounted with stainless steel collar.

**KEY FEATURES & SPECIFICATIONS**

- ADA, ASTM F-2285 & F-2388, G-21, G-22, ANSI Z535, ANSI 117.1, EN 1222-1, and EN 1221-2 (Including A1:2013) compliant.
- Includes contoured pull handle, two integral bag hooks and a bed-liner dispenser (convertible to a multi-fold towel dispenser)
- Robust door (16 gauge) and cabinet (18 gauge) are made from Type 304 Stainless Steel - Satin Finish.
- The changing surface is high-impact-resistant plastic for easy cleaning.
- Surface Mounted. Designed to support an infant up to 3 ½ years old and a weight up to 50 lbs (23 kg)
- The bed is designed to cradle a child's body. An adjustable two-part, vinyl-coated safety strap with a Sure-Lock latch aids in safety.
- Unit shall include two bag hooks, bed liner dispenser, and a C-fold towel and multi-fold towel dispenser which can easily be converted to a multi-fold towel dispenser that needs no adapters.

**OPERATION & MAINTENANCE**

Pull down changing table is counterbalanced with a damped gas spring and can be opened or closed with one hand. Unit is operable with less than 5 lbs (22.2N) while not requiring any tight grasping, pinching or twisting of the wrist. Secure the child in place by using child protection safety strap. The safety strap and cam buckle are assembled by sliding the safety strap into the cam buckle until it is snug on child. Tighten or loosen the strap by pulling the strap end through and clamping the buckle. To unbuckle the strap simply lift the buckle lever.

**TECHNICAL INFORMATION / PRODUCT PROPERTIES**

Property	Value
Dimensions	Closed: 37" x 25-1/2" x 4-3/8" [940 x 648 x 111] Open: 37" x 25-1/2" x 21-3/4" [940 x 648 x 552]
Construction	Type 304 Stainless Steel - Satin Finish
Mounting	Surface Mounted
Capacity	Supports an infant up to 3 1/2 years old and a weight up to 50 lbs (23 kg)

**INSTALLATION**

Mount unit to wood studs using four (4) 3/8" x 2" [10 x 51] lag screws provided (or other fasteners appropriate for wall conditions, not supplied) through mounting holes in rear wall of cabinet. Recommended anchor for hollow metal or wood stud walls where studs do not line up with mounting holes is a TOGGLER® model BCS toggle bolt (provided) used with 3/8"-16 screws (provided). For masonry walls use appropriate anchors (not provided). Use washers and snap covers provided. For compliance with 2010 ADA Accessibility Standards install unit so that top edge of changing table is 32" to 32-3/8" [813 to 822] Above Finished Floor (AFF). See installation instructions packed with unit.

**WARRANTY**

Five (5) Years from date of Invoice