

ASSEMBLY INSTRUCTIONS

ITEM DESCRIPTION:

ITEM NO.: DWI07NAME: Brass Sculptural Flush Mount
MATERIAL TYPE: Brass FINISH: Antique Brass _____
SOCKET TYPE: Type A E26 SOCKET QTY: 1 PC
BULB WATTAGE: 60 W VOLATGE: _____
ITEM NET WEIGHT: __3.150 KGS._____

PARTS INCLUDED:

MOUNTING PLATE	QTY: 1	QTY:
BACK PLATE	QTY: 1	QTY:
PLATE SCREW	QTY: 2	QTY:
SOCKET ASSEMBLY	QTY: 1	QTY:
METAL RING	QTY: 1	QTY:
	QTY:	QTY:
	QTY:	QTY:
	QTY:	QTY:

HARDWARE INCLUDED:

Mounting Screws	QTY: 2
Plastic Wire Connectors	QTY: 2
	QTY:

TOOLS NEEDED (NOT INCLUDED):

1 SCREWDRIVER

These instructions are provided for safety. It is very important that they are read carefully and completely before beginning installation of this chandelier.

We strongly suggest that all hard-wired fixtures must be installed by a professional electrician.



TO ASSEMBLE:

1. **Shut off the main electrical supply from the main fuse box/circuit breaker.**
 2. Attach mounting plate to wall or junction box using **mounting screws (C)**.
 3. Connect ground wire from wall to ground wire from lamp using **wire caps (A)**.
 4. Attach house wire to lamp wires as shown. Fasten the pairs together with a **wire cap**.
- DO NOT REVERSE THE HOT AND NEUTRAL CONNECTIONS OR SAFETY WILL BE COMPROMISED.**
5. Attach front face of light to back plate by inserting **canopy screws (B)** through predrilled holes in front face and into back plate as shown. Tighten using screwdriver.
 6. Insert light bulb.
 7. Restore power to junction box and test fixture. **DO NOT EXCEED SPECIFIED MAX WATTAGE.**

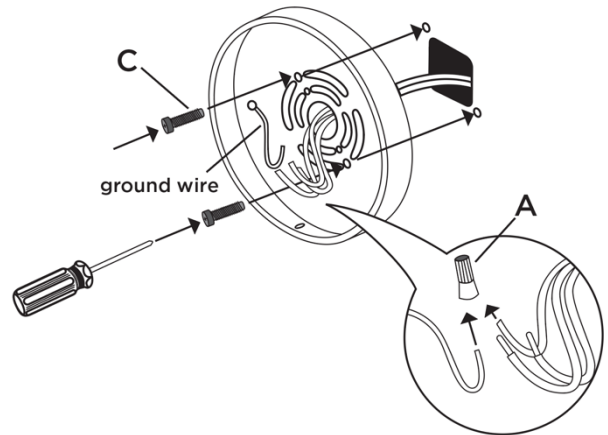

CARE INSTRUCTIONS:

Wipe with a soft, dry cloth. To protect finish, avoid the use of chemicals and household cleaners.

For customer service questions call **1-800-338-2150**
Arteriors Home: **972.488.9800** Arteriors Contract: **972.488.9800 Ext.321**

ARTERIOS

