

ASSEMBLY INSTRUCTIONS

ITEM # DWC09| Oblong Slump Glass Sconce

ITEM DESCRIPTION

MATERIAL TYPE: Metal/Clear Seedy Slump Glass

FINISH:Antique Brass

SOCKET TYPE:E12 CERAMIC

SOCKET QTY: 1PC

BULB TYPE: TYPE B

BULB WATTAGE:25W/6W CFL/2W LED

VOLTAGE: 110V-120V

ITEM NET WEIGHT:

UL COMPLIANT

INSTALLATION ENVIRONMENT:SUITABLE FOR DAMP LOCATIONS



NOTE:

- *YOUR PRODUCT(S) MAY BE PACKED IN MORE THAN ONE CARTON
- *THIS ITEM MAY REQUIRE PERIODIC TIGHTENING

PARTS

A	MOUNTING PLATE	1 PC
B	LAMP BODY	1 PC
C	PLATE SCREW	2 PC
D	GROUND SCREW	1PC
E	COLUMN STOOPER	1 PC
F	GLASS SHADE	1PC

PRODUCT ASSEMBLY

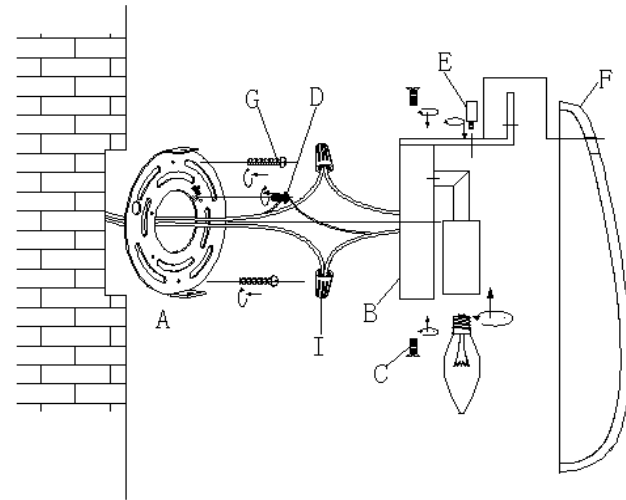

INCLUDED ASSEMBLY HARDWARE

I Plastic wire connectors	G Mounting screw

TOOLS NEEDED(NOT INCLUDED)

J SCREWDRIVER

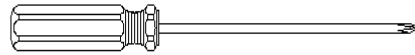

ASSEMBLY INSTRUCTIONS

- 1.REMOVE ALL PACKING CONTENTS AND PARTS FROM THE CARTON(S) CAREFULLY.
- 2.PLEASE BE SURE YOU HAVE ALL PARTS INDICATED BEFORE YOU BEGIN ASSEMBLY.
- 3.TURN OFF POWER TO THE JUNCTION BOX WHERE THE LAMP WILL BE INSTALLED
- 4.REMOVE THE MOUNTING PLATE (A) FROM THE LAMP BODY (B) BY LOOSE PLATE SCREWS(C)
- 5.PULL THE ELECTRICAL CORD OF "J BOX"THROUGH THE EXIT HOLE OF THE MOUNTING PLATE(A)
6. ATTACH THE GROUND WIRE FROM THE FIXTURE TO THE GROUND JUNCTION BOX WIRE FROM THE OUTLET (USUALLY GREEN OR BARE WIRE). FASTEN EACH TOGETHER WITH A PLASTIC WIRE CONNECTOR (I) AND WRAP THE CONNECTION WITH ELECTRICAL TAPE. IF YOUR OUTLET BOX DOES NOT HAVE A GROUND WIRE, INSERT THE GREEN GROUND SCREW(E) INTO THE MOUNTING PLATE (A) FACING DOWN, AND WRAP THE FIXTURE'S BARE GROUND WIRE AROUND THE GROUND SCREW. IT IS IMPERATIVE THAT THE OUTLET BOX IN YOUR HOME BE PROPERLY GROUNDED.
7. CONNECT THE NEUTRAL FIXTURE WIRE TO THE NEUTRAL JUNCTION BOX WIRE (USUALLY WHITE). FASTEN EACH TOGETHER WITH A WIRE CONNECTOR (I) AND WRAP THE CONNECTION WITH ELECTRICAL TAPE. BE SURE NO STRANDS ARE EXPOSED.
- 8.CONNECT THE HOT FIXTURE WIRE TO THE HOT JUNCTION BOX WIRE (USUALLY BLACK). FASTEN EACH TOGETHER WITH A PLASTIC WIRE CONNECTOR (I) AND WRAP THE CONNECTION WITH ELECTRICAL TAPE. BE SURE NO WIRE STRANDS ARE EXPOSED. DO NOT REVERSE THE HOT AND NEUTRAL CONNECTIONS OR SAFETY WILL BE COMPROMISED.
- 9.GENTLY TUCK THE WIRE CONNECTIONS NEATLY INTO THE CEILING JUNCTION BOX.
- 10.ATTACH THE MOUNTING PLATE (A) TO THE OUTLET BOX USING THE MOUNTING SCREWS(D).TIGHTEN WITH A SCREWDRIVER(NOT INCLUDED (J)
- 11.ATTACH THE BACK PLATE(B) TO THE MOUNTING PLATE(A) USING THE ENCLOSED PLATE SCREWS(C). TIGHTEN SCREWS WITH A SCREWDRIVER (NOT INCLUDED (J)).
- 12.INSTALLT TYPE B 25W BULB (OR 6W CFL/2W LED,NOT INCLUDED)INTO THREADED SOCKET.
- 13.PLEASE INSTALL THE GLASS SHADE ONTO HANGER PROPERLY AS ILLUSTRATION,THEN SECURE IT WITH COLUMN STOPPER.

CARE & MAINTENANCE

DUST WITH A DRY CLOTH.

DISCLAIMERS

FOR CUSTOMER SERVICE QUESTIONS CALL 1.888.488.8866

WE RECOMMEND THE INSTALLATION OF THIS ELECTRICAL LIGHT FIXTURE TO BE DONE BY A LICENSED ELECTRICIAN.

ARTERIORS HOME:972.488.9800

ARTERIORS CONTRACT:972.488.9800 EXT.321

ARTERIORS