

ASSEMBLY INSTRUCTIONS

ITEM #DWC08| PICTURE LIGHT SCONCE

ITEM DESCRIPTION

MATERIAL TYPE: STEEL, GLASS FINISH: ANTIQUE BRASS + OPAL + ENGLISH BRONZE TOP COAT/SEALANT:
 SOCKET TYPE: E12 CERAMIC SOCKET QTY: 1PC
 BULB TYPE: TYPE T BULB WATTAGE: 40W or /CFL 9W or /LED 4W VOLTAGE: 110V-120V
 ITEM NET WEIGHT: 2.40KGS
 UL COMPLIANT
 INSTALLATION ENVIRONMENT: SUITABLE FOR DAMP LOCATIONS



NOTE:
 *YOUR PRODUCT(S) MAY BE PACKED IN MORE THAN ONE CARTON
 *THIS ITEM MAY REQUIRE PERIODIC TIGHTENING

PARTS

A	MOUNTING PLATE	1 PC
B	SET SCREW	4 PCS
C	LAMP BASE	1 PC
D	THREADED POST	1 PC
E	METAL GLASS CAP	1 PC
F	BULB (NOT INCLUDED)	1 PC
G	SOCKET	1 PC
H	METAL GLASS COVER	1 PC
I	GLASS SHADE	1 PC

INCLUDED ASSEMBLY HARDWARE

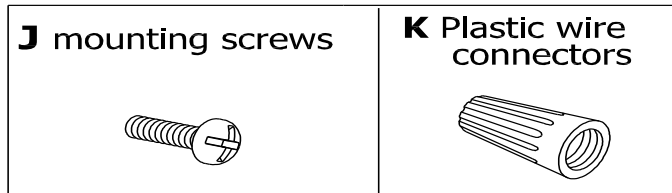

PRODUCT ASSEMBLY

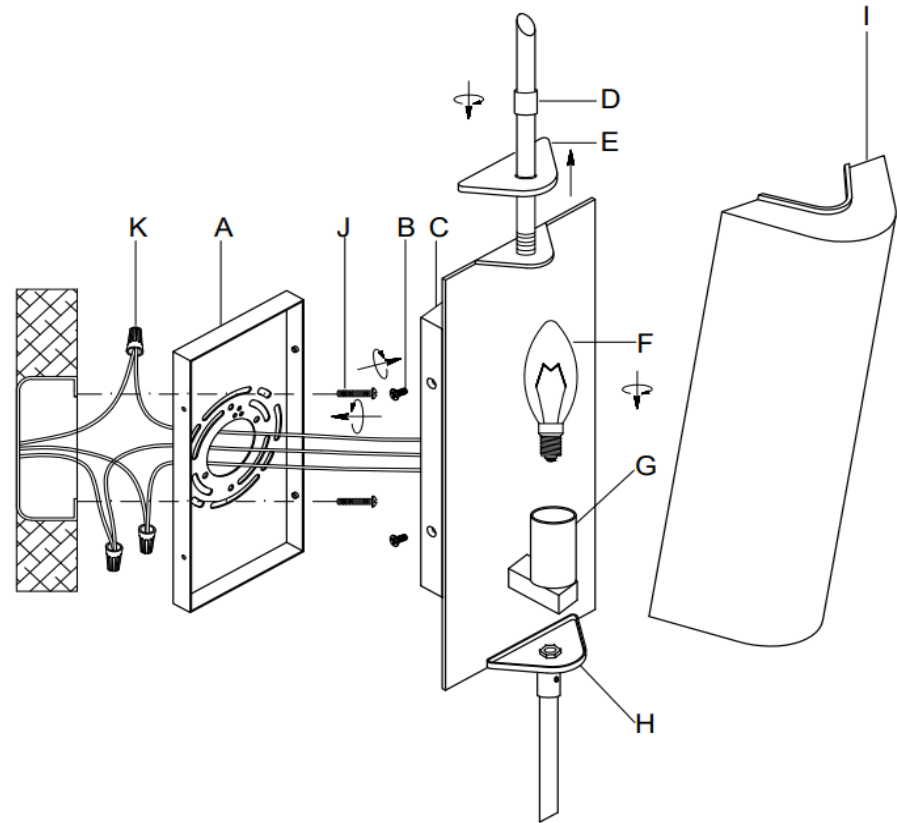

ASSEMBLY INSTRUCTIONS

1. REMOVE ALL PACKING CONTENTS AND PARTS FROM THE CARTON(S) CAREFULLY
2. PLEASE BE SURE YOU HAVE ALL PARTS INDICATED BEFORE YOU BEGIN ASSEMBLY
3. SHUT OFF THE MAIN ELECTRICAL SUPPLY FROM THE MAIN FUSE BOX/CIRCUIT BREAKER.
4. PULL THE ELECTRICAL CORD OF "J BOX" THROUGH THE EXIT HOLE OF THE MOUNTING PLATE (A)
5. CAREFULLY INSPECT THE FIXTURE WIRES. THE NEUTRAL FIXTURE WIRE HAS VERY FINE RIDGES MOLDED INTO ITS PLASTIC COVERING. THE HOT FIXTURE WIRE HAS A SMOOTH COVERING. THE BARE WIRE IS THE GROUNDED WIRE.
6. ATTACH THE GROUND WIRE FROM THE FIXTURE TO THE GROUND JUNCTION BOX WIRE FROM THE OUTLET (USUALLY GREEN OR BARE WIRE). FASTEN EACH TOGETHER WITH A PLASTIC WIRE CONNECTOR (K) AND WRAP THE CONNECTION WITH ELECTRICAL TAPE. IF YOUR OUTLET BOX DOES NOT HAVE A GROUND WIRE, INSERT THE GREEN GROUND SCREW INTO THE MOUNTING PLATE (A) FACING DOWN, AND WRAP THE FIXTURE'S BARE GROUND WIRE AROUND THE GROUND SCREW. **IT IS IMPERATIVE THAT THE OUTLET BOX IN YOUR HOME BE PROPERLY GROUNDED.**
7. CONNECT THE NEUTRAL FIXTURE WIRE TO THE NEUTRAL JUNCTION BOX WIRE (USUALLY WHITE). FASTEN EACH TOGETHER WITH A WIRE CONNECTOR (K) AND WRAP THE CONNECTION WITH ELECTRICAL TAPE. BE SURE NO STRANDS ARE EXPOSED.
8. CONNECT THE HOT FIXTURE WIRE TO THE HOT JUNCTION BOX WIRE (USUALLY BLACK). FASTEN EACH TOGETHER WITH A PLASTIC WIRE CONNECTOR (K) AND WRAP THE CONNECTION WITH ELECTRICAL TAPE. BE SURE NO WIRE STRANDS ARE EXPOSED. **DO NOT REVERSE THE HOT AND NEUTRAL CONNECTIONS OR SAFETY WILL BE COMPROMISED.**
9. GENTLY TUCK THE WIRE CONNECTIONS NEATLY INTO THE JUNCTION BOX.
10. ATTACH THE MOUNTING PLATE (A) TO THE OUTLET BOX BY USING THE MOUNTING SCREWS (J) AND TIGHTEN SCREWS WITH A SCREWDRIVER.
11. ATTACH THE LAMP BASE (C) TO THE MOUNTING PLATE (A) BY USING THE ENCLOSED SET SCREWS (B) AND SECURE THE LAMP BASE (C) BY TIGHTENING 4 SET SCREWS (B) IN A CLOCKWISE DIRECTION.
12. INSERT 1 TYPE T 40W or /CFL 9W or /LED 4W BULB (NOT INCLUDED) INTO THE SOCKET (G). **DO NOT EXCEED SPECIFIED WATTAGE.**
13. WHEN YOU FIX THE GLASS SHADE, LOOSEN THE THREADED POST (D) FIRST IN A COUNTERCLOCKWISE DIRECTION
14. CAREFULLY TO PUT THE GLASS SHADE (I) ONTO THE LAMP BASE (C) AND BE SURE GLASS BOTTOM TO FIT THE METAL GLASS COVER (H) FIRST, **THEN PLACE** THE METAL GLASS CAP (E) TO COVER THE TOP OF THE GLASS SHADE (I), THEN **GENTLY** TIGHTEN THE THREADED POST (D) IN A CLOCKWISE DIRECTION TO SECURE THE GLASS SHADE.
15. RESTORE POWER TO THE JUNCTION BOX AND TEST FIXTURE.

CARE & MAINTENANCE

DUST WITH A DRY CLOTH.

FOR CUSTOMER SERVICE QUESTIONS CALL 1.888.488.8866

ARTERIORES HOME: 972.488.9800

ARTERIORES CONTRACT: 972.488.9800 EXT. 321

DISCLAIMERS

WE RECOMMEND THE INSTALLATION OF THIS ELECTRICAL LIGHT FIXTURE TO BE DONE BY A LICENSED ELECTRICIAN.

ARTERIORES