

ASSEMBLY INSTRUCTIONS

ITEM # DPC02 Alabaster Accent With Hex Shade Pendant

ITEM DESCRIPTION

MATERIAL TYPE: Metal / Alabaster Marble FINISH : Antique Brass / Alabaster Marble
 SOCKET TYPE: E26 CERAMIC SOCKET QTY:1PC TOP COAT/SEALANT: YES
 BULB TYPE: TYPE A BULB WATTAGE: 60W/13W CFL/5W LED VOLTAGE:110V-120V
 ITEM NET WEIGHT:3 KGS TOP COAT/SEALANT:

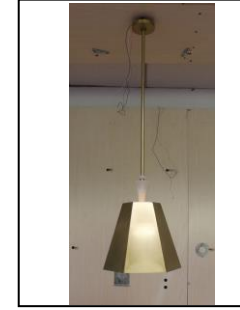

UL COMPLIANT

INSTALLATION ENVIRONMENT: SUITABLE FOR DAMP LOCATIONS

NOTE:
 *YOUR PRODUCT(S) MAY BE PACKED IN MORE THAN ONE CARTON
 *THIS ITEM MAY REQUIRE PERIODIC TIGHTENING

PARTS

A	MOUNTING PLATE	1PC
B	CANOPY	1PC
C	COLLAR LOOP	1PC
D	RODS	4PC
E	ASSEMBLY PART	1PC
F	SOCKET RING	1PC
G	METAL SHADE	1PC

INCLUDED ASSEMBLY HARDWARE

H Plastic wire connectors



I mounting screws



J allen wrench



PRODUCT ASSEMBLY

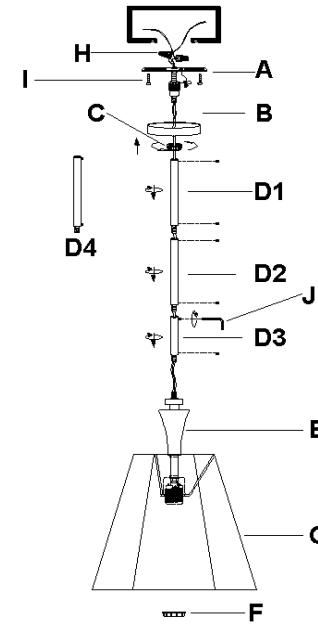

ASSEMBLY INSTRUCTIONS

- 1.REMOVE ALL PACKING CONTENTS FROM THE CARTON CAREFULLY
- 2.REMOVE ALL PARTS FROM THE PACKAGE(S) CAREFULLY
- 3.PLEASE BE SURE YOU HAVE ALL PARTS INDICATED BEFORE YOU BEGIN ASSEMBLY
- 4.SHUT OFF THE MAIN ELECTRICAL SUPPLY FROM THE MAIN FUSE BOX/CIRCUIT BREAKER
- 5.REMOVE THE MOUNTING PLATE(A)FROM THE CANOPY(B)BY TURNING COLLAR LOOP(C) IN A COUNTER CLOCKWISE DIRECTION.
- 6.SCREW THE ROD(D3) TO THE TOP ASSEMBLY PART(E) AND TIGHTEN HEXANGULAR SCREW IN THE SIDE DESIRE HOLE BY ALLEN WRENCH(J) . REPEAT THE SAME OPERATION ON THE ROD (D1)AND (D2).F THE CEILING IS HIGH ENOUGH , PLS ASSEMBLE THE ROD(D4)IF NEED.
- 7.INSTALL 1PCS TYPE A 60W BULB(OR SUITABLE CFL/13W,OR LED 5W NOT INCLUDED) INTO THE SOCKET.
DO NOT EXCEED SPECIFIED WATTAGE.
- 8.CAREFULLY INSPECT THE PENDANT'S FIXTURE WIRES. THE NEUTRAL FIXTURE WIRE HAS VERY FINE RIDEGS MOLDED INTO ITS PLASTIC COVERING. THE HOT FIXTURE WIRE HAS A SMOOTH COVERING.THE BARE SILVER WIRE IS THE GROUNDED WIRE.
- 9.ATTACH THE GROUND WIRE FROM THE FIXTURE TO THE GROUND JUNCTION BOX WIRE FROM THE OUTLET (USUALLY GREEN) OR BARE WIRE). FASTEN EACH TOGETHER WITH A PLASTIC WIRE CONNECTOR (H) AND WRAP THE CONNECTION WITH ELECTRICAL TAPE. IF YOUR OUTLET BOX DOES NOT HAVE A GROUND WIRE, INSERT THE GREEN GROUND SCREW INTO THE MOUNTING PLATE (A) FACING DOWN, AND WRAP THE FIXTURE'S BARE GROUND WIRE AROUND THE GROUND SCREW. IT IS IMPERATIVE THAT THE OUTLET BOX IN YOUR HOME BE PROPERLY GROUNDED.
10. CONNECT THE NEUTRAL FIXTURE WIRE TO THE NEUTRAL JUNCTION BOX WIRE (USUALLY WHITE). FASTEN EACH TOGETHER WITH A WIRE CONNECTOR (H) AND WRAP THE CONNECTION WITH ELECTRICAL TAPE. BE SURE NO STRANDS ARE EXPOSED.
- 11CONNECT THE HOT FIXTURE WIRE TO THE HOT JUNCTION BOX WIRE (USUALLY BLACK). FASTEN EACH TOGETHER WITH A PLASTIC WIRE CONNECTOR (H) AND WRAP THE CONNECTION WITH ELECTRICAL TAPE. BE SURE NO WIRE STRANDS ARE EXPOSED. DO NOT REVERSE THE HOT AND NEUTRAL CONNECTIONS OR SAFETY WILL BE COMPROMISED
12. GENTLY TUCK THE WIRE CONNECTIONS NEATLY INTO THE CEILING JUNCTION BOX
- 13.ATTACH THE MOUNTING PLATE (A) WITH NIPPLE TO THE CEILING OUTLET BOX USING THE ENCLOSED MOUNTING SCREWS (I) AND TIGHTEN SCREWS WITH A SCREWDRIVER.
14. PUSH COLLAR LOOP IN CANOPY (B) AND THREAD ONTO NIPPLE IN MOUNTING PLATE (A) BY TURNING IN A CLOCKWISE
- 15.SCREW ROD (D1) TO CANOPY (B), USING HEXANGULAR SCREW AND ALLEN WRENCH(J)
BE SURE ALL THE HEXANGULAR SCREWS ARE TIGHT ENOUGH.
- 16.PLACE THE METAL SHADE(G) ONTO SOCKET AND SECURE IT WITH SOCKET RING(F)

CARE & MAINTENANCE

FOR CUSTOMER SERVICE QUESTION CALL 1.800.338 **DISCLAIMERS**

ARTERIOS HOME:972.488.9800

ARTERIOS CONTRACT:972.488.9800 EXT.321

WE RECOMMEND THE INSTALLATION OF THIS ELECTRICAL LIGHT FIXTURE TO BE DONE BY A LICENSED ELECTRICIAN.

ARTERIOS