

# ASSEMBLY INSTRUCTIONS

## ITEM DESCRIPTION

MATERIAL TYPE: STEEL,ONYX FINISH :ANTIQUE BRASS,WHITE ONYX  
SOCKET TYPE:LED2700K ,CRI 90 SOCKET QTY: 1PC  
BULB TYPE: BULB WATTAGE: LED 36W VOLTAGE:100V-130V  
ITEM NET WEIGHT:  
UL COMPLIANT  
INSTALLATION ENVIRONMENT:SUITABLE FOR DAMP LOCATIONS

### NOTE:

\*YOUR PRODUCT(S) MAY BE PACKED IN MORE THAN ONE CARTON  
\*THIS ITEM MAY REQUIRE PERIODIC TIGHTENING

## PARTS

<b>A</b>	MOUNTING PLATE	1 PC
<b>B</b>	CANOPY	1 PC
<b>C</b>	COLLAR LOOP	1 PC
<b>D1,2,3,4</b>	RODS	4PCS
<b>E</b>	SET SCREW	9PCS
<b>I</b>	LAMP BODY	1 PC
<b>L</b>	WHITE ONYX	6 PCS
<b>T</b>	2-WIRE TERMINAL	1 PC

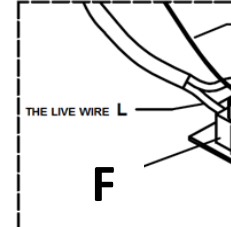

**PLEASE IGNORE THIS DEVICE IN THE**

## INCLUDED ASSEMBLY HARDWARE TOOLS NEEDED(INCLUDED)

**J** mounting screws



**K** Plastic wire connectors

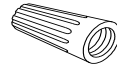

**U** Allen wrench



## ASSEMBLY INSTRUCTIONS

- 1.REMOVE ALL PACKING CONTENTS AND PARTS FROM THE CARTON(S) CAREFULLY.
- 2.PLEASE BE SURE YOU HAVE ALL PARTS INDICATED BEFORE YOU BEGIN ASSEMBLY
- 3.SHUT OFF THE MAIN ELECTRICAL SUPPLY FROM THE MAIN FUSE BOX/CIRCUIT BREAKER
- 4.PASS THE WIRES THROUGH CORDS(D1,D2,D3) THEN CONNECT LAMP BODY(F) AND CANOPY(B) WITH ROD(D1,D2,D3), WHEN YOU CONNECT THE RODS, LOOSEN THE SET SCREWS(E) FIRST THEN TIGHTEN WITH ALLEN WRENCH(U) AFTER ALL RODS. BE SURE ALL THE SET SCREWS ARE TIGHT ENOUGH.
- NOTE: IF YOU WANT THE FIXTURE TO BE SEMI-FLUSH MOUNT, YOU HAVE TO DISCONNECT THE LAMP BODY WIRES FROM THE 2-WIRE TERMINAL(T), AND CONNECT LAMP BODY AND CANOPY(B) WITH ROD (D4). THEN CONNECT THE LAMP BODY WIRE AND DEVICE TO THE 2-WIRE TERMINAL(T).**
- 5.REMOVE THE MOUNTING PLATE(A) FROM THE CANOPY(B) BY TURNING COLLAR LOOP(C)
- 6.PULL THE ELECTRICAL CORD OF "J BOX" THROUGH THE EXIT HOLE OF THE MOUNTING PLATE
- 7.PLEASE PAY SPECIAL ATTENTION THAT YOU DO NOT NEED TO CONNECT THE TERMINAL (T) **IT IS USED FOR THE WIRE CONNECTION FOR EURO-MARKET.**
- 8.CAREFULLY INSPECT THE FIXTURE WIRES. THE NEUTRAL FIXTURE WIRE HAS VERY THIN INSULATION. THE HOT FIXTURE WIRE HAS A SMOOTH COVERING. THE BARE SILVER WIRE IS THE NEUTRAL WIRE AND THE BARE GREEN WIRE IS THE GROUND WIRE.
- 9.ATTACH THE GROUND WIRE FROM THE FIXTURE TO THE GROUND JUNCTION BOX WIRE WITH A PLASTIC WIRE CONNECTOR (K) AND WRAP THE CONNECTION WITH ELECTRICAL TAPE. IF THE JUNCTION BOX DOES NOT HAVE A GROUND WIRE, INSERT THE GREEN GROUND SCREW INTO THE FIXTURE'S BARE GROUND WIRE AROUND THE GROUND SCREW. IT IS IMPERATIVE TO CONNECT THE GROUND WIRE TO THE GROUND SCREW.
- 10.CONNECT THE NEUTRAL FIXTURE WIRE TO THE NEUTRAL JUNCTION BOX WIRE (USUALLY BLUE) WITH A WIRE CONNECTOR (K) AND WRAP THE CONNECTION WITH ELECTRICAL TAPE.
- 11.CONNECT THE HOT FIXTURE WIRE TO THE HOT JUNCTION BOX WIRE (USUALLY BLACK) WITH A PLASTIC WIRE CONNECTOR (K) AND WRAP THE CONNECTION WITH ELECTRICAL TAPE. **DO NOT REVERSE THE HOT AND NEUTRAL CONNECTIONS OR SAFETY WILL BE COMPROMISED.**
12. GENTLY TUCK THE WIRE CONNECTIONS(K) NEATLY INTO THE CEILING JUNCTION BOX
- 13.ATTACH THE MOUNTING PLATE (A) WITH NIPPLE TO THE CEILING OUTLET BOX USING THE SET SCREWS(J) WITH A SCREWDRIVER.
- 14.PUSH COLLAR LOOP(C) IN CANOPY (B) AND TIGHTEN ONTO NIPPLE IN MOUNTING PLATE (A)
- 15.PUT THE 6PCS WHITE ONYX (L) TO THE LAMP BODY(I).
- 16.RESTORE POWER TO THE JUNCTION BOX AND TEST FIXTURE.

## CARE & MAINTENANCE

WIPED WITH A DRY CLOTH.

FOR CUSTOMER SERVICE QUESTIONS CALL 1.888.488.8866

ARTERIOS HOME:972.488.9800

ARTERIOS CONTRACT:972.488.9800 EXT.321

**DISCLAIMER**

WE RECOMMEND

# ARTERIC

TOP COAT/SEALANT:



**PRODUCT ASSEMBLY**



**BE CAREFUL TO MAKE SURE THIS WIRE IS CONNECTED TO THE CANOPY**

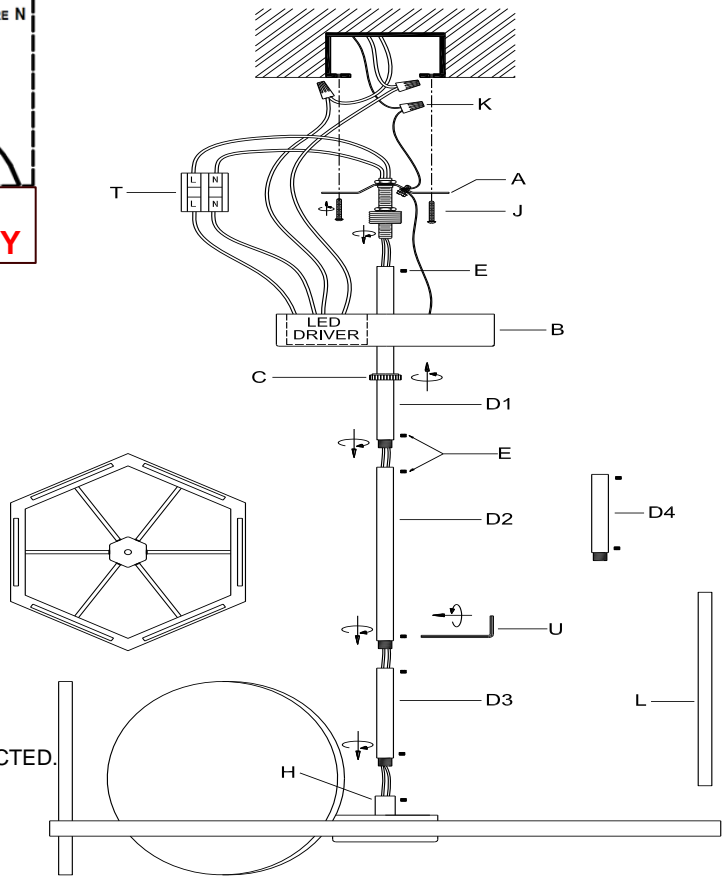

1. ASSEMBLY

2. ALL WIRE CONNECTIONS ARE CONNECTED.

3. CONNECT THE LED DRIVER (H)

4. CONNECT THE WIRES BY 2-WIRE TERMINAL(T).

5. TURN THE LED DRIVER (C) IN A COUNTER CLOCKWISE DIRECTION.

6. REMOVE THE MOUNTING PLATE

7. REMOVE THE TERMINAL BLOCK(F).

8. REMOVE THE FINE RIDGES MOLDED INTO ITS PLASTIC COVERING.

9. REMOVE THE GROUNDED WIRE.

10. REMOVE THE WIRE FROM THE OUTLET (USUALLY GREEN OR BARE WIRE).

11. MAKE THE CONNECTION WITH ELECTRICAL TAPE. IF YOUR OUTLET BOX

12. IS NOT GROUNDING THE MOUNTING PLATE (A) FACING DOWN, AND WRAP THE

13. TAPE THAT THE OUTLET BOX IN YOUR HOME BE PROPERLY GROUNDED.

14. REMOVE THE NEUTRAL WIRE (USUALLY WHITE). FASTEN EACH TOGETHER

15. WITH ELECTRICAL TAPE. BE SURE NO STRANDS ARE EXPOSED.

16. REMOVE THE GROUND WIRE (USUALLY GREEN OR BARE WIRE). FASTEN EACH TOGETHER

17. WITH ELECTRICAL TAPE. BE SURE NO WIRE STRANDS

18. ARE EXPOSED. SAFETY WILL BE COMPROMISED.

19. REMOVE THE OUTLET BOX.

20. REMOVE THE WIRE FROM THE OUTLET (USUALLY GREEN OR BARE WIRE). FASTEN EACH TOGETHER WITH ELECTRICAL TAPE. BE SURE NO WIRE STRANDS ARE EXPOSED. SAFETY WILL BE COMPROMISED.

21. REMOVE THE MOUNTING PLATE (A) BY TURNING IN A CLOCKWISE.

**DISCLAIMERS**

THE INSTALLATION OF THIS ELECTRICAL LIGHT FIXTURE TO BE DONE BY A LICENSED ELECTRICIAN.