

# ASSEMBLY INSTRUCTIONS

ITEM# DFC04 | TOREN FLUSH MOUNT

## ITEM DESCRIPTION

MATERIAL TYPE: METAL+ALABASTER FINISH: EBN + ALABASTER TOP COAT/SEALANT  
 SOCKET TYPE: E26 CERAMIC SOCKET QTY: 1PCS  
 BULB TYPE: TYPE G BULB WATTAGE: 60W or/CFL 12W or/LED 10W VOLTAGE: 110V-120V  
 ITEM NET WEIGHT:  
 UL COMPLIANT  
 INSTALLATION ENVIRONMENT: SUITABLE FOR DAMP LOCATIONS



### NOTE:

- \*YOUR PRODUCT(S) MAY BE PACKED IN MORE THAN ONE CARTON
- \*THIS ITEM MAY REQUIRE PERIODIC TIGHTENING
- \*MIN 90°C SUPPLY CONDUCTORS

## PARTS

A	MOUNTING PLATE	1 PC
B	LAMP BODY	1 PC
C	THUMB SCREW	8 PC
D	SOCKET	1PCS
E	BULB(NOT INCLUDED)	1PCS
F	ALABASTER SHADE	1PCS

## PRODUCT ASSEMBLY

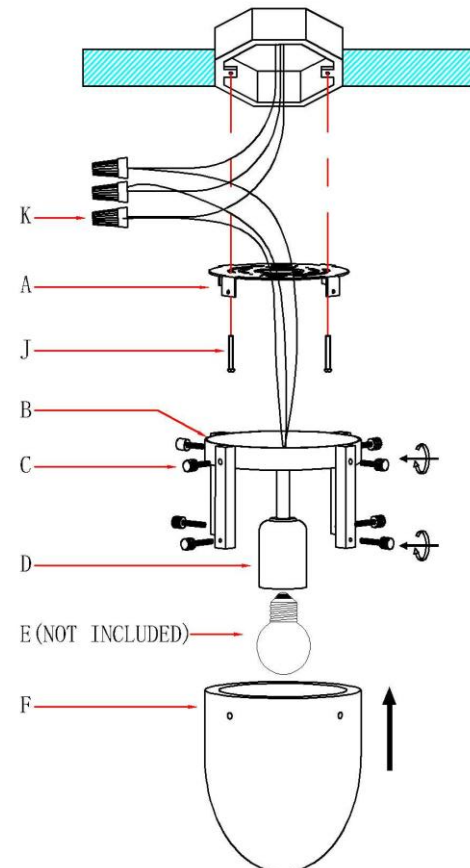

## INCLUDED ASSEMBLY HARDWARE

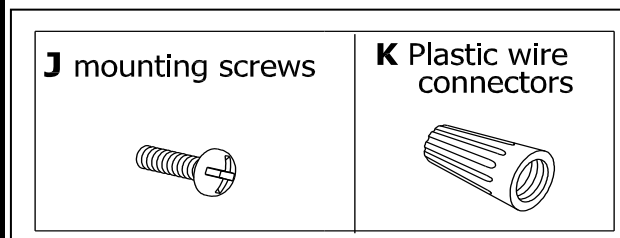

## ASSEMBLY INSTRUCTIONS

1. REMOVE ALL PACKING CONTENTS AND PARTS FROM THE CARTON(S) CAREFULLY.
2. PLEASE BE SURE YOU HAVE ALL PARTS INDICATED BEFORE YOU BEGIN ASSEMBLY.
3. SHUT OFF THE MAIN ELECTRICAL SUPPLY FROM THE MAIN FUSE BOX/CIRCUIT BREAKER.
4. REMOVE THE MOUNTING PLATE (A) FROM THE LAMP BODY (B) BY REMOVING 4PCS THUMB SCREWS (C).
5. PULL THE ELECTRICAL CORD OF "J BOX" THROUGH THE EXIT HOLE OF THE MOUNTING PLATE (A).
6. CAREFULLY INSPECT THE FIXTURE WIRES. THE NEUTRAL FIXTURE WIRE HAS VERY FINE RIDGES MOLDED INTO ITS PLASTIC COVERING. THE HOT FIXTURE WIRE HAS A SMOOTH COVERING. THE BARE WIRE IS THE GROUNDED WIRE.
7. ATTACH THE GROUND WIRE FROM THE FIXTURE TO THE GROUND JUNCTION BOX WIRE FROM THE OUTLET (USUALLY GREEN OR BARE WIRE). FASTEN EACH TOGETHER WITH A PLASTIC WIRE CONNECTOR (K) AND WRAP THE CONNECTION WITH ELECTRICAL TAPE. IF YOUR OUTLET BOX DOES NOT HAVE A GROUND WIRE, INSERT THE GREEN GROUND SCREW INTO THE MOUNTING PLATE (A) FACING DOWN, AND WRAP THE FIXTURE'S BARE GROUND WIRE AROUND THE GROUND SCREW. **IT IS IMPERATIVE THAT THE OUTLET BOX IN YOUR HOME BE PROPERLY GROUNDED.**
8. CONNECT THE NEUTRAL FIXTURE WIRE TO THE NEUTRAL JUNCTION BOX WIRE (USUALLY WHITE). FASTEN EACH TOGETHER WITH A WIRE CONNECTOR (K) AND WRAP THE CONNECTION WITH ELECTRICAL TAPE. BE SURE NO STRANDS ARE EXPOSED.
9. CONNECT THE HOT FIXTURE WIRE TO THE HOT JUNCTION BOX WIRE (USUALLY BLACK). FASTEN EACH TOGETHER WITH A PLASTIC WIRE CONNECTOR (K) AND WRAP THE CONNECTION WITH ELECTRICAL TAPE. BE SURE NO WIRE STRANDS ARE EXPOSED.
- DO NOT REVERSE THE HOT AND NEUTRAL CONNECTIONS OR SAFETY WILL BE COMPROMISED.**
10. GENTLY TUCK THE WIRE CONNECTIONS (K) NEATLY INTO THE CEILING JUNCTION BOX.
11. ATTACH THE MOUNTING PLATE (A) TO THE CEILING OUTLET BOX USING THE ENCLOSED MOUNTING SCREWS (J) AND TIGHTEN SCREWS (J) WITH A SCREWDRIVER.
12. ATTACHED THE LAMP BODY (B) TO THE MOUNTING PLATE (A) AND FASTEN IT WITH 4PCS THUMB SCREW (C) BY TURNING IN A CLOCKWISE DIRECTION.
13. INSERT 1 TYPE G 60W BULBS (OR /CFL 12W OR /LED 10W, NOT INCLUDED) INTO THE SOCKET (D). **DO NOT EXCEED THE SPECIFIED WATTAGE.**
14. PUT THE ALABASTER SHADE (F) ON LAMP BODY (B) THEN TIGHTEN THE SET SCREW (C) IN CLOCKWISE DIRECTION TO LAMP BODY (B).
15. RESTORE POWER TO THE JUNCTION BOX AND TEST FIXTURE.

## CARE & MAINTENANCE

DUST WITH A DRY CLOTH.

FOR CUSTOMER SERVICE QUESTIONS CALL 1.888.488.8866

ARTERIOS HOME: 972.488.9800

ARTERIOS CONTRACT: 972.488.9800 EXT.321

## DISCLAIMERS

WE RECOMMEND THE INSTALLATION OF THIS ELECTRICAL LIGHT FIXTURE TO BE DONE BY A LICENSED ELECTRICIAN.

# ARTERIOS