

ASSEMBLY INSTRUCTIONS

ITEM #89654 | VERTICAL PILLOWED CHANDELIER

ITEM DESCRIPTION

MATERIAL TYPE: STEEL, GLASS FINISH: ANTIQUE BRASS, SMOKE LUSTER GLASS, CLEAR SEEDY GLASS TOP COAT/SEALANT
 SOCKET TYPE: E12 CERAMIC SOCKET QTY: 5PCS
 BULB TYPE: TYPE G BULB WATTAGE: **40W or/CFL 9W or/LED 4W** VOLTAGE: 110V-120V
 ITEM NET WEIGHT: 7.15KGS
 UL COMPLIANT
 INSTALLATION ENVIRONMENT: SUITABLE FOR **DAMP** LOCATIONS



NOTE:

*YOUR PRODUCT(S) MAY BE PACKED IN MORE THAN ONE CARTON
 *THIS ITEM MAY REQUIRE PERIODIC TIGHTENING

PARTS

A	MOUNTING PLATE	1 PC
B	CANOPY	1 PC
C	COLLAR LOOP	1 PC
D1, D2, D3, D4	ROD	4 PCS
E	HEX SCREW	9 PCS
F	LAMP BODY	1 PC
G	SOCKET	5 PCS
H	OVAL GLASS SHADE	5 PCS
I	DECORATIVE RING	5 PCS
N	BULB(not included bulb)	5 PCS
M	ROUND GLASS SHADE	5 PCS

INCLUDED ASSEMBLY HARDWARE

J MOUNTING SCREWS	K PLASTIC WIRE CONNECTORS
L ALLEN WRENCH	

PRODUCT ASSEMBLY

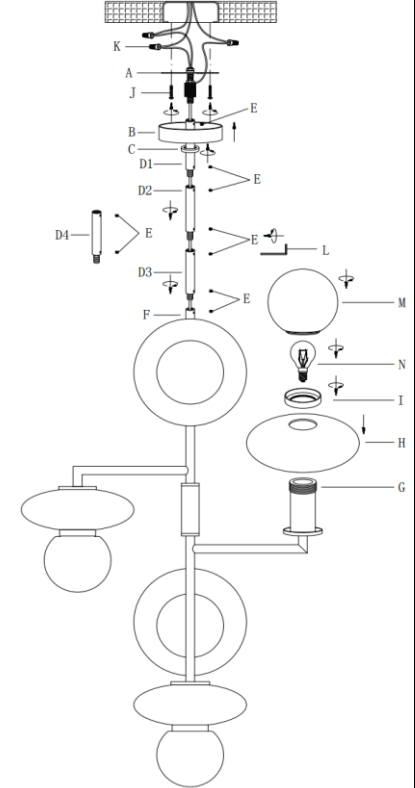

ASSEMBLY INSTRUCTIONS

1. REMOVE ALL PACKING CONTENTS AND PARTS FROM THE CARTON(S) CAREFULLY.
2. PLEASE BE SURE YOU HAVE ALL PARTS INDICATED BEFORE YOU BEGIN ASSEMBLY.
3. SHUT OFF THE MAIN ELECTRICAL SUPPLY FROM THE MAIN FUSE BOX/CIRCUIT BREAKER.
4. CONNECT LAMP BODY(F) AND CANOPY(B) WITH ROD(D1, D2, D3, D4), WHEN YOU CONNECT THE RODS, LOOSEN THE SMALL HEX SCREWS(E) FIRST THEN TIGHTEN WITH ALLEN WRENCH(L) AFTER ALL RODS ARE CONNECTED. BE SURE ALL THE HEX SCREWS(E) ARE TIGHT ENOUGH.
NOTE: IF YOU WANT THE FIXTURE TO BE SEMI-FLUSH MOUNT, YOU ONLY NEED CONNECT LAMP BODY(F) AND CANOPY(B) WITH ROD(D4).
5. CAREFULLY INSPECT THE FIXTURE WIRES. THE NEUTRAL FIXTURE WIRE HAS VERY FINE RIDGES MOLDED INTO ITS PLASTIC COVERING. THE HOT FIXTURE WIRE HAS A SMOOTH COVERING. THE BARE WIRE IS THE GROUNDED WIRE.
6. ATTACH THE GROUND WIRE FROM THE FIXTURE TO THE GROUND JUNCTION BOX WIRE FROM THE OUTLET (USUALLY GREEN OR BARE WIRE). FASTEN EACH TOGETHER WITH A PLASTIC WIRE CONNECTOR (K) AND WRAP THE CONNECTION WITH ELECTRICAL TAPE. IF YOUR OUTLET BOX DOES NOT HAVE A GROUND WIRE, INSERT THE GREEN GROUND SCREW INTO THE MOUNTING PLATE (A) FACING DOWN, AND WRAP THE FIXTURE'S BARE GROUND WIRE AROUND THE GROUND SCREW.
IT IS IMPERATIVE THAT THE OUTLET BOX IN YOUR HOME BE PROPERLY GROUNDED.
7. CONNECT THE NEUTRAL FIXTURE WIRE TO THE NEUTRAL JUNCTION BOX WIRE (USUALLY WHITE). FASTEN EACH TOGETHER WITH A WIRE CONNECTOR (K) AND WRAP THE CONNECTION WITH ELECTRICAL TAPE. BE SURE NO STRANDS ARE EXPOSED.
8. CONNECT THE HOT FIXTURE WIRE TO THE HOT JUNCTION BOX WIRE (USUALLY BLACK). FASTEN EACH TOGETHER WITH A PLASTIC WIRE CONNECTOR (K) AND WRAP THE CONNECTION WITH ELECTRICAL TAPE. BE SURE NO WIRE STRANDS ARE EXPOSED. **DO NOT REVERSE THE HOT AND NEUTRAL CONNECTIONS OR SAFETY WILL BE COMPROMISED.**
9. GENTLY TUCK THE WIRE CONNECTIONS NEATLY INTO THE JUNCTION BOX.
10. ATTACH THE MOUNTING PLATE (A) TO THE OUTLET BOX BY USING THE MOUNTING SCREWS(J) AND TIGHTEN SCREWS WITH A SCREWDRIVER.
11. PUSH COLLAR LOOP(C) IN CANOPY (B) AND TIGHTEN ONTO NIPPLE IN MOUNTING PLATE (A) BY TURNING IN A CLOCKWISE DIRECTION.
12. ATTACH THE OVAL GLASS SHADE(H) TO SOCKET(G) AND FIX IT WITH DECORATIVE RING(I) IN A CLOCKWISE DIRECTION, THEN INSTALL THE BULB(N) IN A CLOCKWISE DIRECTION AS WELL. LASTLY, ATTACH THE ROUND GLASS SHADE(M) TO THE SOCKET(G) IN A CLOCKWISE DIRECTION.
13. THEN ASSEMBLE OTHER GLASS SHADE IN TURN.
14. RESTORE POWER TO THE JUNCTION BOX AND TEST FIXTURE.
15. **FOR NON-USER REPLACEABLE LIGHT SOURCES: THE LIGHT SOURCE CONTAINED IN THIS LUMINAIRE SHALL ONLY BE REPLACE BY THE MANUFACTURER OR HIS SERVICE AGENT OR A SIMILAR QUALIFIED PERSON.**

CLEANING INSTRUCTIONS:

TO CLEAN, USE SOFT CLOTH ONLY. DO NOT USE ANY CHEMICAL OR ABRASIVE CLEANERS.

CARE & MAINTENANCE

DUST WITH A DRY CLOTH.

FOR CUSTOMER SERVICE QUESTIONS CALL 1.888.488.8866
 ARTERIORS HOME: 972.488.9800
 ARTERIORS CONTRACT: 972.488.9800 EXT.321

DISCLAIMERS

WE RECOMMEND THE INSTALLATION OF THIS ELECTRICAL LIGHT FIXTURE TO BE DONE BY A LICENSED ELECTRICIAN.

ARTERIORS