

ASSEMBLY INSTRUCTIONS

ITEM #89649 | Linear Chandelier

ITEM DESCRIPTION

MATERIAL TYPE: STEEL LINEN-COTTON FINISH :AMERICAN BRONZE WHITE
 SOCKET TYPE: E12 CERAMIC SOCKET QTY:7 TOP COAT/SEALANT:
 BULB TYPE: TYPE B BULB WATTAGE: 60W or/CFL 16W or/LED 13W
 ITEM NET WEIGHT: TOP COAT/SEALANT:

UL COMPLAINT

INSTALLATION ENVIRONMENT: SUITABLE FOR DAMP LOCATIONS



NOTE:

- *YOUR PRODUCT(S) MAY BE PACKED IN MORE THAN ONE CARTON
- *THIS ITEM MAY REQUIRE PERIODIC TIGHTENING

PARTS

A	MOUNTING PLATE	1 PC
B	SCREW NUT	2 PCS
C	CANOPY	1 PC
D	RODS	8 PCS
E	COLUMN	1 PC
F	PIPE	2 PCS
G	SOCKET ASSEMBLY	1 PC
H	SET SCREW	4 PCS
I	SHADE	1 PC
J	FRAME	2 PCS
K	CANOPY SCREW	6 PCS

INCLUDED ASSEMBLY HARDWARE

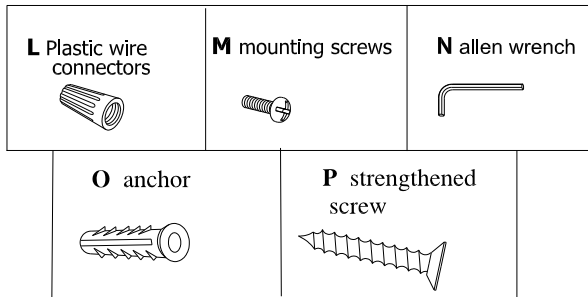

PRODUCT ASSEMBLY

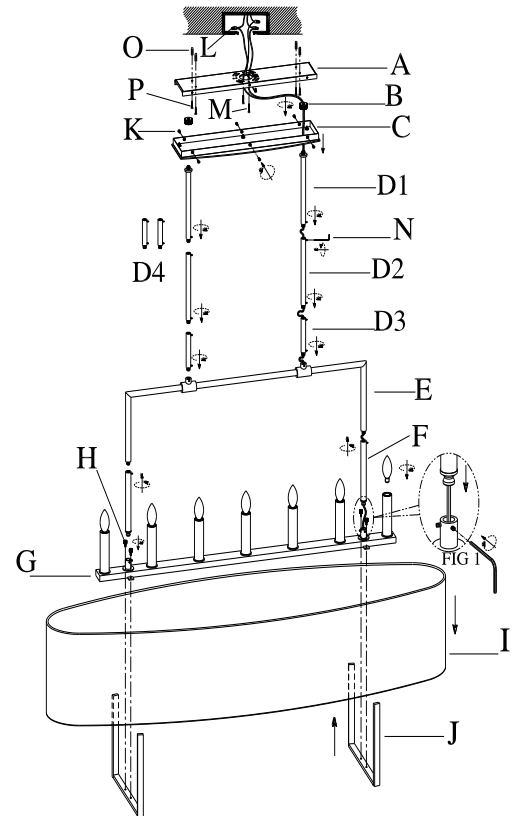

ASSEMBLY INSTRUCTIONS

1. REMOVE ALL PACKING CONTENTS FROM THE CARTON(S) CAREFULLY
2. REMOVE ALL PARTS FROM THE PACKAGE(S) CAREFULLY
3. PLEASE BE SURE YOU HAVE ALL PARTS INDICATED BEFORE YOU BEGIN ASSEMBLY
4. SHUT OFF THE MAIN ELECTRICAL SUPPLY FROM THE MAIN FUSE BOX/CIRCUIT BREAKER
5. REMOVE THE MOUNTING PLATE(A) FROM THE CANOPY(C) BY LOOSING 6PCS CANOPY SCREWS(K).
6. SCREW THE ROD(D3) ONTO THE COLUMN(E), AND TIGHTEN THE HEXANGULAR SCREW IN THE SIDE DESIRE HOLE BY ALLEN WRENCH(N). REPEAT THE SAME OPERATION ON THE ROD (D1) AND (D2). AND IF THE CEILING IS HIGH ENOUGH, PLS ASSEMBLE THE ROD(D4) IF NEED.
7. SCREW THE PIPE(F) ONTO THE COLUMN(E), AND AS SHOWN IF FIG1, INSERT ANOTHER END INTO THE TOP RING ON SOCKET ASSEMBLY(G) THEN USE 2PCS HEXANGULAR SCREWS BY ALLEN WRENCH(N) TILL TIGHT.
8. PASS THE ROD(D1) THROUGH CANOPY(C) AND TIGHTEN IT BY USING SCREW NUT(B), PASS THROUGH THE CORD AS DRAWING SHOWN. REPEAT THE ABOVER OPERATIONS(6) AND (7) ON ANOTHER SIDE.
9. ATTACH THE SHADE(I) TO THE SOCKET ASSEMBLY(G), AND THREAD 2PCS SET SCREWS ON FRAME(J) EACH TILL TIGHT.
10. CAREFULLY INSPECT THE PENDANT'S FIXTURE WIRE. THE NEUTRAL FIXTURE WIRE HAS VERY FINE RIDEGS MOLDED INTO ITS PLASTIC COVERING. THE HOT FIXTURE WIRE HAS A SMOOTH COVERING. THE BARE SILVER WIRE IS THE GROUNDED WIRE.
11. ATTACH THE GROUND WIRE FROM THE FIXTURE TO THE GROUND JUNCTION BOX WIRE FROM THE OUTLET (USUALLY GREEN) OR BARE WIRE). FASTEN EACH TOGETHER WITH A PLASTIC WIRE CONNECTOR (L) AND WRAP THE CONNECTION WITH ELECTRICAL TAPE. IF YOUR OUTLET BOX DOES NOT HAVE A GROUND WIRE, INSERT THE GREEN GROUND SCREW INTO THE MOUNTING PLATE (A) FACING DOWN, AND WRAP THE FIXTURE'S BARE GROUND WIRE AROUND THE GROUND SCREW. IT IS IMPERATIVE THAT THE OUTLET BOX IN YOUR HOME BE PROPERLY GROUNDED.
12. CONNECT THE NEUTRAL FIXTURE WIRE TO THE NEUTRAL JUNCTION BOX WIRE (USUALLY WHITE). FASTEN EACH TOGETHER WITH A WIRE CONNECTOR (L) AND WRAP THE CONNECTION WITH ELECTRICAL TAPE. BE SURE NO STRANDS ARE EXPOSED.
13. CONNECT THE HOT FIXTURE WIRE TO THE HOT JUNCTION BOX WIRE (USUALLY BLACK). FASTEN EACH TOGETHER WITH A PLASTIC WIRE CONNECTOR (L) AND WRAP THE CONNECTION WITH ELECTRICAL TAPE. BE SURE NO WIRE STRANDS ARE EXPOSED. DO NOT REVERSE THE HOT AND NEUTRAL CONNECTIONS OR SAFETY WILL BE COMPROMISED.
14. GENTLY TRUCK THE WIRE CONNECTIONS NEATLY INTO THE CEILING JUNCTION BOX.
15. ATTACH THE MOUNTING PLATE (A) WITH NIPPLE TO THE CEILING OUTLET BOX USING THE ENCLOSED MOUNTING SCREWS (M) AND TIGHTEN SCREWS WITH A SCREWDRIVER.
16. IF ATTACH TO CEMENT CEILING, USE ANCHOR(O) FIRST THEN SCREW STRENGTHENED SCREWS(P) INTO THE ANCHOR.
17. IF ATTACH TO WOOD CEILING, THREAD STRENGTHENED SCREW(P) DIRECTLY INTO CEILING
18. PUSH MOUNTING PLATE(A) IN CANOPY (B) AND THREAD THE CANOPY SCREWS(K) TO SECURE IT TILL TIGHT.
19. INSERT 7 TYPE B 60W BULBS(OR SUITABLE CFL 16W/LED 13W BULBS ,NOT INCLUDED) IN THE SOCKETS. **DO NOT EXCEED SPECIFIED WATTAGE.**

CARE & MAINTENANCE

FOR CUSTOMER SERVICE QUESTION CALL 1-800-338-2150

DISCLAIMERS

ARTERIOS HOME: 972.488.9800

WE RECOMMEND THE INSTALLATION OF THIS ELECTRICAL LIGHT FIXTURE TO BE DONE BY A LICENSED ELECTRICIAN.

ARTERIOS CONTRACT: 972.488.9800 EXT.321

ARTERIOS