

# ASSEMBLY INSTRUCTIONS

## ITEM DESCRIPTION

MATERIAL TYPE: METAL+ ACRYLIC FINISH: EBN/WHITE ACRYLIC DIFFUSER  
SOCKET TYPE:LED SOCKET QTY:  
BULB TYPE: BULB WATTAGE: LED 9W VOLTAGE:100V-120V  
ITEM NET WEIGHT:  
UL COMPLIANT  
INSTALLATION ENVIRONMENT:SUITABLE FOR DRY LOCATIONS

NOTE:  
\*YOUR PRODUCT(S) MAY BE PACKED IN MORE THAN ONE CARTON  
\*THIS ITEM MAY REQUIRE PERIODIC TIGHTENING  
\*MIN 75°C SUPPLY CONDUCTORS

## PARTS

A	LAMP BODY	1 PC
B	LAMP BASE	1 PC
C	SET SCREW	1 PS

## TOOLS NEEDED(INCLUDED)

D Allen wrench



## ASSEMBLY INSTRUCTIONS

- 1..REMOVE ALL PACKING CONTENTS AND PARTS FROM THE CARTON(S)C
- 2.PLEASE BE SURE YOU HAVE ALL PARTS INDICATED BEFORE YOU BEGIN
3. ATTACH THE SET SCREW (C) ONTO THE LAMP BASE (B) WITH ALLEN W
- 4.THE DIRECTION OF THE LAMPSHADE CAN BE ADJUSTED LEFT AND RIGH
- 5.TURN THE SWITCH (F) CLOCKWISE OR COUNTERCLOCKWISE TO ADJU

**CARE & MAINTENANCE**

DUST WITH A DRY CLOTH.

FOR CUSTOMER SERVICE QUESTIONS CALL 1.888.488.8866

ARTERIOS HOME:972.488.9800

ARTERIOS CONTRACT:972.488.9800 EXT.321

**DISCLAIM**

**WE RECOMM**

ARTERIOS

ITEM # 49541 / TABLE LAMP

TOP COAT/SEALANT

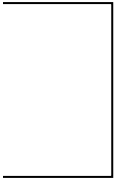

PRODUCT ASSEMBLY

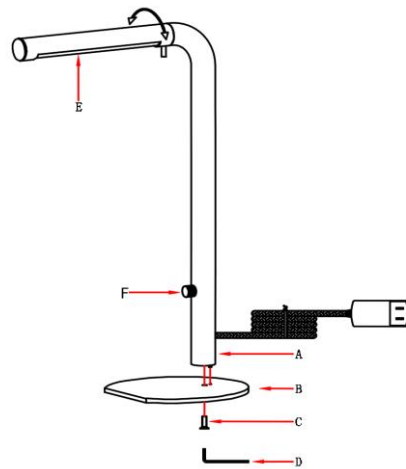

BE CAREFUL.

BE CAREFUL DURING ASSEMBLY.

USE THE SCREWDRIVER (D), AND TIGHTEN IT WITH A SCREWDRIVER.

BE CAREFUL

ADJUST THE BRIGHTNESS OF THE LIGHT SOURCE.

**IERS**

END THE INSTALLATION OF THIS ELECTRICAL LIGHT FIXTURE TO BE DONE BY A LICENSED ELECTRICIAN.

