

# ASSEMBLY INSTRUCTIONS

ITEM # 49540 / TABLE LAMP

## ITEM DESCRIPTION

MATERIAL TYPE:METAL+ ACRYLIC FINISH :ANTIQUE BRASS/WHITE ACRYLIC DIFFUSER TOP COAT/SEALANT  
SOCKET TYPE:LED SOCKET QTY:  
BULB TYPE: BULB WATTAGE: LED 9W VOLTAGE:100V-120V  
ITEM NET WEIGHT:  
UL COMPLIANT  
INSTALLATION ENVIRONMENT:SUITABLE FOR DRY LOCATIONS



NOTE:  
\*YOUR PRODUCT(S) MAY BE PACKED IN MORE THAN ONE CARTON  
\*THIS ITEM MAY REQUIRE PERIODIC TIGHTENING  
\*MIN 75°C SUPPLY CONDUCTORS

## PARTS

A	LAMP BODY	1 PC
B	LAMP BASE	1 PC
C	SET SCREW	1 PS

## TOOLS NEEDED(INCLUDED)

D Allen wrench



## PRODUCT ASSEMBLY

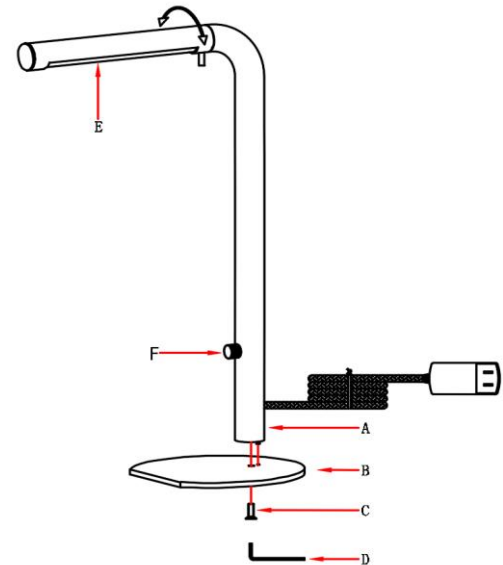

## ASSEMBLY INSTRUCTIONS

- 1..REMOVE ALL PACKING CONTENTS AND PARTS FROM THE CARTON(S)CAREFULLY.
- 2.PLEASE BE SURE YOU HAVE ALL PARTS INDICATED BEFORE YOU BEGIN ASSEMBLY.
3. ATTACH THE SET SCREW (C) ONTO THE LAMP BASE (B) WITH ALLEN WRENCH (D), AND TIGHTEN IT WITH A SCREWDRIVER.
- 4.THE DIRECTION OF THE LAMPSHADE CAN BE ADJUSTED LEFT AND RIGHT
- 5.TURN THE SWITCH (F) CLOCKWISE OR COUNTERCLOCKWISE TO ADJUST THE BRIGHTNESS OF THE LIGHT SOURCE.

## CARE & MAINTENANCE

DUST WITH A DRY CLOTH.

FOR CUSTOMER SERVICE QUESTIONS CALL 1.888.488.8866

ARTERIOS HOME:972.488.9800

ARTERIOS CONTRACT:972.488.9800 EXT.321

## DISCLAIMERS

WE RECOMMEND THE INSTALLATION OF THIS ELECTRICAL LIGHT FIXTURE TO BE DONE BY A LICENSED ELECTRICIAN

ARTERIOS