

# ASSEMBLY INSTRUCTIONS

ITEM # 49524 | EBN and Alabaster Wall Sconce

## ITEM DESCRIPTION

MATERIAL TYPE: STEEL /ALABASTER FINISH :EBN + ALABASTER TOP COAT/SEALANT:  
 SOCKET TYPE: E12 CERAMIC SOCKET QTY: 2  
 BULB TYPE: TYPE T BULB WATTAGE: **MAX 8W LED BULB ONLY** VOLTAGE:110V-120V  
 ITEM NET WEIGHT:  
 UL COMPLIANT  
 INSTALLATION ENVIRONMENT:SUITABLE FOR DAMP LOCATIONS





NOTE:  
 \*YOUR PRODUCT(S) MAY BE PACKED IN MORE THAN ONE CARTON  
 \*THIS ITEM MAY REQUIRE PERIODIC TIGHTENING

## PARTS

<b>A</b>	<b>MOUNTING PLATE</b>	<b>1 PC</b>
<b>B</b>	<b>BACK PLATE SCREW</b>	<b>2 PCS</b>
<b>C</b>	<b>LAMP BODY</b>	<b>1 PC</b>
<b>D</b>	<b>ALABASTER SHADE</b>	<b>1 PC</b>
<b>E</b>	<b>SOCKETS</b>	<b>2 PCS</b>
<b>F</b>	<b>BULB(NOT INCLUDED)</b>	<b>2 PCS</b>
<b>H</b>	<b>SET SCREWS</b>	<b>2 PCS</b>
<b>I</b>	<b>ANCHOR</b>	<b>3 PCS</b>
<b>L</b>	<b>STRENGTHENED SCREW</b>	<b>3 PCS</b>

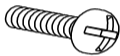
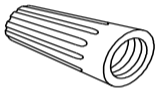
## INCLUDED ASSEMBLY HARDWARE

<b>J</b> mounting screws 	<b>K</b> Plastic wire connectors 
<b>I</b> anchor 	<b>L</b> strengthened screw 

## PRODUCT ASSEMBLY

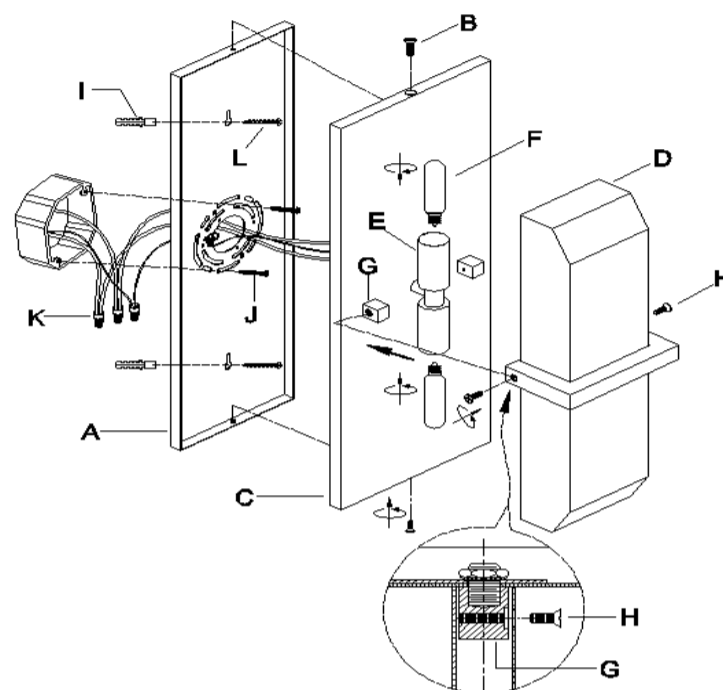

## ASSEMBLY INSTRUCTIONS

- 1.REMOVE ALL PACKING CONTENTS AND PARTS FROM THE CARTON(S)CAREFULLY
- 2.PLEASE BE SURE YOU HAVE ALL PARTS INDICATED BEFORE YOU BEGIN ASSEMBLY
- 3.SHUT OFF THE MAIN ELECTRICAL SUPPLY FROM THE MAIN FUSE BOX/CIRCUIT BREAKER.
- 4.REMOVE THE MOUNTING PLATE (A) FROM THE LAMP BODY(C) BY TURNING BACK PLATE SCREWS(B ) IN A ANTICLOCKWISE DIRECTION.
- 5.PULL THE ELECTRICAL CORD OF "J BOX"THROUGH THE EXIT HOLE OF THE MOUNTING PLATE(A)
- 6.CAREFULLY INSPECT THE FIXTURE WIRES. THE NEUTRAL FIXTURE WIRE HAS VERY FINE RIDEGS MOLDED INTO ITS PLASTIC COVERING. THE HOT FIXTURE WIRE HAS A SMOOTH COVERING.THE BARE WIRE IS THE GROUNDED WIRE.
7. ATTACH THE GROUND WIRE FROM THE FIXTURE TO THE GROUND JUNCTION BOX WIRE FROM THE OUTLET (USUALLY GREEN OR BARE WIRE). FASTEN EACH TOGETHER WITH A PLASTIC WIRE CONNECTOR (K) AND WRAP THE CONNECTION WITH ELECTRICAL TAPE. IF YOUR OUTLET BOX DOES NOT HAVE A GROUND WIRE, INSERT THE GREEN GROUND SCREW INTO THE MOUNTING PLATE (A) FACING DOWN, AND WRAP THE FIXTURE'S BARE GROUND WIRE AROUND THE GROUND SCREW.  
**IT IS IMPERATIVE THAT THE OUTLET BOX IN YOUR HOME BE PROPERLY GROUNDED.**
8. CONNECT THE NEUTRAL FIXTURE WIRE TO THE NEUTRAL JUNCTION BOX WIRE (USUALLY WHITE). FASTEN EACH TOGETHER WITH A WIRE CONNECTOR (K) AND WRAP THE CONNECTION WITH ELECTRICAL TAPE. BE SURE NO STRANDS ARE EXPOSED.
- 9.CONNECT THE HOT FIXTURE WIRE TO THE HOT JUNCTION BOX WIRE (USUALLY BLACK). FASTEN EACH TOGETHER WITH A PLASTIC WIRE CONNECTOR (K) AND WRAP THE CONNECTION WITH ELECTRICAL TAPE. BE SURE NO WIRE STRANDS ARE EXPOSED. **DO NOT REVERSE THE HOT AND NEUTRAL CONNECTIONS OR SAFETY WILL BE COMPROMISED.**
10. GENTLY TUCK THE WIRE CONNECTIONS NEATLY INTO THE JUNCTION BOX.
- 11.**DRILL 2 HOLES IN WALL IN LINE WITH 2 HOLES OF MOUNTING PLATE(A), ATTACH THE MOUNTING PLATE (A) TO THE OUTLET BOX USING THE MOUNTING SCREWS(J) AND TIGHTEN WITH A SCREWDRIVER.THEN SCREW THE STRENGTHENED SCREWS (L) INTO THE ANCHORS TO SECURE THE MOUNTING PLATE(A).**  
**IF ATTACH TO CEMENT WALL, USE ANCHOR(L) FIRST THEN SCREW STRENGTHENED SCREWS(L)INTO THE ANCHOR**  
**IF ATTACH TO WOOD WALL,THREAD STRENGTHENED SCREW(L) DIRECTLY INTO WALL**
- 12.**ATTACH THE LAMP BODY(C) TO THE MOUNTING PLATE(A) BY USING THE ENCLOSED BACK PLATE SCREWS(B) AND TIGHTEN SCREWS(B) WITH SCREWDRIVER.**
- 13.INSERT 2 TYPE T MAX 8W LED BULBS (F) ONLY (NOT INCLUDED) INTO THE SOCKETS(E).**DO NOT EXCEED SPECIFIED WATTAGE.**
- 14.ATTACH ALABASTER SHADE (D) TO THE LAMP BODY(C), AND THEN TIGHTEN THE ALABASTER SHADE(D) BY 2 SET SCREWS (H) TO SECURE THE ALABASTER SHADE(D).
- 15.RESTORE POWER TO THE JUNCTION BOX AND TEST FIXTURE.

## CARE & MAINTENANCE

DUST WITH A DRY CLOTH.  
 FOR CUSTOMER SERVICE QUESTIONS CALL 1.888.488.8866  
 ARTERIORS HOME:972.488.9800  
 ARTERIORS CONTRACT:972.488.9800 EXT.321

## DISCLAIMERS

WE RECOMMEND THE INSTALLATION OF THIS ELECTRICAL LIGHT FIXTURE TO BE DONE BY A LICENSED ELECTRICIAN.

# ARTERIALS