

ARTERIOS

NAKOA BAR CART

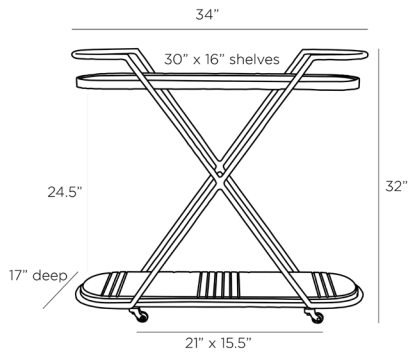

4650

H: 32 IN, W: 34 IN, D: 17 IN

Blackened Iron

Contract Recommendations: Adding a lacquer coating provides additional protection

Untempered glass

The Nakoa celebrates Art Deco design through rich texture and elegant form. A blackened iron foundation presents a minimalist profile with x-shaped legs that rest on an attached black marble base that doubles as a shelf. The marble features a chiseled deco pattern for a look that emphasizes the machine-age and sleek geometric aesthetic, further playing up its architectural inspiration. A clear glass top makes this bar cart functional, and the raised handles allow easy mobility. Marble will

APPEARANCE

Material	Glass, Iron, Marble
Material Type	Etched
Finish	Black, Blackened Iron, Clear
Finish Will Vary	true
Top Coat/Sealant	true
Fixed Shelf Count	1

DIMENSIONS

Foot Print	16
Shelf	W: 21 IN, D: 15.5 IN
Clearance	W: 30 IN, D: 16 IN
Diagonal Dimension	2"
Shelf Clearance	36.5" IN
	24.5"

SHIPPING

Shipping Requirements	TruckShip
Product Weight	84.88 LBS
Gross Weight 1	101.41 LBS
Shipping Box 1	H: 36.5 IN, L: 35 IN, W: 19 IN

ADDITIONAL INFO

Leg Or Foot Application Caster Wheel

CONTRACT

Contract Suitable Adding a lacquer coating provides additional protection, Untempered glass